

***TM 55-1925-284-14&P**

TECHNICAL MANUAL

**OPERATOR, UNIT, DIRECT SUPPORT, AND GENERAL
SUPPORT MAINTENANCE MANUAL INCLUDING
REPAIR PARTS AND SPECIAL TOOLS LIST
FOR
MARINE SANITATION DEVICE**

**INLAND AND COASTAL LARGE TUG (LT)
NSN 1925-01-509-7013 (EIC XAG)**

*Supersedes TM 55-1925-219-24&P, 16 August 1991.

DISTRIBUTION STATEMENT A: Approved for public release; distribution is unlimited.

HEADQUARTERS, DEPARTMENT OF THE ARMY

NOVEMBER 2005

WARNING SUMMARY

FIRST AID

Although the 128' Large Tug is normally assigned a medic, first aid is still an important skill for all crewmembers. The ability to promptly administer first aid to another crewmember could mean the difference between life and death for that crewmember. First aid procedures for soldiers are contained in FM 4-25.11.

WARNING SUMMARY CONTENT

This warning summary contains general safety warnings and hazardous materials warnings that must be understood and applied during operation and maintenance of this vessel and its equipment. Failure to observe these precautions could result in serious injury or death to personnel. Also included are explanations of safety and of hazardous materials used within the technical manual.

CHLORINE

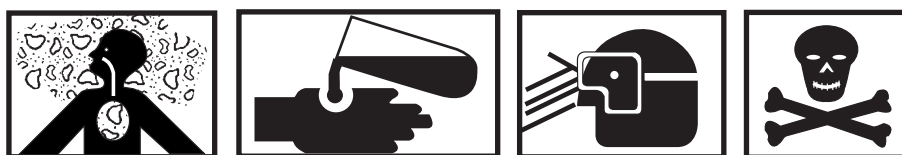

Chlorine tablets can be hazardous. Do not inhale vapors or tablet dust. Protect eyes and skin from contact with tablets. Handle tablets with rubber gloves and a safety shield or goggles. Wash thoroughly with water after contact. Keep away from oil, rags, paper, and other combustible materials. Store in a cool dry area. In case of fire, use water.

OILS/CLEANING SOLVENTS



Do not allow hydraulic fluid, engine oil, or cleaning solvents to come in contact with unprotected skin or eyes. Prolonged skin contact can cause illness or injury. Eye contact can cause serious injury. Always wear chemical protective gloves and goggles when handling hydraulic fluid, engine oil, and cleaning solvents. Failure to follow these precautions can result in illness or serious injury.



Cleaning solvent is flammable and its vapor is potentially explosive. Do not use cleaning solvent in the vicinity of spark, open flame, or excessive heat. Do not use cleaning solvent in unventilated spaces. Failure to follow these precautions can result in death or serious injury.

SEWAGE



Sewage is a common mode of transmission for parasitic organisms that may have the capability of causing communicable diseases. Protective gloves and a protective apron should be worn to help prevent contact with sewage. After coming in contact with sewage or contaminated equipment, be sure to clean yourself with a disinfectant soap. Avoid sewage contact with skin abrasions, punctures, cuts, and other open wounds. Wipe up and clean any spills and/or contaminated equipment using a disinfectant soap.



Personnel shall not enter or open the media tank or sewage piping at any time unless it is done at a suitable industrial facility or it has been certified gas free by qualified gas free personnel. Adequate ventilation shall be provided in the space and verified and approved by the gas free personnel before proceeding.



Toxic and flammable vapors are generated in the sewage system. Provide ventilation from outside source. Avoid open flames and prolonged breathing of fumes.

ELECTRICAL



Take great care when working around energized electrical equipment. Contact between unprotected body parts and electrical conductors can cause serious injury or death. Do not wear jewelry or other conductive items while servicing energized electrical equipment. Failure to comply with these precautions can cause serious injury or death.

Replace or repair components only after the affected circuit has been secured, locked out, and tagged out. Performing replacement with the circuit energized may result in injury.

LOCKING HARDWARE

Never reuse locking hardware. Reuse of locking hardware such as lock washers, locking nuts, cotter pins, and lockwire can result in undetected loosening of fastening hardware causing catastrophic component failure resulting in death, injury, or damage to equipment. In accordance with TB 43-0218, ensure that all locking hardware is discarded upon removal and replaced with new.

EXPLANATION OF SAFETY WARNING ICONS



BIOLOGICAL - abstract symbol bug shows that a material may contain bacteria or viruses that present a danger to life or health.



CHEMICAL - drops of liquid on hand show that the material will cause burns or irritation to human skin or tissue.

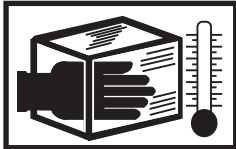

CRYOGENIC - hand in block of ice shows that the material is extremely cold and can injure human skin or tissue.



EAR PROTECTION - headphones over ears show that noise level will harm ears.



ELECTRICAL - electrical wire to arm with electricity symbol running through human body shows that shock hazard is present.



ELECTRICAL - electrical wire to hand with electricity symbol running through hand shows that shock hazard is present.



EXPLOSION - rapidly expanding symbol shows that the material may explode if subjected to high temperatures, sources of ignition, or high pressure.

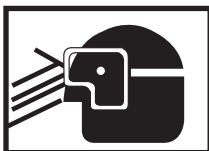

EYE PROTECTION - person with goggles shows that the material will injure the eyes.



FALLING PARTS - arrow bouncing off human shoulder and head shows that falling parts present a danger to life or limb.

EXPLANATION OF SAFETY WARNING ICONS (continued)



FIRE - flame shows that a material may ignite and cause burns.



FLYING PARTICLES - arrows bouncing off face show that particles flying through the air will harm face.

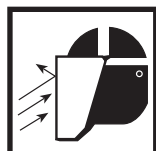

FLYING PARTICLES - arrows bouncing off face with face shield show that particles flying through the air will harm face.



HEAVY OBJECT - human figure stooping over heavy object shows physical injury potential from improper lifting technique.



HEAVY PARTS - hand with heavy object on top shows that heavy parts can crush and harm.



HEAVY PARTS - foot with heavy object on top shows that heavy parts can crush and harm.



HEAVY PARTS - heavy object on human figure shows that heavy parts present a danger to life or limb.



HEAVY PARTS - heavy object pinning human figure against wall shows that heavy, moving parts present a danger to life or limb.



HELMET PROTECTION - arrow bouncing off head with helmet shows that falling parts present a danger.

EXPLANATION OF SAFETY WARNING ICONS (continued)



HOT AREA - hand over object radiating heat shows that part is hot and can burn.



LASER LIGHT - laser light hazard symbol indicates extreme danger for eyes from laser beams and reflections.



MOVING PARTS - human figure with an arm caught between gears shows that the moving parts of the equipment present a danger to life or limb.



MOVING PARTS - hand with fingers caught between gears shows that the moving parts of the equipment present a danger to life or limb.



MOVING PARTS - hand with fingers caught between rollers shows that the moving parts of the equipment present a danger to life or limb.



SHARP OBJECT - pointed object in hand shows that a sharp object presents a danger to limb.



SHARP OBJECT - pointed object in hand shows that a sharp object presents a danger to limb.



SHARP OBJECT - pointed object in foot shows that a sharp object presents a danger to limb.



SLICK FLOOR - wavy line on floor with legs prone shows that slick floor presents a danger for falling

EXPLANATION OF SAFETY WARNING ICONS (continued)



POISON - skull and crossbones show that a material is poisonous or is a danger to life.



RADIATION - three circular wedges show that the material emits radioactive energy and can injure human tissue.



VAPOR - human figure in a cloud shows that material vapors present a danger to life or health.

CHANGE

NO. 1

HEADQUARTERS
DEPARTMENT OF THE ARMY
WASHINGTON, D.C., 30 JULY 2008

TECHNICAL MANUAL
OPERATOR, UNIT, DIRECT SUPPORT, AND
GENERAL SUPPORT MAINTENANCE MANUAL
INCLUDING
REPAIR PARTS AND SPECIAL TOOLS LIST
FOR
MARINE SANITATION DEVICE

INLAND AND COASTAL LARGE TUG (LT)
NSN 1925-01-509-7013 (EIC XAG)

Distribution Statement A: Approved for public release; distribution is unlimited.

TM 55-1925-284-14&P, 30 November 2005, is changed as follows:

1. Remove and insert pages as indicated below. New or changed text is indicated by a vertical bar in the margin. An illustration change is indicated by a miniature pointing hand.

Remove pages

None

None

A/B blank

i through iv

0001 00-1 through 0001 00-4

0004 00-1 through 0004 00-8

0005 00-1 through 0005 00-10

0006 00-1 through 0006 00-6

0014 00-1 through 0014 00-12

0015 00-1 through 0015 00-2

0016 00-1 through 0016 00-8

0017 00-1 through 0017 00-6

0018 00-1 through 0018 00-2

0019 00-1 through 0019 00-4

0020 00-1 through 0020 00-4

0021 00-1 through 0021 00-4

0022 00-1 through 0022 00-4

0023 00-1 through 0023 00-6

0024 00-1 through 0024 00-4

0025 00-1 through 0025 00-6

0028 00-1 through 0028 00-10

0030 00-1 through 0030 00-4

0031 00-1 through 0031 00-6

0032 00-1 through 0032 00-4

DA Form 2028

Insert pages

Change Transmittal Sheet

Authentication Page

A/B blank

i through iv

0001 00-1 through 0001 00-4

0004 00-1 through 0004 00-8

0005 00-1 through 0005 00-10

0006 00-1 through 0006 00-4

0014 00-1 through 0014 00-12

0015 00-1 through 0015 00-2

0016 00-1 through 0016 00-8

0017 00-1 through 0017 00-6

0018 00-1 through 0018 00-2

0019 00-1 through 0019 00-4

0020 00-1 through 0020 00-4

0021 00-1 through 0021 00-4

0022 00-1 through 0022 00-4

0023 00-1 through 0023 00-6

0024 00-1 through 0024 00-4

0025 00-1 through 0025 00-6

0028 00-1 through 0028 00-10

0030 00-1 through 0030 00-4

0031 00-1 through 0031 00-6

0032 00-1 through 0032 00-4

DA Form 2028

2. Retain this sheet in front of the manual for reference purposes.

By Order of the Secretary of the Army:

Official:



JOYCE E. MORROW

*Administrative Assistant to the
Secretary of the Army*

0819116

GEORGE W. CASEY, JR.
*General, United States Army
Chief of Staff*

Distribution:

To be distributed in accordance with the initial distribution number (IDN) 255634,
requirements for TM 55-1925-184-14&P.

INSERT LATEST CHANGED PAGES. DESTROY SUPERSEDED DATA.

LIST OF EFFECTIVE PAGES/WORK PACKAGES

NOTE: The portion of text affected by the changes is indicated by a vertical line in the outer margins of the page. Changes to illustrations are indicated by miniature pointing hands. Changes to wiring diagrams are indicated by shaded areas.

Dates of original issue and changed pages for this manual are:

Original 30 November 2005

Change 1 30 July 2008

TOTAL NUMBER OF PAGES FOR FRONT AND REAR MATTER IS 30 AND TOTAL NUMBER OF WORK PACKAGES IS 39, CONSISTING OF THE FOLLOWING:

Page/WP No.	* Change No.	Page/WP No.	* Change No.
Front Cover.....	0	WP 0020 00 (4 pgs).....	1
a-f	0	WP 0021 00 (4 pgs).....	1
A	1	WP 0022 00 (4 pgs).....	1
B blank.....	1	WP 0023 00 (6 pgs).....	1
i - iv	1	WP 0024 00 (4 pgs).....	1
Chp 1 title page	0	WP 0025 00 (6 pgs).....	1
WP 0001 00 (4 pgs).....	1	WP 0026 00 (2 pgs).....	1
WP 0002 00 (4 pgs).....	0	Chp 7 title page	0
WP 0003 00 (2 pgs).....	0	WP 0027 00 (4 pgs).....	0
Chp 2 title page	0	WP 0028 00 (10 pgs).....	0
WP 0004 00 (8 pgs).....	1	WP 0029 00 (10 pgs).....	0
WP 0005 00 (10 pgs).....	1	WP 0030 00 (4 pgs).....	1
WP 0006 00 (4 pgs).....	1	WP 0031 00 (6 pgs).....	1
Chp 3 title page	0	Chp 8 title page	0
WP 0007 00 (4 pgs).....	0	WP 0032 00 (4 pgs).....	1
WP 0008 00 (2 pgs).....	0	Chp 9 title page	0
WP 0009 00 (10 pgs).....	0	WP 0033 00 (2 pgs).....	0
Chp 4 title page	0	WP 0034 00 (4 pgs).....	0
WP 0010 00 (2 pgs).....	0	WP 0035 00 (4 pgs).....	0
WP 0011 00 (4 pgs).....	0	WP 0036 00 (6 pgs).....	0
WP 0012 00 (2 pgs).....	0	WP 0037 00 (20 pgs).....	0
Chp 5 title page	0	WP 0038 00 (6 pgs).....	0
WP 0013 00 (2 pgs).....	0	WP 0039 00 (2 pgs).....	0
WP 0014 00 (12 pgs).....	1	Glossary-1	0
WP 0015 00 (2 pgs).....	1	Glossary-2 blank.....	0
WP 0016 00 (8 pgs).....	1	Index-1 - Index-6	0
WP 0017 00 (6 pgs).....	1	Electronic DA Form 2028.....	1
WP 0018 00 (2 pgs).....	1	DA 2028.....	0
WP 0019 00 (4 pgs).....	1	Authentication Page	0
Chp 6 title page	0	Rear Cover	0

* Zero in this column indicates an original page.

HEADQUARTERS,
DEPARTMENT OF THE ARMY
WASHINGTON, D.C., 30 NOVEMBER 2005

TECHNICAL MANUAL

OPERATOR, UNIT, DIRECT SUPPORT, AND GENERAL SUPPORT MAINTENANCE MANUAL
INCLUDING REPAIR PARTS AND SPECIAL TOOLS LIST
FOR
MARINE SANITATION DEVICE
INLAND AND COASTAL LARGE TUG (LT)
NSN 1925-01-507-7013 (EIC XAG)

REPORTING ERRORS AND RECOMMENDING IMPROVEMENTS

You can help improve this publication. If you find any errors, or if you would like to recommend any improvements to the procedures in this publication, please let us know. The preferred method is to submit your DA Form 2028 (Recommended Changes to Publications and Blank Forms) through the Internet, on the Army Electronic Product Support (AEPS) website. The Internet address is <https://aeprs.ria.army.mil>. The DA Form 2028 is located under the Public Applications section in the AEPS Public Home Page. Fill out the form and click on SUBMIT. Using this form on the AEPS will enable us to respond quicker to your comments and better manage the DA Form 2028 program. You may also mail, e-mail, or fax your comments or DA Form 2028 directly to the U.S. Army TACOM Life Cycle Management Command. The postal mail address is U.S. Army TACOM Life Cycle Management Command, ATTN: AMSTA-LC-LMPP / TECH PUBS, 1 Rock Island Arsenal, Rock Island, IL 61299-7630. The e-mail address is tacomlcmc.daform2028@us.army.mil. The fax number is DSN 793-0726 or Commercial (309) 782-0726.

DISTRIBUTION STATEMENT A: Approved for public release, distribution is unlimited.

TABLE OF CONTENTS

WP Sequence No.

WARNING SUMMARY

HOW TO USE THIS MANUAL

CHAPTER 1 - GENERAL INFORMATION, EQUIPMENT DESCRIPTION, AND
THEORY OF OPERATION

General Information	0001 00
Equipment Description and Data	0002 00
Theory of Operation	0003 00

CHAPTER 2 - OPERATOR INSTRUCTIONS

Description and Use of Operator Controls and Indicators	0004 00
Operation Under Usual Conditions	0005 00
Operation Under Unusual Conditions	0006 00

*Supersedes TM 55-1925-219-24&P, 16 August 1991

TABLE OF CONTENTS (continued)

WP Sequence No.

CHAPTER 3 -TROUBLESHOOTING PROCEDURES

 Troubleshooting Index 0007 00

 Operator Troubleshooting Procedures 0008 00

 Unit Troubleshooting Procedures 0009 00

CHAPTER 4 - MAINTENANCE INSTRUCTIONS

 Service Upon Receipt and Preparation for Storage 0010 00

 PMCS Introduction 0011 00

 Operator Preventive Maintenance Checks and Services (PMCS) Including
 Lubrication 0012 00

CHAPTER 5 - OPERATOR MAINTENANCE INSTRUCTIONS

 Marine Sanitation Device, Adjust 0013 00

 Marine Sanitation Device, Service 0014 00

 Controller, Repair 0015 00

 Blower Assembly, Adjust 0016 00

 Blower Assembly, Service 0017 00

 Blower Assembly, Repair 0018 00

 Wet Well, Repair 0019 00

CHAPTER 6 - UNIT MAINTENANCE INSTRUCTIONS

 Marine Sanitation Device, Repair 0020 00

 Blower Assembly, Blower; Replace 0021 00

 Blower Assembly, Blower; Repair 0022 00

 Blower Assembly, Motor; Replace 0023 00

 Chlorinator, Replace 0024 00

 Pump Assembly, Replace 0025 00

 Pump Assembly, Repair 0026 00

CHAPTER 7 - DIRECT SUPPORT MAINTENANCE INSTRUCTIONS

 Marine Sanitation Device, Repair 0027 00

 Controller, Repair 0028 00

 Blower Assembly, Blower; Repair 0029 00

 Wet Well, Repair 0030 00

 Wet Well, Replace 0031 00

CHAPTER 8 - GENERAL SUPPORT MAINTENANCE INSTRUCTIONS

 Marine Sanitation Device, Repair 0032 00

CHAPTER 9 - SUPPPORTING INFORMATION

 References 0033 00

 Maintenance Allocation Chart (MAC) Introduction 0034 00

 Maintenance Allocation Chart 0035 00

 Repair Parts and Special Tools List Introduction 0036 00

 Repair Parts and Special Tools List 0037 00

 Components of End Item (COEI) and Basic Issue Items (BII) Lists 0038 00

 Expendable and Durable Items List 0039 00

GLOSSARY

ALPHABETICAL INDEX

HOW TO USE THIS MANUAL

USING THIS MANUAL

When using this manual, read and understand the entire maintenance action before performing the task. Also, read and understand all warnings, cautions, and notes as well as general safety precautions that apply to the task to be performed. The warning summary will inform personnel of hazards associated with the equipment to be worked on. However, the summary is not all inclusive and personnel should be aware at all times of hazardous conditions that may arise.

ACCESSING INFORMATION

Information is accessed by referring to the table of contents, located in the front of this manual, or by looking in the alphabetical index, located in the back of this manual.

To locate information using the table of contents, first scan the chapter titles to determine the general area in which your information will be contained. After locating the proper chapter, look beneath the chapter title to find the desired informational or procedural work package title. To the right of the work package title is a work package sequence number. This work package sequence number will direct you to the proper work package. Work packages are arranged in numerical order in this manual.

To locate information using the alphabetical index, look down the subject column on the left side of the page until you find the desired subject. To the right of the subject is the work package sequence number and page number. Go to the indicated work package and indicated page number to find the desired information.

INITIAL SETUP

Initial setup requirements are located directly above many of the procedures in this manual. The information is given to ensure all materials, expendables, tools and any other equipment necessary are readily available for use. The initial setup will be accomplished prior to starting the actual steps of each maintenance procedure. There are five basic headings listed under the initial setup:

Tools and Special Tools: This section lists all tools (standard or special) required to perform the task. Tools are identified with an item number and work package number from table 2 of the Maintenance Allocation Chart (MAC).

Materials/Parts: This section lists all of the materials and parts required to perform the task. If the material or part is needed each time the work package is used, then it is listed here. If the part is optional, replaced on a conditional basis, or is only needed for certain specific procedures within the work package it is not listed.

Personnel Required: This section lists all personnel necessary to perform the task. When a specific MOS or other personnel qualification is required, this MOS or additional requirement is also indicated.

Equipment Condition: This section notes the conditions that must exist before starting the task. The equipment condition will also include any prerequisite maintenance tasks to be performed with reference to the work package number or to the TM number that contains the required maintenance task.

References: This section lists any other publications necessary to complete the task. When there are no references listed, all steps necessary to complete the task are contained within this manual. A listing of reference materials is contained in the Supporting Information chapter at the rear of this manual.

ILLUSTRATIONS

Various visual methods are used to locate and repair components. Locator illustrations in Controls and Indicator tables, Preventive Maintenance Checks and Services (PMCS) tables, exploded views, and cut-away diagrams make the information in the manual easier to understand and follow.

LOCATING MAJOR COMPONENTS

This work package gives a brief description of the major components, and provides illustrations showing the location of the components. Knowing the major components of the system is the first step to understanding system operation and maintenance.

THEORY OF OPERATION

This work package contains the theory of operation for the system. Theory of operation is provided to familiarize the user system operating principles. Once the operating principles are understood, the user is better equipped to operate, troubleshoot, and maintain the system.

DESCRIPTION AND USE OF OPERATOR CONTROLS AND INDICATORS

This work package describes all of the operator controls and indicators contained in the system. Use of the operator controls and indicators is also described. Turn to the figure that shows the desired control or indicator. Note the key number corresponding to the control or indicator. Refer to the table below the illustration and find the desired key number in the column on the far left hand side. The center column contains the name of the control or indicator and the right hand column briefly describes the control or indicator's function.

OPERATOR INSTRUCTIONS

Work packages are included in this manual to describe operation under usual conditions as well as operation under unusual conditions. Prior to performing any operating procedure, perform the initial setup by obtaining the expendables, tools, materials and other items listed prior to starting the task. Always perform the listed steps in the listed order.

TROUBLESHOOTING PROCEDURES

A troubleshooting index work package is contained in this manual to permit easy location of troubleshooting procedures. Full directions for using the troubleshooting index and the accompanying troubleshooting procedures are contained in the troubleshooting index work packages. The troubleshooting procedure work package(s) immediately follow the troubleshooting index.

MAINTENANCE PROCEDURES

To locate a maintenance procedure, consult the table of contents or the alphabetical index. Each level of maintenance (operator, unit, direct support, and general support) has a chapter dedicated to maintenance procedures for the appropriate level of maintenance. Each maintenance work package contains complete maintenance procedures, starting with initial setup and continuing through follow on service as appropriate. Always ensure that all of the initial setup is complete before beginning a maintenance procedure and always ensure that all warnings, cautions, and notes are heeded.

MAINTENANCE ALLOCATION CHART

The MAC lists all of the authorized maintenance for the system assigns that maintenance to the appropriate maintenance level (operator, unit, direct support, general support). Use of the MAC is explained fully in the Maintenance Allocation Chart Introduction work package.

REPAIR PARTS AND SPECIAL TOOLS LIST (RPSTL)

The RPSTL lists all of the repair parts authorized for the system. Illustrations are provided to assist in locating the desired repair parts. Full instructions for use of the RPSTL are contained in the Repair Parts and Special Tools List Introduction work package. Always follow the directions contained in this work package when using the RPSTL.

ALPHABETICAL INDEX

The Alphabetical Index, located in the back of this manual, contains an alphabetical list of all sections of this manual. For example, Location and Description of Major Components is found in section L. The work package sequence number is found on the right side of the title where the Location and Description of Major Components is located. Turn to the work package indicated to find the description and location of each component.

Chapter 1

General Information, Equipment Description, and Theory of Operation for Marine Sanitation Device

Inland and Coastal Large Tug (LT)

**OPERATOR, UNIT, DIRECT SUPPORT, AND GENERAL SUPPORT MAINTENANCE
MARINE SANITATION DEVICE FOR
INLAND AND COASTAL LARGE TUG (LT)
GENERAL INFORMATION**

SCOPE

The information in this manual applies to all Inland and Coastal Large Tugs (LT) with the single tablet chlorinator. This manual contains operator instructions and maintenance procedures for the marine sanitation device used onboard these vessels.

MAINTENANCE FORMS, RECORDS, AND REPORTS

Department of the Army (DA) forms and procedures used for equipment maintenance will be those prescribed by DA PAM 738-750, Functional Users Manual for The Army Maintenance Management System (TAMMS).

REPORTING EQUIPMENT IMPROVEMENT RECOMMENDATIONS (EIR)

You can help improve this publication. If you find any mistakes or if you know of a way to improve the procedures, please let us know. Submit your DA Form 2028 (Recommended Changes to Equipment Technical Publications) through the Internet on the Army Electronic Product Support (AEPS) Website. The Internet address is <https://aeeps.ria.army.mil>. The DA Form 2028 is located under the Public Applications section on the AEPS public home page. Fill out the form and click on SUBMIT. Using this form on the AEPS site will enable us to respond to your comments quicker and to manage the DA Form 2028 program better. You may also mail, fax or e-mail your letter or DA Form 2028 directly to: AMSTA-LC-LMPP / TECH PUBS, TACOM-RI, 1 Rock Island Arsenal, Rock Island, IL 61299-7630. The e-mail address is ROCK-TACOM-TECH-PUBS@conus.army.mil. The fax number is DSN 793-0726 or Commercial (309) 782-0726.

CORROSION PREVENTION AND CONTROL (CPC)

Corrosion Prevention and Control (CPC) of Army materiel is a continuing concern. It is important that any corrosion problems with this item be reported so that the problem can be corrected and improvements can be made to prevent the problem in future items.

Corrosion specifically occurs with metals. It is an electrochemical process that causes the degradation of metals. It is commonly caused by exposure to moisture, acids, bases, or salts. An example is the rusting of iron. Corrosion damage in metals can be seen, depending on the metal, as tarnishing, pitting, fogging, surface residue, and/or cracking.

Plastics, composites, and rubbers can also degrade. Degradation is caused by thermal (heat), oxidation (oxygen), solvation (solvents), or photolytic (light, typically UV) processes. The most common exposures are excessive heat or light. Damage from these processes will appear as cracking, softening, swelling, and/or breaking.

If a corrosion problem is identified, it can be reported using SF 368 (Product Quality Deficiency Report). Use of key words such as "corrosion," "rust," "deterioration," or "cracking" will ensure that the information is identified as a CPC problem. The form should be submitted to the address specified in DA PAM 738-750, Functional Users Manual for The Army Maintenance Management System (TAMMS).

OZONE DEPLETING SUBSTANCES

There are no Ozone Depleting Substances (ODS) contained in the marine sanitation device.

DESTRUCTION OF ARMY MATERIEL TO PREVENT ENEMY USE

For procedures to destroy this equipment to prevent its use by the enemy, refer to TM 750-244-6, Procedures for Destruction of Tank - Automotive Equipment to Prevent Enemy Use.

PREPARATION FOR STORAGE OR SHIPMENT

Detailed procedures for preparing the marine sanitation device for storage or shipment are contained in TB 740-97-4, Preservation of Vessels for Storage and TM 38-470, Storage of Army Prepositioned Stock Materiel. The marine sanitation device must be prepared for storage or shipment in accordance with that publication.

WARRANTY INFORMATION

Unit maintenance maintains records of the warranty status of equipment on the marine sanitation device. The warranty starts on the date found in block 23 of DA Form 2408-9 (Equipment Control Record). Report all defects to your supervisor, who will take appropriate action.

LIST OF ABBREVIATIONS/ACRONYMS

Abbreviation/Acronym	Name
°C	Degrees Centigrade
°F	Degrees Fahrenheit
A	Ampere(s)
AAL	Additional Authorization List
AEPS	Army Electronic Product Support
AMP	Ampere(s)
AMS	Auxiliary Machinery Space
AUX	Auxiliary
bar	Air Pressure
BII	Basic Issue Items
BOI	Basis of Issue
cm	Centimeter(s)
CA	Compressed Air
CAGEC	Commercial And Government Entity Code
CHT	Collection, Holding, and Transfer
COEI	Components of End Item
CONN	Connection
COTS	Commercial Off The Shelf
COV	Cut Off Valve
CPC	Corrosion Prevention and Control
DA	Department of the Army
DA PAM	Department of the Army Pamphlet
DISCH	Discharge
EDIL	Expendable and Durable Items List
EIR	Equipment Improvement Recommendations
EOS	Enclosed Operating Space
ft	Foot(feet)
ft ²	Square foot(feet)
ft ³ /min	Cubic feet per minute
FGC	Functional Group Code
FM	Field Manual
FM	Flow Meter

LIST OF ABBREVIATIONS/ACRONYMS (continued)

Abbreviation/Acronym	Name
GAL	Gallon
GS	General Service
Hg	Mercury
HLDG	Holding
in	Inch(es)
in ³	Cubic Inch(es)
ISLN	Isolation
kg	Kilogram
L	Liter(s)
L/min	Liters per minute
lb	Pound(s)
lb-ft	Pounds Feet (torque)
LP	Low Pressure
LT	Large Tug
m	Meter(s)
m ²	Square meter(s)
mm	Millimeter(s)
mmHg	Millimeter(s) of Mercury
MAC	Maintenance Allocation Chart
MSD	Marine Sanitation Device
Nm	Newton Meter
NHA	Next Higher Assembly
NPT	National Pipe Thread
NSN	National Stock Number
ODS	Ozone Depleting Substance(s)
ppm	Parts Per Million
PG	Pressure Gauge
PMCS	Preventive Maintenance Checks and Services
PMP	Pump
P/N	Part Number
PNL	Panel
POTW	Potable Water
PPM	Parts Per Million
PRV	Pressure Relief Valve
PSI	Pounds per Square Inch
PSIG	Pounds per Square Inch (Gauge)
PW	Potable Water
PWR	Power
REV	Reverse
RPSTL	Repair Parts and Special Tools List
RV	Relief Valve

LIST OF ABBREVIATIONS/ACRONYMS (continued)

Abbreviation/Acronym	Name
SD	Sewage Discharge
SEP	Separator
SEW	Sewage
SMR	Source Maintenance and Recoverability
SOV	Shutoff Valve
SSDG	Ship's Service Diesel Generator
STBD	Starboard
SUCT	Suction
TAMMS	The Army Maintenance Management System
TK	Tank
TMDE	Test, Measurement, and Diagnostic Equipment
U/I	Unit of Issue
UOC	Useable On Code
UUT	Unit Under Test
UV	Ultraviolet
V	Valve
Vac	Volts, Alternating Current
Vdc	Volts, Direct Current
WP	Work Package
WTR	Water
WWTR	Waste Water
XFER	Transfer

QUALITY OF MATERIAL

Material used for replacement, repair, or modification must meet the requirements of this manual. If quality of material requirements are not stated in this manual, the material must meet the requirements of the drawings, standards, specifications, or approved engineering change proposals applicable to the subject equipment.

END OF WORK PACKAGE

**OPERATOR, UNIT, DIRECT SUPPORT, AND GENERAL SUPPORT MAINTENANCE
MARINE SANITATION DEVICE FOR
INLAND AND COASTAL LARGE TUG (LT)
EQUIPMENT DESCRIPTION AND DATA**

EQUIPMENT CHARACTERISTICS, CAPABILITIES, AND FEATURES

The Marine Sanitation Device (MSD) biologically oxidizes the organic matter in sewage and produces a clear odorless effluent. The MSD is comprised of a media tank, a chlorinator, wet well, discharge pump, blower, and miscellaneous gauges, valves, and piping. The technical characteristics of these components are detailed in the Equipment Data paragraph in this work package. Theory of operation is outlined in WP 0003 00.

LOCATION AND DESCRIPTION OF MAJOR COMPONENTS

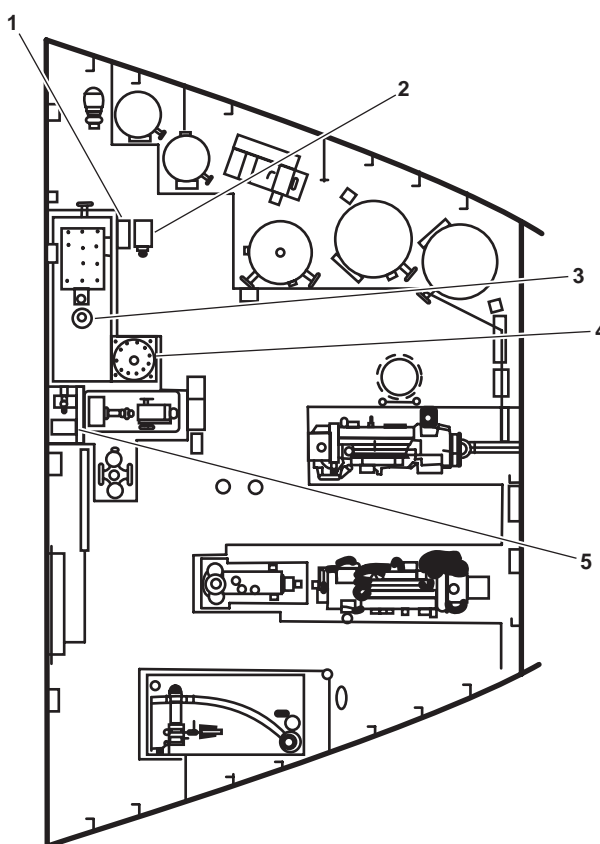

Figure 1. Major MSD Components

1. Chlorinator (figure 1, item 1). The tablet chlorinator is mounted between the spillover outlet of the media tank and the inlet to the wet well. This is a demand type chlorination system with no moving parts.
2. Discharge Pump (figure 1, item 2). The discharge pump automatically expels treated water overboard as the water level in the wet well rises.
3. Media Tank (figure 1, item 3). The tank stores and treats all waste matter produced aboard the vessel. Biological oxidation of sewage organics occurs within the tank as air lifts circulate the sewage and transfer oxygen into the water.

4. Wet Well (figure 1, item 4). The wet well is an independent freestanding tank located forward of the media tank. The wet well permits adequate disinfection time for media tank effluent during peak periods.
5. Blower Assembly (figure 1, item 5). The aeration blower is a rotary lobe positive displacement blower. The blower assembly is comprised of a blower, motor, V-Belt drive, drive guard, inlet silencer, relief valve, pressure gauge, and check valve.

DIFFERENCES BETWEEN MODELS

This manual applies to all LT 128' models that received the single pass chlorinator and MSD potable water fill modifications. No significant differences between models exist.

EQUIPMENT DATA

Table 1. Chlorinator Technical Characteristics

Item	Data
Manufacturer	NORWECO
Model	LF-500
Maximum Flow Through Rate	500 gal/day (1893 L/day)
Peak Flow Factor	4

Table 2. Blower Technical Characteristics

Item	Data
Manufacturer	Roots
Model	22
Motor	
HP (kW)	1.0 (0.75)
Speed	3450 r/min
Output	46 ft ³ /min (1.30 m ³ /min)
Pressure	2 PSI (0.14 bar)
Relief valve pressure	3.0 PSI (0.21 bar) max
Blower discharge pressure	0-15 PSI (0-1.0 bar)

Table 3. Basket Strainer

Item	Data
Manufacturer	Hayward
Model	72
Basket	Brass basket with 1/4 inch (6 mm) diameter perforated holes

Table 4. MSD Discharge Pump

Item	Data
Manufacturer	MP Pumps
Model	110
Inlet Size	1 1/2 inch (37 mm)
Outlet Size	1 1/4 inch (31 mm)
Housing Material	Bronze
Impeller Material	Bronze
Output rating	50 gal/min (189 L/min) at 42 feet (12.8 meter) discharge head

END OF WORK PACKAGE

**OPERATOR, UNIT, DIRECT SUPPORT, AND GENERAL SUPPORT MAINTENANCE
MARINE SANITATION DEVICE FOR
INLAND AND COASTAL LARGE TUG (LT)
THEORY OF OPERATION**

GENERAL

The Marine Sanitation Device (MSD) receives, treats, and discharges all sewage generated aboard the LT. The system is comprised of a vented media tank, chlorinator, wet well, discharge pump, and blower.

SYSTEM

All raw sewage from the toilets on the main deck and 01 level flows to the media tank (figure 1, item 1). Potable water for flushing carries waste from the toilets to the media tank using 4" drain lines and 1 ½" vents.

The water level in the media tank is maintained at a constant level. As raw sewage enters the media tank via the 4" inlet (figure 1, item 2), an equal volume of treated clear effluent is displaced into the spillover pipe (figure 1, item 3). This effluent passes through the tablet chlorinator (figure 1, item 4), where it is disinfected.

As the water passes through the tablet chlorinator (figure 1, item 4), calcium hypochlorite tablets are dissolved, releasing chlorine into the effluent. The amount of chlorine released is proportional to flow. A full feed tube (figure 1, item 5) holds 20 five-ounce tablets, equaling 6.25 lb (2.83 kg). Expected tablet consumption is determined by water usage. Leaking fixtures will greatly increase water usage and tablet consumption.

Clear and odorless water flows from the media tank (figure 1, item 1) through the spillover pipe (figure 1, item 3) and trap into the wet well (figure 1, item 6). The wet well is a retention tank sized for adequate disinfection time during peak flow periods. The wet well vent (figure 1, item 7) is open to the immediate environment. The disinfected water is discharged overboard by the discharge pump (figure 1, item 8).

The discharge pump (figure 1, item 8) handles the peak flows expected for the system. The pump assembly includes a pump, isolation valve, discharge pressure gauge, float switch for automatic operation, motor, and a motor starter. As the water level in the wet well rises, the "pump on" float switch automatically starts the discharge pump, which discharges the water overboard. When sufficient effluent is discharged from the wet well, the float switch stops the discharge pump.

A separate sewage holding tank holds sewage during maintenance or transfer of sewage or graywater to a shore connection. Piping is provided to bypass the Marine Sanitation Device (MSD), sending sewage and graywater (wastewater system) directly to the holding tank. Two pumps are provided for the sewage holding tank (SEWAGE DISCHARGE PUMP NO. 1 and SEWAGE DISCHARGE PUMP NO. 2) so that the tank contents can be pumped overboard or to shore. A connection is also provided between the MSD media tank and the sewage holding tank, allowing the contents of the media tank to be drained by gravity to the sewage holding tank for maintenance.

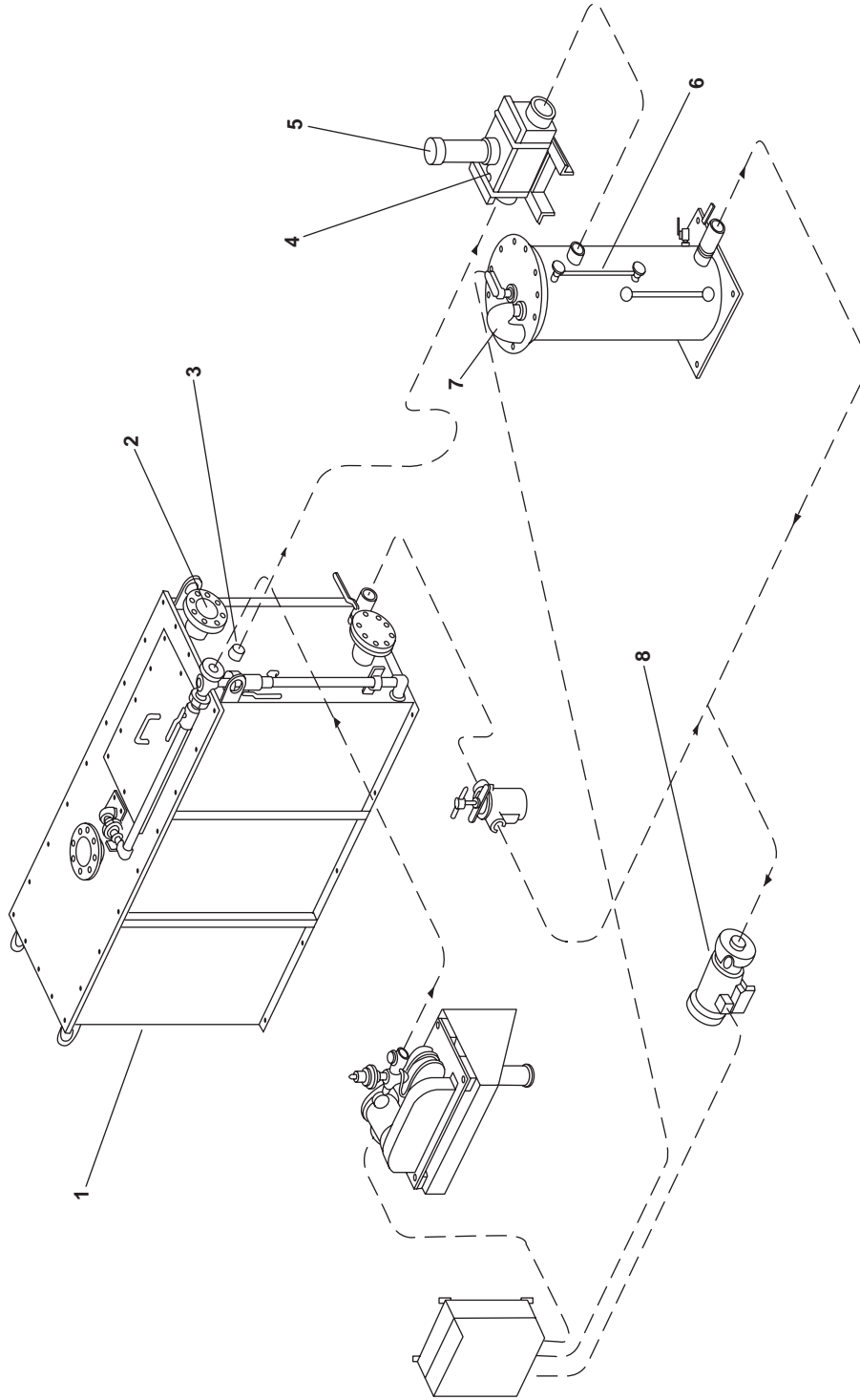

Figure 1. MSD Schematic

END OF WORK PACKAGE

Chapter 2

**Operator Instructions
for
Marine Sanitation Device**

Inland and Coastal Large Tug (LT)

**OPERATOR, UNIT, DIRECT SUPPORT, AND GENERAL SUPPORT MAINTENANCE
MARINE SANITATION DEVICE FOR
INLAND AND COASTAL LARGE TUG (LT)
DESCRIPTION AND USE OF OPERATOR CONTROLS AND INDICATORS**

MARINE SANITATION DEVICE (MSD) CONTROL PANEL

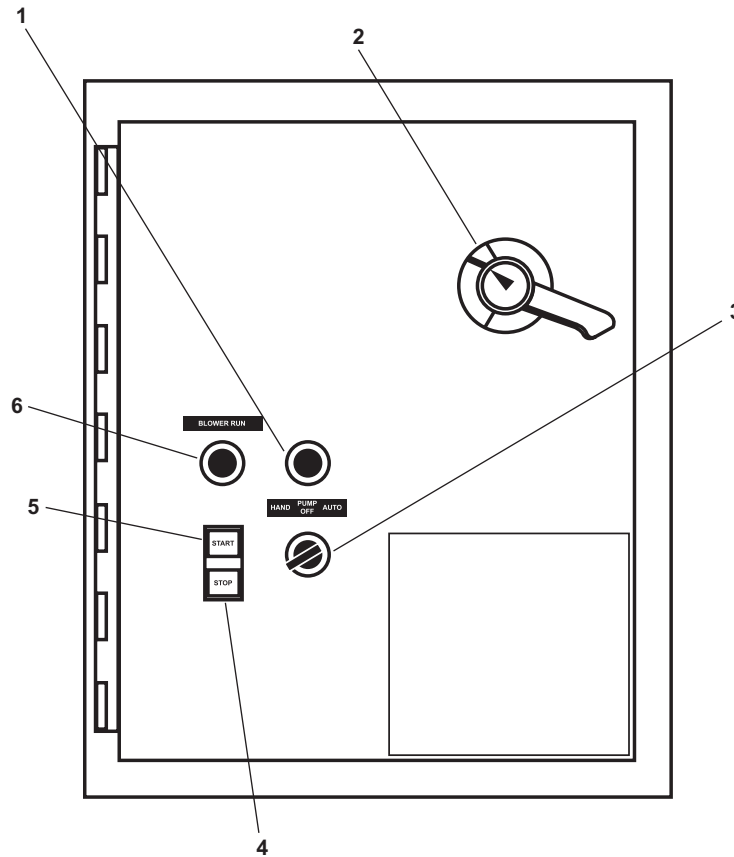

Figure 1. MSD Control Panel

Table 1. MSD Control Panel (Refer to figure 1)

Key	Control/Indicator	Function
1	Pump Running Indicator	This indicator illuminates when the MSD discharge pump is operating.
2	Power ON/OFF/RESET	This switch turns power to the MSD control panel ON and OFF. Switch The switch must be in the RESET position to open the MSD control panel door.
3	HAND/PUMP OFF/AUTO Selector Switch	This switch selects the MSD discharge pump mode of operation. In the PUMP OFF, position the MSD discharge pump is not operational. In the HAND position, the MSD discharge pump is controlled by the operator. In the AUTO position, the MSD discharge pump operates automatically.

Table 1. MSD Control Panel (Refer to figure 1) (continued)

Key	Control/Indicator	Function
4	Blower STOP Pushbutton	This pushbutton is used to STOP the blower.
5	Blower START Pushbutton	This pushbutton is used to START the blower.
6	Blower Running Indicator	This indicator illuminates when the blower is operating.

440V POWER PANEL NO. 4

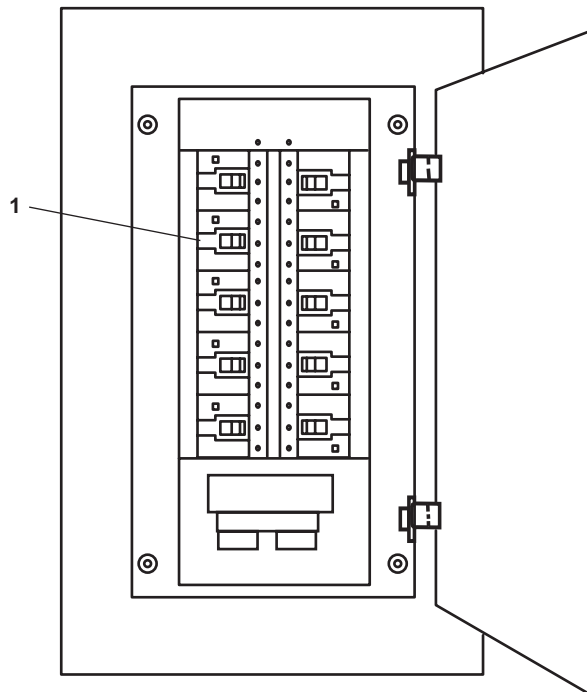

Figure 2. 440V Power Panel No. 4

Table 2. 440V Power Panel No. 4 (Refer to figure 2)

Key	Control/Indicator	Function
1	MSD DISCHARGE PUMP AND BLOWER circuit breaker (LT 803 Only) CONTROLLER FOR MSD DISCHARGE PUMP AND BLOWER circuit breaker (All Other Vessels)	This circuit breaker provides circuit protection for the MSD control panel.

SEWAGE DISCHARGE PUMP CONTROLLER

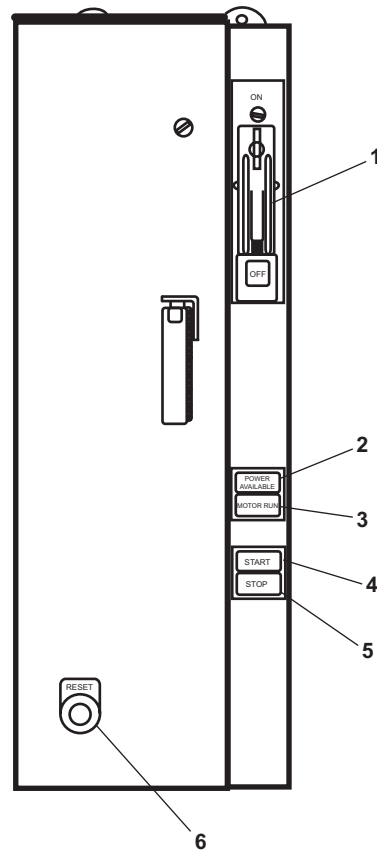

Figure 3. Sewage Discharge Pump Controller

Table 3. Sewage Discharge Pump Controller (Refer to figure 3)

Key	Control/Indicator	Function
1	ON/OFF Switch	This switch serves as a disconnect switch for the sewage discharge pump controller.
2	POWER AVAILABLE indicator	This indicator illuminates to indicate that power is available to the controller.
3	MOTOR RUN Indicator	This indicator illuminates to indicate that the motor is running.
4	START Pushbutton	This pushbutton is used to START the sewage discharge pump motor.
5	STOP Pushbutton	This pushbutton is used to STOP the sewage discharge pump motor.
6	RESET Pushbutton	This pushbutton is used to RESET the sewage discharge pump controller.

440V POWER PANEL NO. 1

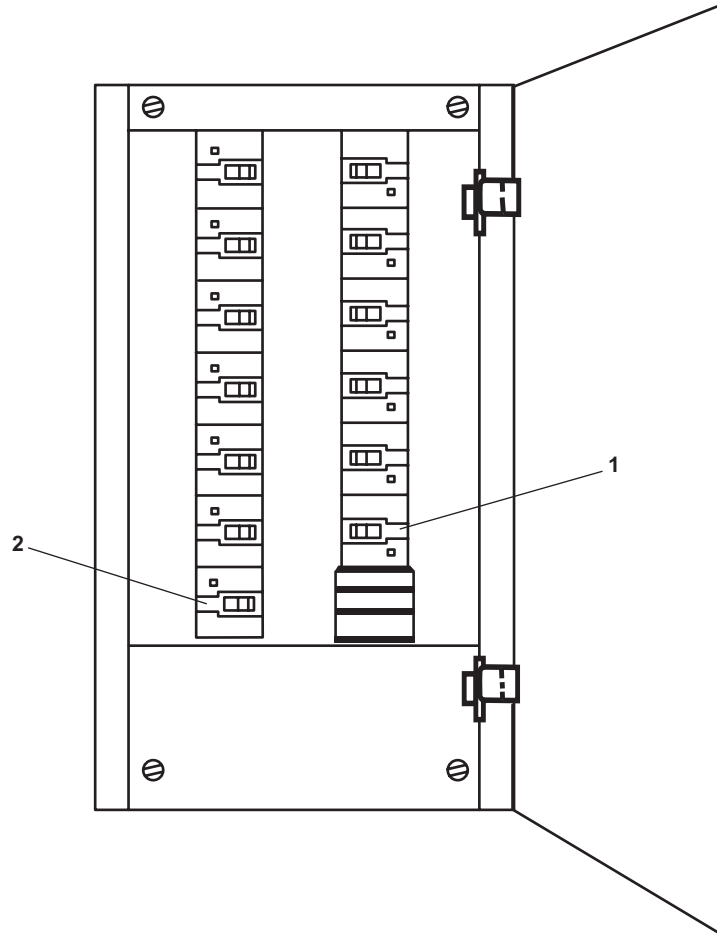

Figure 4. 440V Power Panel No. 1

Table 4. 440V Power Panel No. 1 (Refer to figure 4)

Key	Control/Indicator	Function
1	SEWAGE DISCHARGE PUMP No. 1 circuit breaker (LT 803 Only) LVP FOR STARBOARD SEWAGE DISCHARGE PUMP No. 1 circuit breaker (All Other Vessels)	This circuit breaker provides circuit protection for sewage discharge pump No. 1 controller.
2	SEWAGE DISCHARGE PUMP No. 2 circuit breaker (LT 803 Only) LVP FOR PORT SEWAGE DISCHARGE PUMP No. 2 circuit breaker (All Other Vessels)	This circuit breaker provides circuit protection for sewage discharge pump No. 2 controller.

MSD VALVES, AMS 1

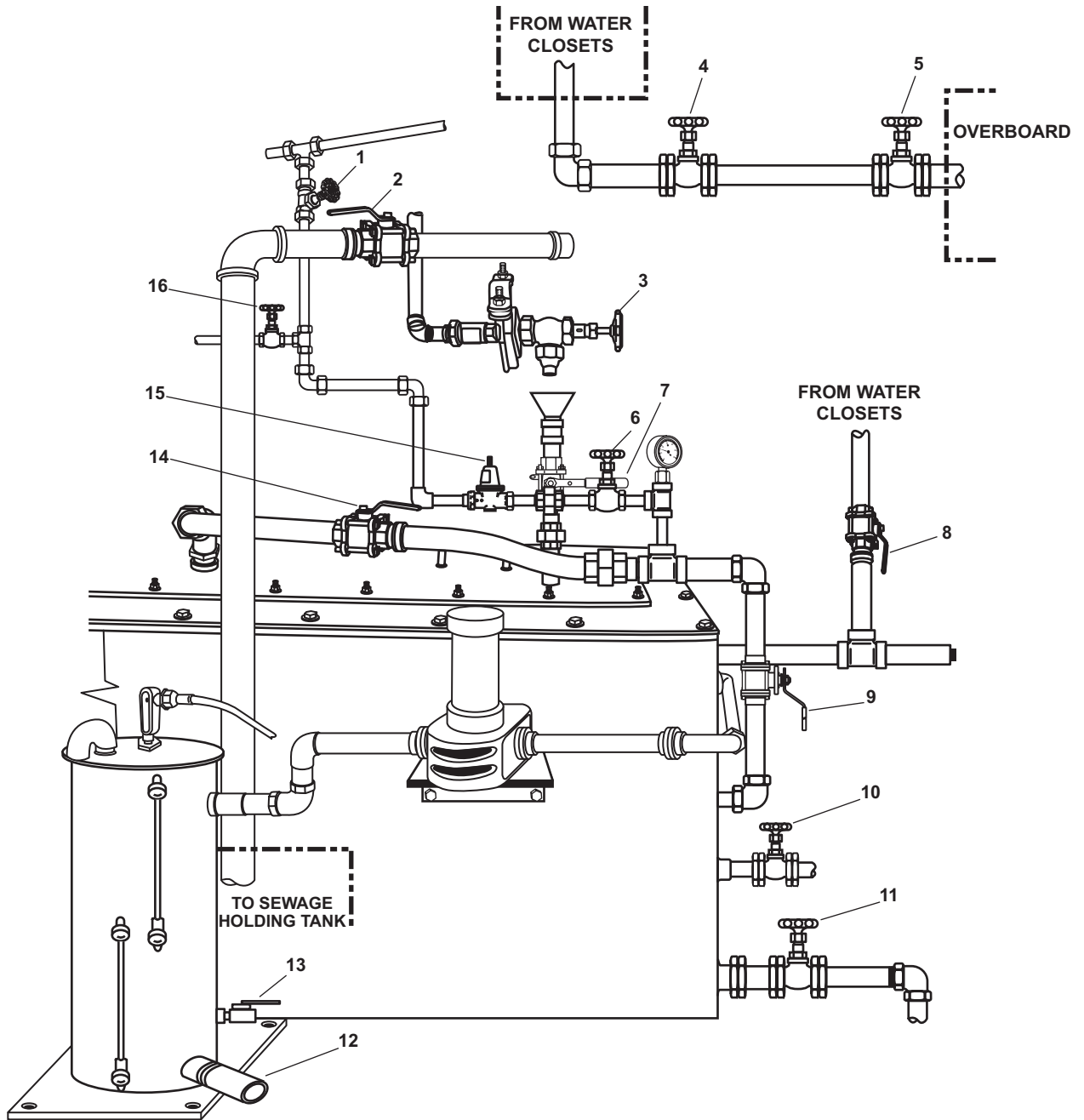

Figure 5. MSD Valves, AMS 1

Table 5. MSD Valves, AMS 1 (Refer to figure 5)

Key	Control/Indicator	Function
1	CA-80 COV-LP AIR	This valve secures the ship's service low pressure air shutoff.
2	SD-3 SEWAGE DRAIN TO HOLDING TANK	This valve allows sewage to go directly to the sewage holding tank when OPENED.
3	PW-100 POTW ISOLATION	OPEN this valve to allow potable water to the MSD potable water fill valve.
4	SD-2 SEWAGE OVERBOARD DISCHARGE	OPEN this valve to allow sewage to the overboard discharge.
5	SD-13 SEWAGE OVERBOARD DISCHARGE	This valve, when OPENED, allows sewage to be discharged overboard.
6	CA-81 LP AIR SHUTOFF	This valve, when CLOSED, stops the ship's service compressed air from entering the MSD system.
7	MSD-3 POTW FILL TO MSD ISLN	This valve, when OPENED, permits potable water to fill the media tank.
8	SD-1 SEWAGE INLET TO MSD	This valve, when OPENED, permits sewage to enter the MSD.
9	MSD-6 BLOWER DISCH TO AIR SCOURING SOV	OPEN this valve to air scour the MSD media tank.
10	MSD-8 MEDIA TANK PUMP-OUT DR	OPEN this valve to pump out the MSD media tank.
11	MSD-9 MEDIA TANK DRAIN	OPEN this valve to drain the media tank to the sewage holding tank.
12	MSD-10 WET WELL DISCHARGE	OPEN this valve to allow effluent to the MSD discharge pump.
13	MSD-11 WET WELL SAMPLE	This valve, when OPENED, permits samples to be taken from the wet well.
14	MSD-5 BLOWER DISCHARGE SHUTOFF	This valve, when CLOSED, isolates the blower from the media tank.
15	CA-83 PRV SET AT 2 PSIG	This valve regulates the amount of air pressure entering the media tank from the ship's service low pressure air.
16	CA-82 LP AIR HOSE SHUTOFF	This valve, when CLOSED, isolates the ship's service low pressure air.

MSD VALVES, ENGINE ROOM FORWARD

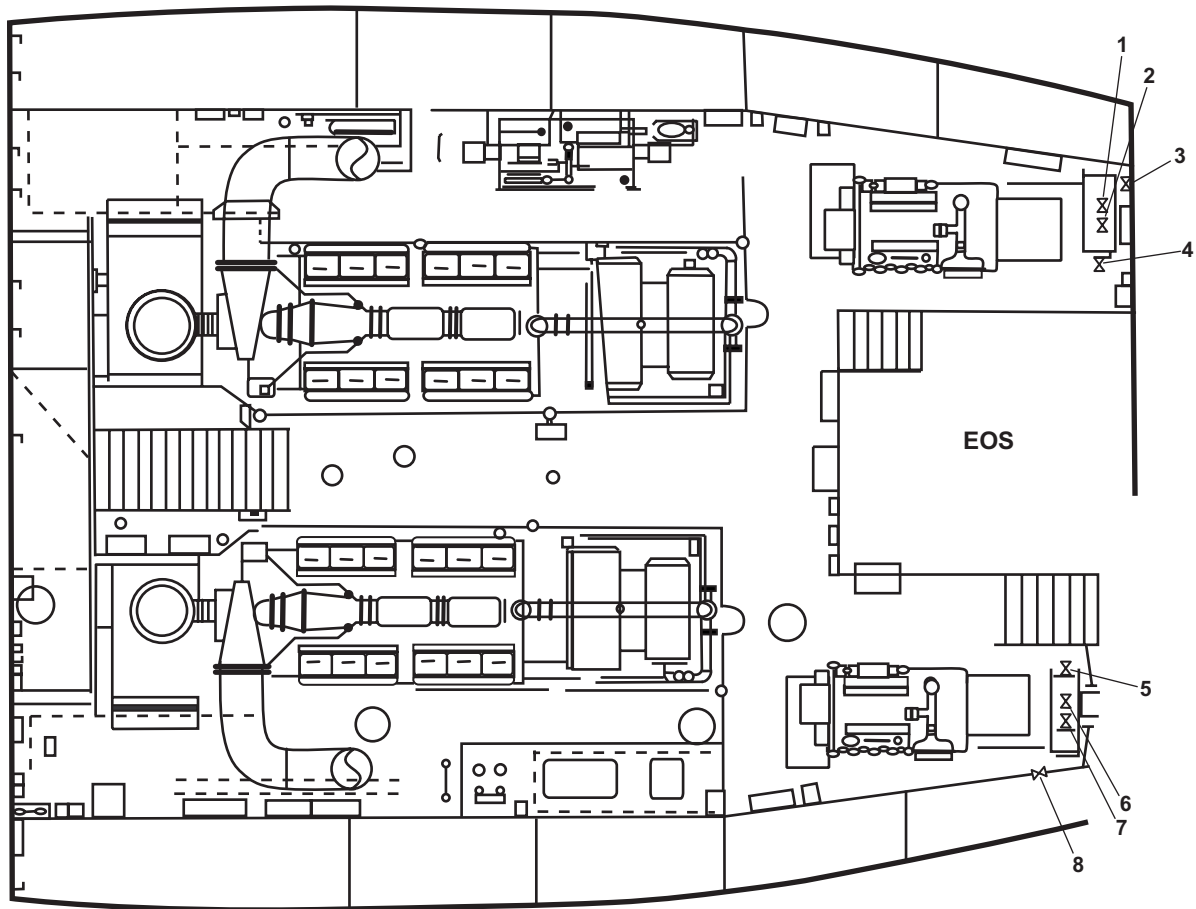

Figure 6. MSD Valves, Engine Room Forward

Table 6. MSD Valves, Engine Room Forward (Refer to figure 6)

Key	Control/Indicator	Function
1	SD-6 COV-SEW DISCH PMP NO. 2 DISCH	This valve, when CLOSED, isolates the discharge of sewage pump No. 2.
2	SD-20 SEW PMP NO. 2 DISCH PRESS GAGE ISLN	This valve, when CLOSED, isolates the pressure gauge to sewage pump No. 2.
3	SD-8 SEWAGE OVERBOARD DISCHARGE	This valve, when CLOSED, isolates the sewage to shore connection.
4	SD-4 COV-SEW DISCH PMP NO. 2 SUCT PMP NO. 2 SUCT	This valve, when CLOSED, isolates the suction side of sewage pump No. 2.
5	SD-5 COV-SEW DISCH PMP NO. 1 SUCT	This valve, when CLOSED, isolates the suction side of sewage pump No. 1.

Table 6. MSD Valves, Engine Room Forward (Refer to figure 6) (continued)

Key	Control/Indicator	Function
6	SD-19 SEW PMP NO. 1 DISCH PRESS GAGE ISLN	This valve, when CLOSED, isolates the pressure gauge to sewage pump No. 1.
7	SD-7 COV-SEW DISCH PMP NO. 1 DISCH	This valve, when CLOSED, isolates the discharge of sewage pump No. 1.
8	SD-9 SEWAGE TO SHORE CONN	This valve, when CLOSED, isolates the sewage to shore connection.

END OF WORK PACKAGE

**OPERATOR, UNIT, DIRECT SUPPORT, AND GENERAL SUPPORT MAINTENANCE
MARINE SANITATION DEVICE FOR
INLAND AND COASTAL LARGE TUG (LT)
OPERATION UNDER USUAL CONDITIONS**

INITIAL SETUP:

Materials/Parts:

- Gloves, Chemical and Oil Protective (Item 1, Table 3, WP 0038 00)
- Goggles, Industrial (Item 2, Table 3, WP 0038 00)
- Tag, Danger (Item 7, Table 1, WP 0039 00)

References:

- FM 55-502
- TM 55-1925-273-10
- WP 0014 00
- WP 0038 00
- WP 0039 00

Personnel Required:

- One Watercraft Engineer, 88L

Equipment Conditions:

- All ventilation fans operating normally (TM 55-1925-273-10)

SECURITY MEASURES FOR ELECTRONIC DATA

There are no required security measures for electronic data. The Marine Sanitation Device (MSD) components do not use or store any electronic data.

OPERATION UNDER USUAL CONDITIONS

SYSTEM STARTUP

NOTE

The System Startup procedure is performed after the following: New System Installation, System Lay Up, System Overhaul, Air Scour and Pump Out of the Media Tank (WP 0014 00), and Cleaning of the Media Tank (WP 0014 00).

1. Set to ON the AUX MACH SPACE NO. 1 PWR PNL NO. 4 circuit breaker (figure 1, item 1) at the main switchboard (figure 1, item 2) in the Enclosed Operating Space (EOS).

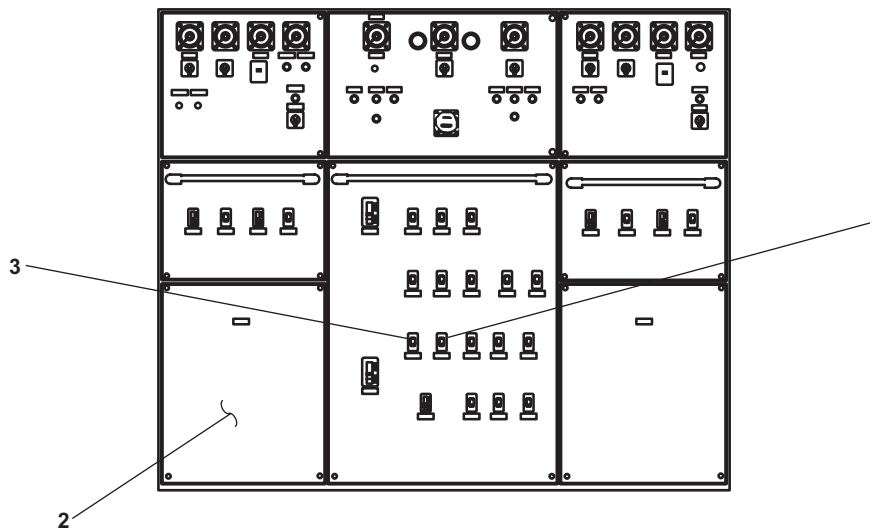

Figure 1. Main Switchboard Circuit Breakers

2. Set to ON the MSD DISCHARGE PUMP AND BLOWER circuit breaker (**LT 803 Only**), or the CONTROLLER FOR MSD DISCHARGE PUMP AND BLOWER circuit breaker (**All Other Vessels**) (figure 2, item 1) in 440V power panel No. 4.

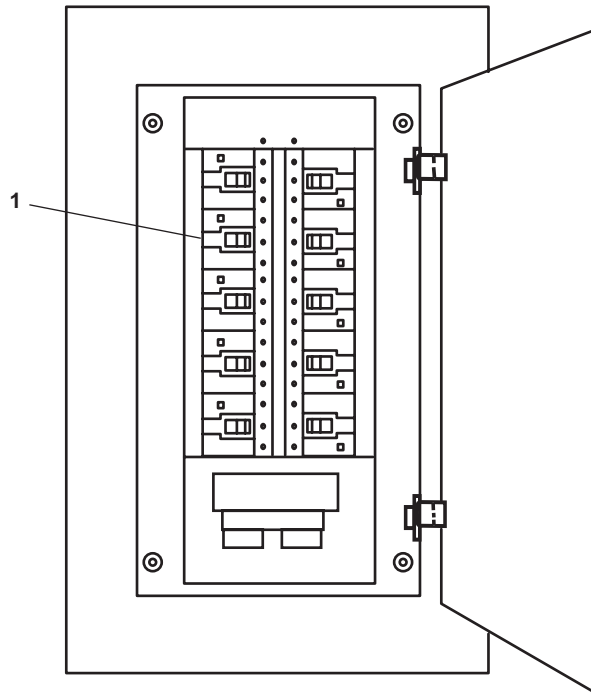

Figure 2. 440V Power Panel No. 4

NOTE

Pay particular attention to valve lineup. Sewage can back up in the system if valves SD-2 SEWAGE OVERBOARD DISCHARGE, SD-3 SEWAGE DRAIN TO HOLDING TANK, and SD-1 SEWAGE INLET TO MSD VALVES are CLOSED.

3. Align the valves for the MSD to operate under usual conditions as specified in figure 3 and table 1.

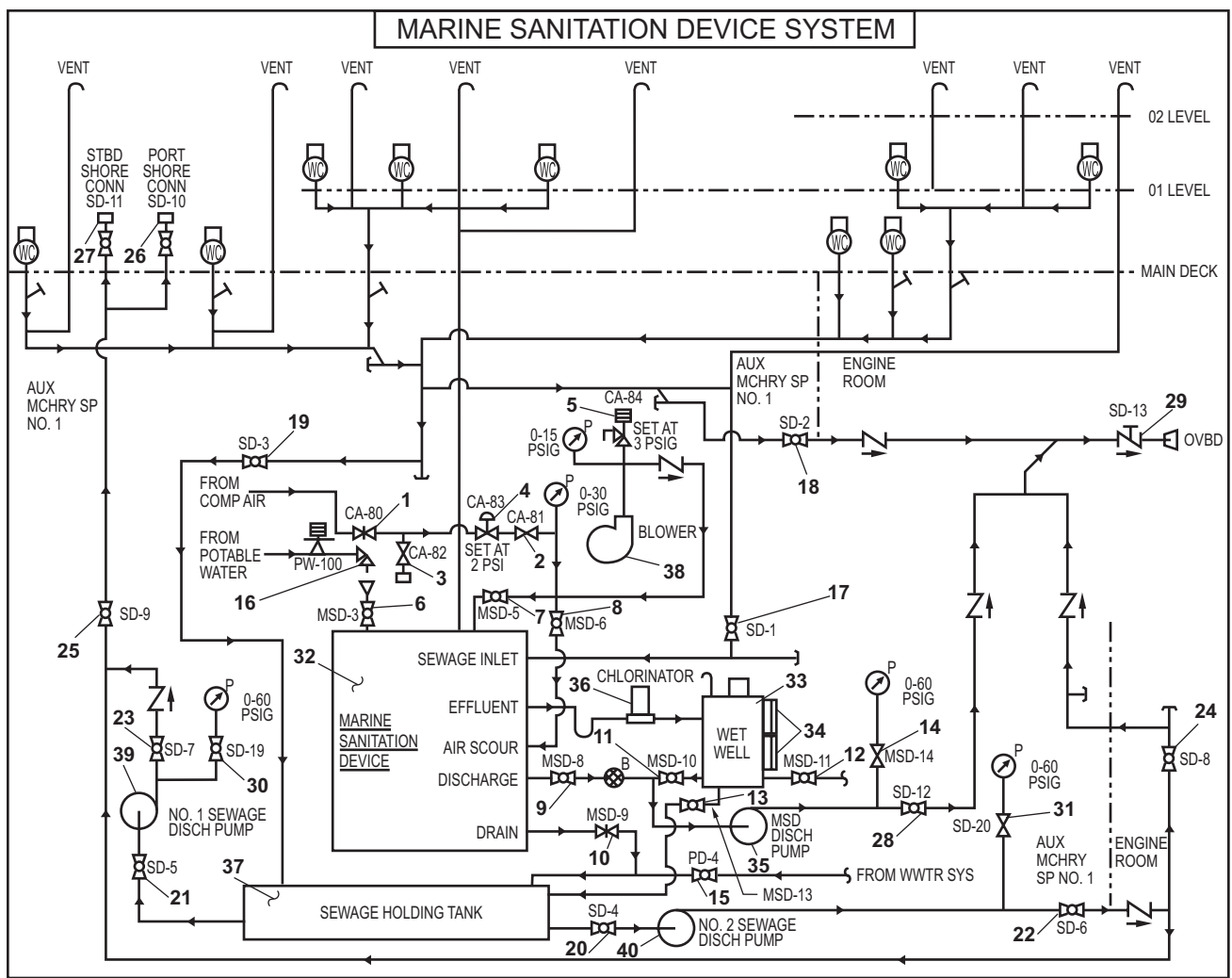

Figure 3. MSD System Schematic

Table 1. Valve Alignment Under Usual Conditions

Item Number (Figure 3)	Valve Number	Function	Position During Operation Under Usual Conditions
1	CA-80	COV-LP AIR	CLOSED
2	CA-81	COV-LP AIR	CLOSED
3	CA-82	LP AIR HOSE SHUTOFF	CLOSED
4	CA-83	PRV-SET AT 2 PSIG	Factory Set
5	CA-84	RV-SET AT 3 PSIG	Factory Set
6	MSD-3	POTW FILL TO MSD ISLN	CLOSED
7	MSD-5	BLOWER DISCHARGE SHUTOFF	OPEN

Table 1. Valve Alignment Under Usual Conditions (continued)

Item Number (Figure 3)	Valve Number	Function	Position During Operation Under Usual Conditions
8	MSD-6	BLOWER DISCH TO AIR SCOURING SOV	CLOSED
9	MSD-8	MEDIA TANK PUMP-OUT DR	CLOSED
10	MSD-9	MEDIA TANK DRAIN	CLOSED
11	MSD-10	WET WELL DISCHARGE	OPEN
12	MSD-11	WET WELL SAMPLE	CLOSED
13	MSD-13	WET WELL DRAIN TO HOLDING TANK	CLOSED
14	MSD-14	MSD DISCH PUMP GAGE ISLN	OPEN
15	PD-4	WASTE WTR TO SEW HLDG TANK	OPEN
16	PW-100	POTW ISOLATION	CLOSED
17	SD-1	SEWAGE INLET TO MSD	OPEN
18	SD-2	SEWAGE OVERBOARD DISCHARGE	CLOSED
19	SD-3	SEWAGE DRAIN TO HOLDING TANK	CLOSED
20	SD-4	COV-SEW DISCH PMP NO. 2 SUCT	CLOSED
21	SD-5	COV-SEW DISCH PMP NO. 1 SUCT	CLOSED
22	SD-6	COV-SEW DISCH PMP NO. 2 DISCH	CLOSED
23	SD-7	COV-SEW DISCH PMP NO. 1 DISCH	CLOSED
24	SD-8	SEWAGE OVERBOARD DISCHARGE	CLOSED
25	SD-9	SEWAGE TO SHORE CONN	CLOSED
26	SD-10	SEWAGE SHORE CONN PORT	CLOSED
27	SD-11	SEWAGE SHORE CONN STBD	CLOSED
28	SD-12	MSD OVERBOARD DISCH PMP DISCH	OPEN
29	SD-13	SEWAGE OVERBOARD DISCHARGE	OPEN
30	SD-19	SEW PMP NO. 1 DISCH PRESS GAGE ISLN	CLOSED
31	SD-20	SEW PMP NO. 2 DISCH PRESS GAGE ISLN	CLOSED

4. OPEN MSD-3 POTW FILL TO MSD ISLN (figure 3, item 6) and PW-100 POTW ISOLATION (figure 3, item 16) valves and fill the media tank (figure 3, item 32) with potable water. Fill the media tank until the water in the wet well (figure 3, item 33) reaches a level halfway up the wet well sight glass (figure 3, item 34).
5. CLOSE MSD-3 POTW FILL TO MSD ISLN (figure 3, item 6) and PW-100 POTW ISOLATION (figure 3, item 16) valves.
6. Ensure that chlorine tablets have been installed in the chlorinator (figure 3, item 36) (WP 0014 00).
7. Set to ON the MSD control panel master switch (figure 4, item 1).
8. Press the START button (figure 4, item 2) on the MSD control panel (figure 4, item 3) to start the blower (figure 3, item 38).
9. Set the PUMP HAND/OFF/AUTO switch (figure 4, item 4) on the MSD control panel (figure 4, item 3) to AUTO.

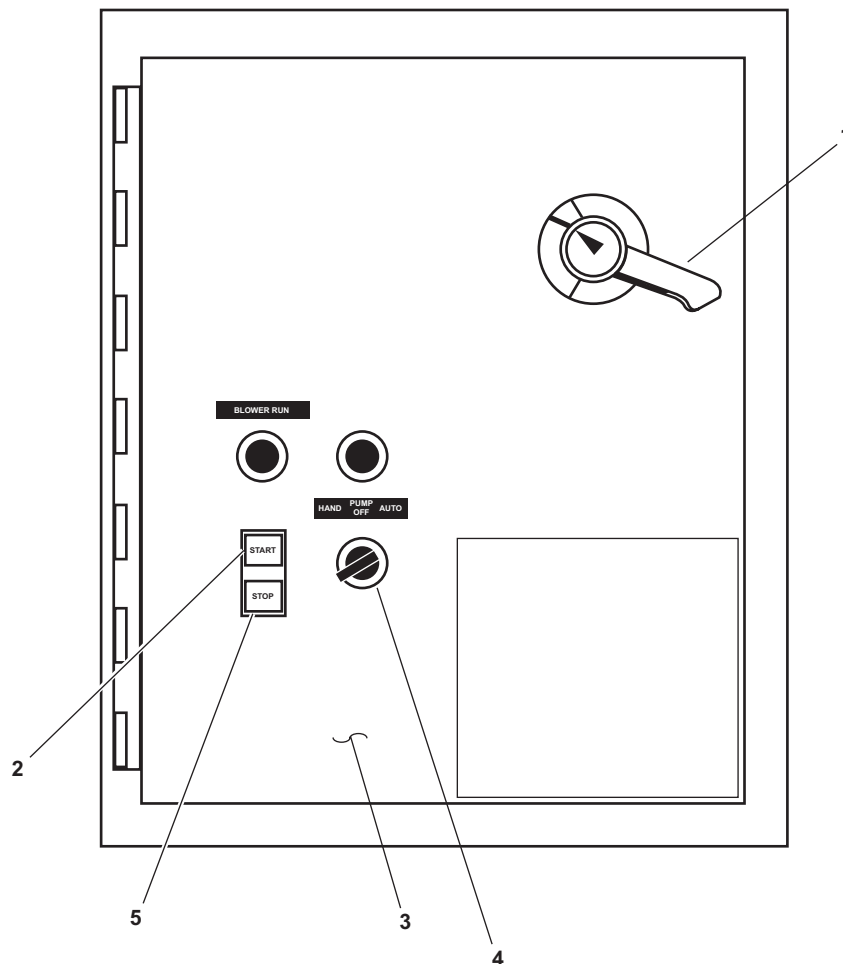

Figure 4. MSD Control Panel

NOTE

It will take approximately two weeks for bacterial culture to grow to normal operating strength. During this period, system effluent may change from clear to cloudy. If the bacterial culture has started properly, it will revert to clear.

10. Verify that SD-1 SEWAGE INLET TO MSD (figure 3, item 17) valve is OPEN to allow sewage to flow into the media tank (figure 3, item 32).

SEWAGE HOLDING TANK TO SHORE CONNECTION

NOTE

Either one or both of the sewage discharge pumps can be used to pump sewage to the shore discharge connections.

1. Ensure that the shore connection hoses are in good working order and connected to the vessel and the shore facility.
2. Perform the Air Scour and Pump Out Media Tank procedure (WP 0014 00).
3. Align the valves for the sewage holding tank to shore connection as specified in figure 3 and table 2.

Table 2. Valve Alignment for Sewage Holding Tank To Shore Connection

Item Number (Figure 3)	Valve Number	Function	Position During Operation Under Usual Conditions
1	CA-80	COV-LP AIR	CLOSED
2	CA-81	COV-LP AIR	CLOSED
3	CA-82	LP AIR HOSE SHUTOFF	CLOSED
4	CA-83	PRV-SET AT 2PSIG	Factory Set
5	CA-84	RV-SET AT 3 PSIG	Factory Set
6	MSD-3	POTW FILL TO MSD ISLN	CLOSED
7	MSD-5	BLOWER DISCHARGE SHUTOFF	CLOSED
8	MSD-6	BLOWER DISCH TO AIR SCOURING SOV	CLOSED
9	MSD-8	MEDIA TANK PUMP-OUT DR	CLOSED
10	MSD-9	MEDIA TANK DRAIN	CLOSED
11	MSD-10	WET WELL DISCHARGE	CLOSED
12	MSD-11	WET WELL SAMPLE	CLOSED
13	MSD-13	WET WELL DRAIN TO HOLDING TANK	CLOSED

Table 2. Valve Alignment for Sewage Holding Tank To Shore Connection (continued)

Item Number (Figure 3)	Valve Number	Function	Position During Operation Under Usual Conditions
14	MSD-14	MSD DISCH PUMP GAGE ISLN	CLOSED
15	PD-4	WASTE WTR TO SEW HLDG TANK	OPEN
16	PW-100	POTW ISOLATION	CLOSED
17	SD-1	SEWAGE INLET TO MSD	CLOSED
18	SD-2	SEWAGE OVERBOARD DISCHARGE	CLOSED
19	SD-3	SEWAGE DRAIN TO HOLDING TANK	CLOSED
20	SD-4	COV-SEW DISCH PMP NO. 2 SUCT	CLOSED
21	SD-5	COV-SEW DISCH PMP NO. 1 SUCT	CLOSED
22	SD-6	COV-SEW DISCH PMP NO. 2 DISCH	CLOSED
23	SD-7	COV-SEW DISCH PMP NO. 1 DISCH	CLOSED
24	SD-8	SEWAGE OVERBOARD DISCHARGE	CLOSED
25	SD-9	SEWAGE TO SHORE CONN	CLOSED
26	SD-10	SEWAGE SHORE CONN PORT	CLOSED
27	SD-11	SEWAGE SHORE CONN STBD	CLOSED
28	SD-12	MSD OVERBOARD DISCH PMP DISCH	CLOSED
29	SD-13	SEWAGE OVERBOARD DISCHARGE	CLOSED
30	SD-19	SEW PMP NO. 1 DISCH PRESS GAGE ISLN	CLOSED
31	SD-20	SEW PMP NO. 2 DISCH PRESS GAGE ISLN	CLOSED

4. Set to ON the ENGINE ROOM POWER PANEL NO. 1 circuit breaker (figure 1, item 3) at the main switchboard (figure 1, item 2) in the EOS.
5. To operate sewage discharge pump No.1 (figure 3, item 39), set to ON the SEWAGE DISCHARGE PUMP No. 1 circuit breaker (**LT 803 Only**), or the LVP FOR STARBOARD SEWAGE DISCHARGE PUMP No. 1 circuit breaker (**All Other Vessels**) (figure 5, item 1) in the 440V power panel No. 1 (figure 5, item 2).
6. OPEN SD-5 (figure 3, item 21), SD-7 (figure 3, item 23), SD-9 (figure 3, item 25), SD-19 (figure 3, item 30). To pump to the port shore connection, OPEN SD-10 (figure 3, item 26). To pump to the starboard shore connection, OPEN SD-11 (figure 3, item 27).

7. To operate sewage discharge pump No. 2 (figure 3, item 40), set to ON the SEWAGE DISCHARGE PUMP No. 2 circuit breaker (**LT 803 Only**), or the LVP FOR PORT SEWAGE DISCHARGE PUMP No. 2 circuit breaker (**All Other Vessels**) (figure 5, item 3) in the 440V power panel No. 1 (figure 5, item 2).

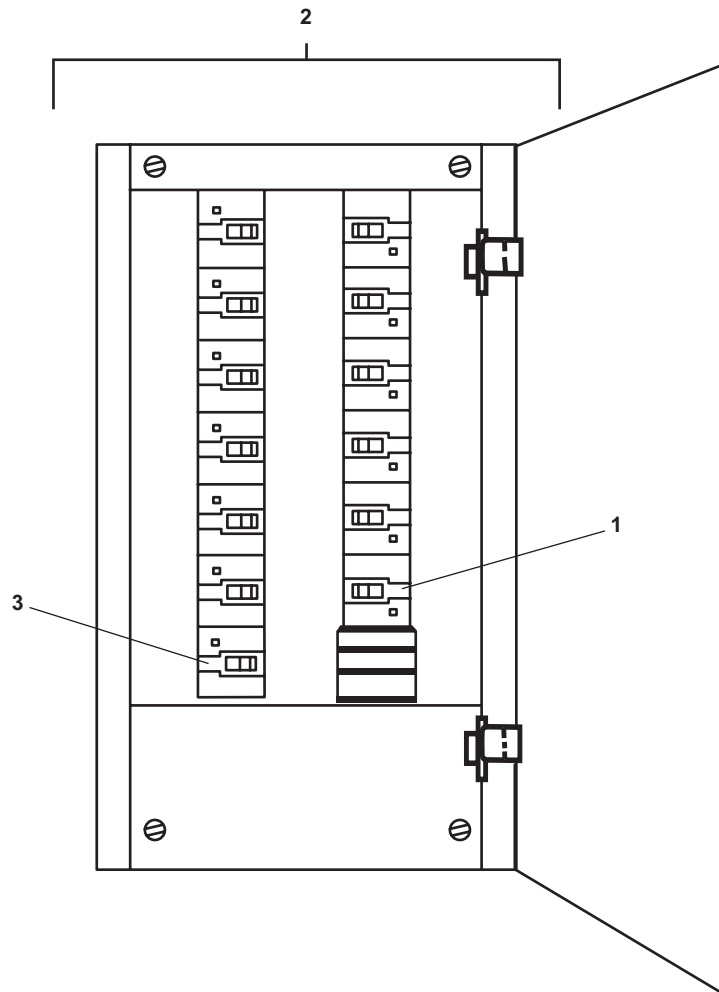

Figure 5. 440V Power Panel No. 1

8. OPEN SD-4 (figure 3, item 20), SD-6 (figure 3, item 22), SD-9 (figure 3, item 25), and SD-20 (figure 3, item 31). Ensure that SD-8 (figure 3, item 24) is closed. To discharge to the port shore connection, OPEN SD-10 (figure 3, item 26). To pump to the starboard shore connection, OPEN SD-11 (figure 3, item 27).
9. Set the ON/OFF switch (figure 6, item 1) to the applicable SEWAGE DISCHARGE PUMP CONTROLLER (figure 6, item 2) to ON.
10. Press the START button (figure 6, item 3). Verify that the motor run light (figure 6, item 4) is illuminated.
11. Monitor the sewage level in the sewage holding tank by checking the tank level indicator (figure 7, item 1) in the AMS 1 to prevent the sewage discharge pump from running dry.
12. Press the STOP button (figure 6, item 5) on the applicable SEWAGE DISCHARGE PUMP CONTROLLER (figure 6, item 2).

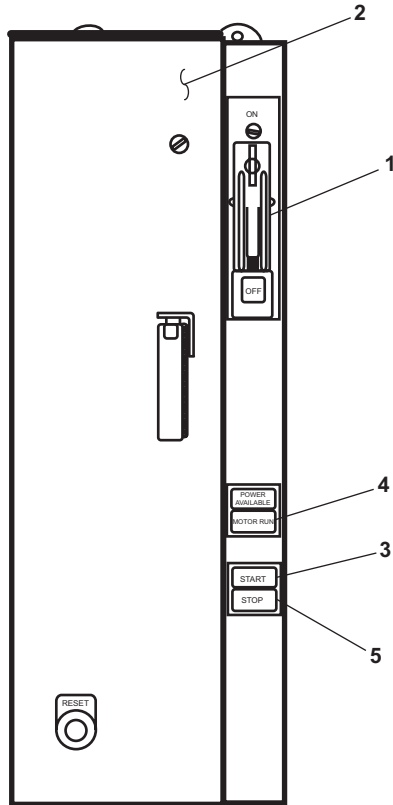

Figure 6. Sewage Discharge Pump Controller

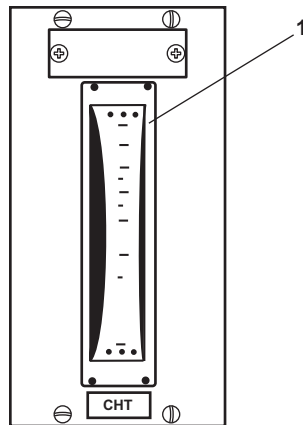

Figure 7. CHT Tank Level Indicator

13. Set the applicable ON/OFF switch (figure 6, item 1) to the SEWAGE DISCHARGE PUMP CONTROLLER (figure 6, item 2) to the OFF position.
14. Set to OFF the SEWAGE DISCHARGE PUMP No. 1 circuit breaker (**LT 803 Only**), or the LVP FOR STARBOARD SEWAGE DISCHARGE PUMP No. 1 circuit breaker (**All Other Vessels**) (figure 5, item 1) and the SEWAGE DISCHARGE PUMP No. 2 circuit breaker (**LT 803 Only**), or the LVP FOR PORT SEWAGE DISCHARGE PUMP No. 2 circuit breaker (**All Other Vessels**) (figure 5, item 3) in the 440V power panel No. 1 (figure 5, item 2).
15. Align the valves for the MSD as specified in figure 3 and table 2.
16. Perform the System Start Up procedure in this work package.

SYSTEM SHUTDOWN

NOTE

The System Shutdown procedure is performed for the following reasons: System Lay Up, System Overhaul, Air Scour and Pump Out of the Media Tank, and Cleaning of the Media Tank.

1. Perform the Sewage Holding Tank To Shore Connection procedure in this work package.
2. Set the PUMP HAND OFF AUTO switch (figure 4, item 4) on the MSD control panel (figure 4, item 3) to the OFF position.
3. Set to OFF the aeration blower by pressing the STOP button (figure 4, item 5) on the MSD control panel (figure 4, item 3).
4. Set to OFF the MSD DISCHARGE PUMP AND BLOWER circuit breaker (**LT 803 Only**), or the CONTROLLER FOR MSD DISCHARGE PUMP AND BLOWER circuit breaker (**All Other Vessels**) (figure 2, item 1) in the 440V power panel No. 4. Lock out and tag out (FM 55-502).
5. Set to OFF the SEWAGE DISCHARGE PUMP No. 1 circuit breaker (**LT 803 Only**), or the LVP FOR STARBOARD SEWAGE DISCHARGE PUMP No. 1 circuit breaker (**All Other Vessels**) (figure 5, item 1), and the SEWAGE DISCHARGE PUMP No. 2 circuit breaker (**LT 803 Only**), or the LVP FOR PORT SEWAGE DISCHARGE PUMP No. 2 circuit breaker (**All Other Vessels**) (figure 5, item 3) in the 440V power panel No. 1 (figure 5, item 2). Lock out and tag out (FM 55-502).
6. Align the valves for the MSD as specified in figure 3 and table 2.

END OF WORK PACKAGE

**OPERATOR, UNIT, DIRECT SUPPORT, AND GENERAL SUPPORT MAINTENANCE
MARINE SANITATION DEVICE FOR
INLAND AND COASTAL LARGE TUG (LT)
OPERATION UNDER UNUSUAL CONDITIONS**

INITIAL SETUP:

Personnel Required:

One Watercraft Engineer, 88L

Equipment Conditions:

All ventilation fans operating normally (TM 55-1925-273-10).

Ship's service air operating normally (TM 55-1925-273-10).

References:

TM 55-1925-273-10

WP 0005 00

SECURITY MEASURES FOR ELECTRONIC DATA

There are no required security measures for electronic data. The Marine Sanitation Device (MSD) components do not use or store any electronic data.

UNUSUAL ENVIRONMENT/WEATHER

There are no environmental or weather conditions that prevent the MSD from operating.

EMERGENCY PROCEDURES

NOTE

Emergencies constitute pipe leaks, personnel injury, or obvious equipment malfunction.

In the event of an emergency, press the STOP button (figure 1, item 1) on the MSD control panel (figure 1, item 2) and set to OFF the MSD DISCHARGE PUMP AND BLOWER circuit breaker (**LT 803 Only**), or the CONTROLLER FOR MSD DISCHARGE PUMP AND BLOWER circuit breaker (**All Other Vessels**) (figure 2, item 1) in 440V power panel No. 4.

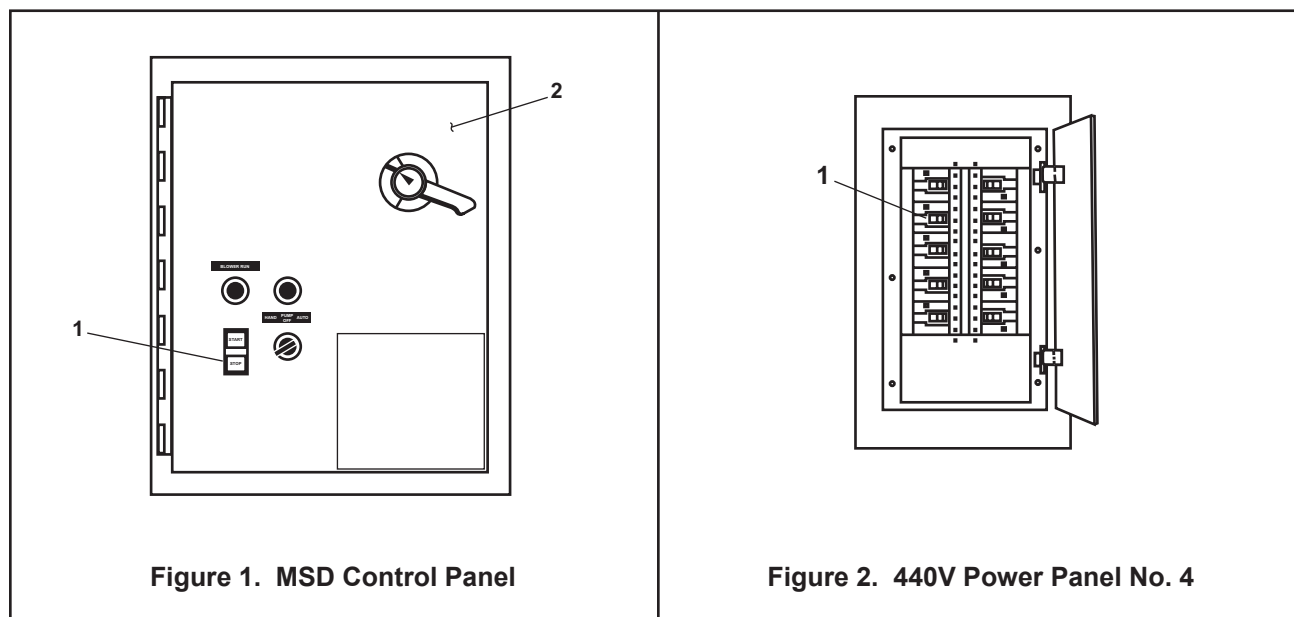

WATER CLOSET TO SEWAGE HOLDING TANK

1. Align the valves for the MSD to operate under unusual conditions as specified in figure 3 and table 1.
2. OPEN valve SD-3 SEWAGE DRAIN TO HOLDING TANK (figure 3, item 19).
3. Verify that valve SD-2 SEWAGE OVERBOARD DISCHARGE (figure 3, item 18) is CLOSED.
4. Verify that valve SD-1 SEWAGE INLET TO MSD (figure 3, item 17) is CLOSED.
5. Return the MSD to operation under usual conditions (WP 0005 00) as soon as the equipment malfunction has been corrected.

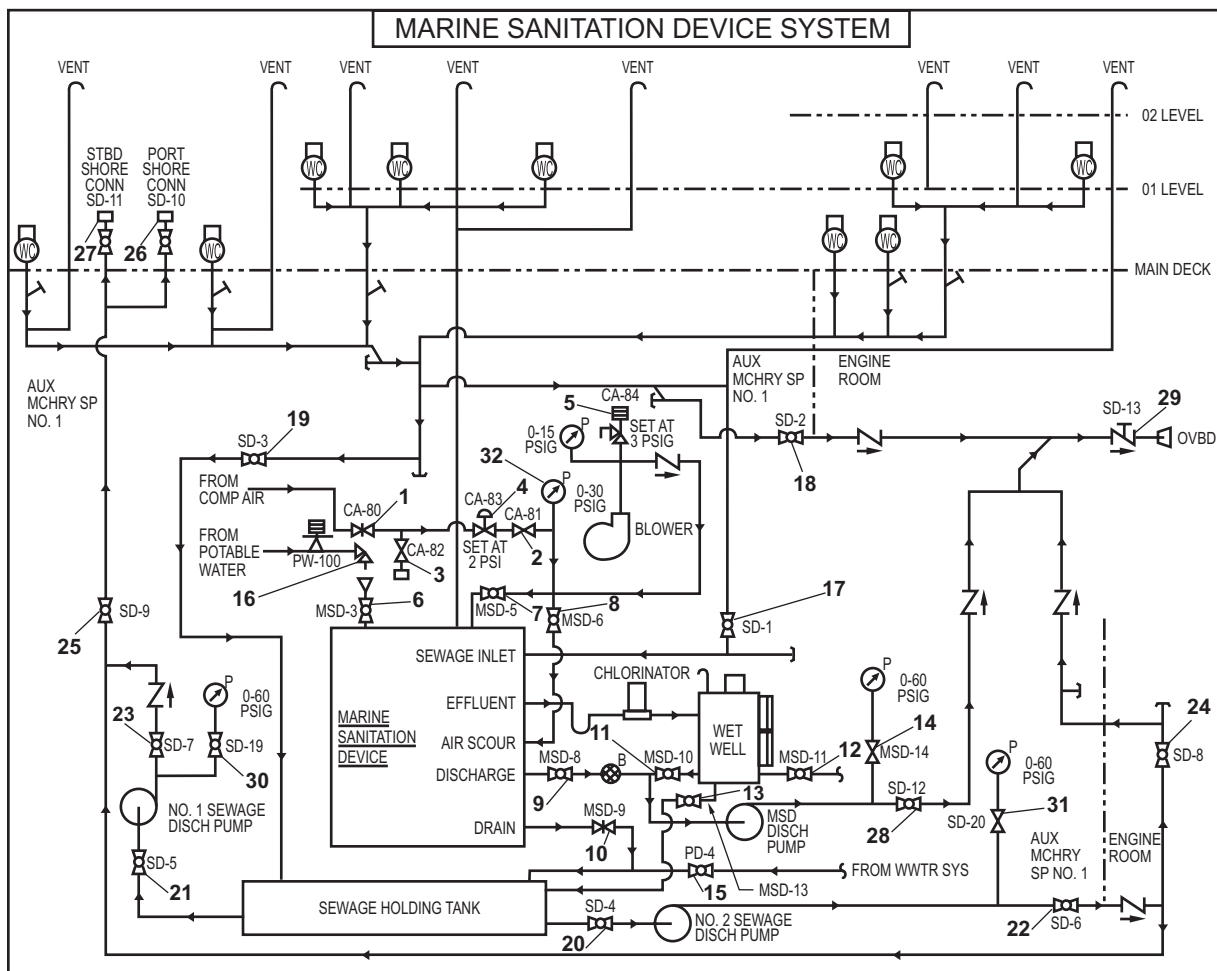

Figure 3. MSD Schematic

Table 1. Valve Alignment for MSD Operation Under Unusual Conditions

Item Number (Figure 3)	Valve Number	Function	Position During Operation Under Unusual Conditions
1	CA-80	COV-LP AIR	CLOSED
2	CA-81	COV-LP AIR	CLOSED
3	CA-82	LP AIR HOSE SHUTOFF	CLOSED
4	CA-83	PRV-SET AT 2 PSIG	Factory Set
5	CA-84	RV-SET AT 3 PSIG	Factory Set
6	MSD-3	POTW FILL TO MSD ISLN	CLOSED
7	MSD-5	BLOWER DISCHARGE SHUTOFF	CLOSED
8	MSD-6	BLOWER DISCH TO AIR SCOURING SOV	CLOSED
9	MSD-8	MEDIA TANK PUMP-OUT DR	CLOSED
10	MSD-9	MEDIA TANK DRAIN	CLOSED
11	MSD-10	WET WELL DISCHARGE	CLOSED
12	MSD-11	WET WELL SAMPLE	CLOSED
13	MSD-13	WET WELL DRAIN TO HOLDING TANK	CLOSED
14	MSD-14	MSD DISCH PUMP GAGE ISLN	CLOSED
15	PD-4	WASTE WTR TO SEW HLDG TANK	OPEN
16	PW-100	POTW ISOLATION	CLOSED
17	SD-1	SEWAGE INLET TO MSD	CLOSED
18	SD-2	SEWAGE OVERBOARD DISCHARGE	CLOSED
19	SD-3	SEWAGE DRAIN TO HOLDING TANK	CLOSED
20	SD-4	COV-SEW DISCH PMP NO. 2 SUCT	CLOSED
21	SD-5	COV-SEW DISCH PMP NO. 1 SUCT	CLOSED
22	SD-6	COV-SEW DISCH PMP NO. 2 DISCH	CLOSED
23	SD-7	COV-SEW DISCH PMP NO. 1 DISCH	CLOSED
24	SD-8	SEWAGE OVERBOARD DISCHARGE	CLOSED
25	SD-9	SEWAGE TO SHORE CONN	CLOSED
26	SD-10	SEWAGE SHORE CONN PORT	CLOSED

Table 1. Valve Alignment for MSD Operation Under Unusual Conditions (continued)

Item Number (Figure 3)	Valve Number	Function	Position During Operation Under Unusual Conditions
27	SD-11	SEWAGE SHORE CONN STBD	CLOSED
28	SD-12	MSD OVERBOARD DISCH PMP DISCH	CLOSED
29	SD-13	SEWAGE OVERBOARD DISCHARGE	CLOSED
30	SD-19	SEW PMP NO. 1 DISCH PRESS GAGE ISLN	CLOSED
31	SD-20	SEW PMP NO. 2 DISCH PRESS GAGE ISLN	CLOSED

WATER CLOSET DISCHARGE TO OVERBOARD**NOTE**

There are local, national, and international restrictions on when and where the MSD can be operated. Comply with federal, state, U.S. Coast Guard, and all other pollution discharge regulations.

1. Align the valves for the MSD to operate under unusual conditions as specified in figure 3 and table 1.
2. OPEN valve SD-2 SEWAGE OVERBOARD DISCHARGE (figure 3, item 18).
3. Verify that valve SD-3 SEWAGE DRAIN TO HOLDING TANK (figure 3, item 19) is CLOSED.

NOTE

With SD-2 SEWAGE OVERBOARD DISCHARGE and SD-13 SEWAGE OVERBOARD DISCHARGE valves OPEN, sewage will flow directly overboard, bypassing the sewage holding tank and the MSD.

4. OPEN SD-13 SEWAGE OVERBOARD DISCHARGE valve (figure 3, item 29).
5. Return the MSD to operation under usual conditions (WP 0005 00) as soon as the emergency or equipment failure has been corrected.

BLOWER FAILURE

1. Secure the blower by pressing the STOP button (figure 1, item 1) on the MSD control panel (figure 1, item 2) and set to OFF the MSD DISCHARGE PUMP AND BLOWER circuit breaker (**LT 803 Only**), or the CONTROLLER FOR MSD DISCHARGE PUMP AND BLOWER circuit breaker (**All Other Vessels**) (figure 2, item 1) in 440V power panel No. 4.
2. OPEN valves CA-80 COV-LP AIR (figure 3, item 1) and CA-81 LP AIR SHUTOFF (figure 3, item 2).
3. Verify that the pressure is between 0.5 and 3.0 PSI (0.03 and .21 bar) on the pressure gauge (figure 3, item 32).
4. Return the MSD to operation under usual conditions (WP 0005 00) as soon as the blower malfunction has been corrected.

END OF WORK PACKAGE

Chapter 3

Troubleshooting Procedures for Marine Sanitation Device

Inland and Coastal Large Tug (LT)

**OPERATOR AND UNIT MAINTENANCE
MARINE SANITATION DEVICE FOR
INLAND AND COASTAL LARGE TUG (LT)
TROUBLESHOOTING INDEX**

USE OF THE INDEX

Troubleshooting begins by identifying the equipment and the malfunction. Table 1 contains the operator troubleshooting procedures, and table 2 contains the unit troubleshooting procedures. The equipment list is contained in the left column of the tables, and the malfunctions are listed in the center column of the tables. Once the correct equipment and malfunction are located, look immediately to the right for the work package and procedure that correspond to the malfunction. After locating the appropriate work package and procedure, turn to that procedure, and follow the instructions in the paragraph that follows.

USE OF TROUBLESHOOTING PROCEDURES

Functional flow logic tree troubleshooting procedures are used for all troubleshooting procedures in this manual. In this troubleshooting style, a pill shaped symbol (figure 1) is used to depict the beginning or end point of a procedure. Decision points are depicted by diamond shaped symbols (figure 2). Action points, as well as warnings, cautions, and notes are contained in rectangular symbols (figure 3). Procedures that are too large for one page are joined together by the circular shaped connector symbols (figure 4). The connector symbol will denote which page and step to go to (or come from) on another page. Finally, when flowchart lines cross, the technician must ensure that the correct path is followed. Crossing lines (figure 5) indicate that the points connect. Lines that cross with a jump symbol in the center (figure 6) indicate that the points do not connect. The technician must correctly follow the arrows to complete the troubleshooting procedure.

Look for the pill shaped beginning symbol in the upper left corner of the procedure. This symbol should contain the identified malfunction or symptom. Starting from this point, follow the arrowed lines through the procedure. Remember that the diamond shaped symbols denote a decision step. At each of these points you will be required to make a decision and to follow the appropriate line for that decision. Continue to follow the arrowed lines through the procedure until the malfunction or symptom is corrected.



Figure 1. Pill Shaped Symbol

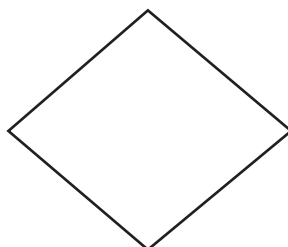

Figure 2. Diamond Shaped Symbol



Figure 3. Rectangle Shaped Symbol



Figure 4. Circular Shaped Symbol

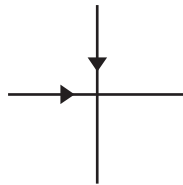

Figure 5. Crossed Lines Are Connected

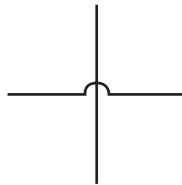

Figure 6. Crossed Lines Are Not Connected

Table 1. Operator Troubleshooting Procedures

Equipment	Malfunction	Work Package, Procedure
MSD	MSD does not function correctly	WP 0008 00, Procedure 1

Table 2. Unit Troubleshooting Procedures

Equipment	Malfunction	Work Package, Procedure
MSD	Foam from media tank vent	WP 0009 00, Procedure 5
	High water level in media tank	WP 0009 00, Procedure 6
	Odor in AMS 1	WP 0009 00, Procedure 2
	Odor in spaces other than AMS 1	WP 0009 00, Procedure 3
	Odor from the media tank vent	WP 0009 00, Procedure 1
	Poor drainage (toilets do not flush properly)	WP 0009 00, Procedure 4
	Poor effluent quality	WP 0009 00, Procedure 8
	Water spilling out of wet well	WP 0009 00, Procedure 7

END OF WORK PACKAGE

**OPERATOR MAINTENANCE
MARINE SANITATION DEVICE FOR
INLAND AND COASTAL LARGE TUG (LT)
OPERATOR TROUBLESHOOTING PROCEDURES**

INITIAL SETUP:

Personnel Required:

One Watercraft Engineer, 88L

References:

WP 0005 00

WP 0006 00

INTRODUCTION

The work package contains the following operator troubleshooting procedures:

<u>Malfunction/Symptom</u>	<u>Procedure</u>
MSD Does Not Function Correctly	1

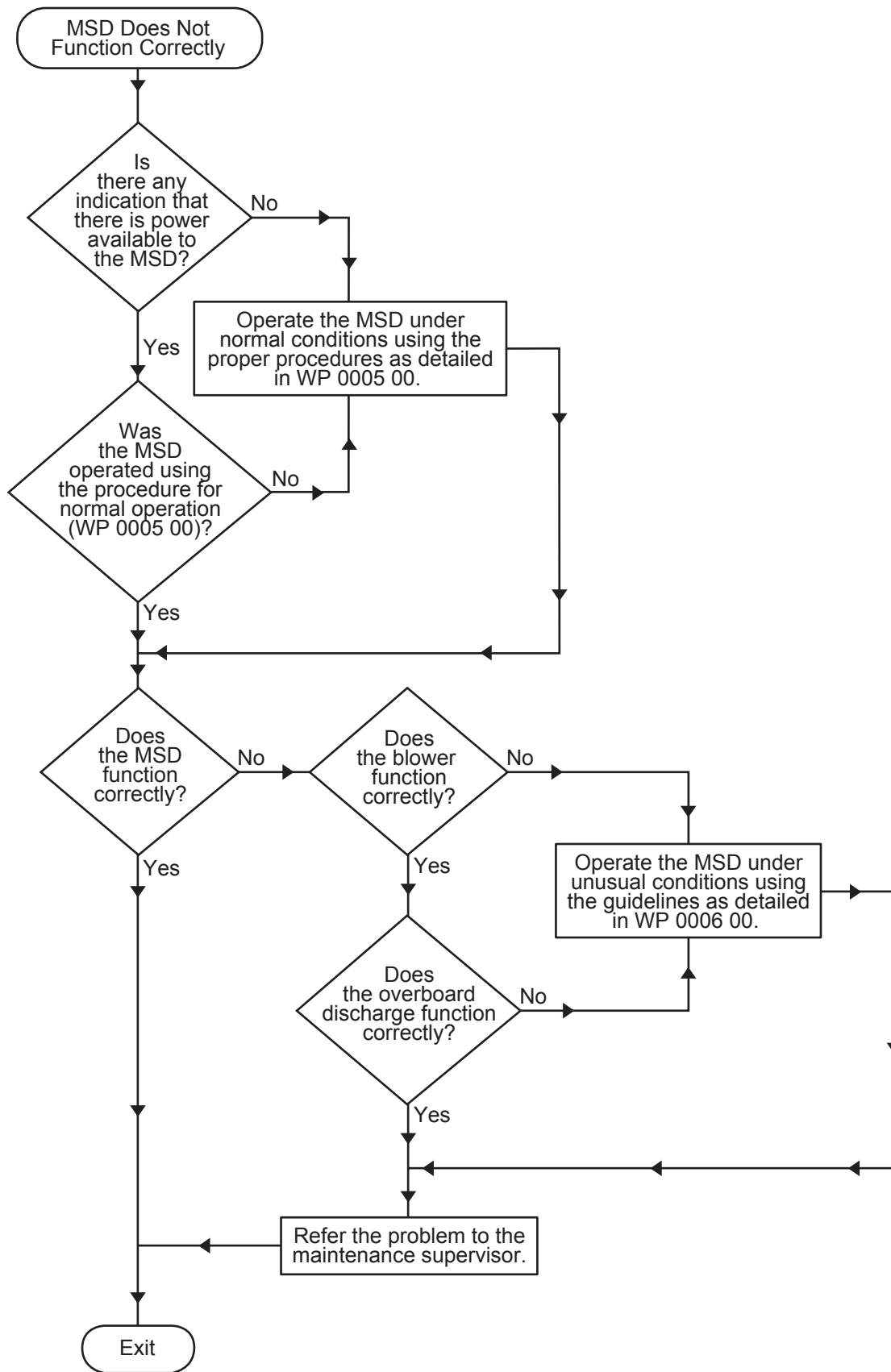

Procedure 1. MSD Does Not Function Correctly

END OF WORK PACKAGE

**UNIT MAINTENANCE
MARINE SANITATION DEVICE FOR
INLAND AND COASTAL LARGE TUG (LT)
UNIT TROUBLESHOOTING PROCEDURES**

INITIAL SETUP:

Tools and Special Tools:

- Tool Kit, General Mechanic's (Item 1, Table 2, WP 0035 00)
- Tool Kit, Electrician's (Item 2, Table 2, WP 0035 00)
- Multimeter (Item 4, Table 2, WP 0035 00)

References:

- WP 0005 00
- WP 0006 00
- WP 0013 00
- WP 0014 00
- WP 0016 00
- WP 0018 00
- WP 0025 00
- WP 0035 00

Materials/Parts:

- Vegetable Oil (from galley)

Personnel Required:

- Two Watercraft Engineers, 88L

INTRODUCTION

The following troubleshooting procedures are included in this work package:

<u>Malfunction/Symptom</u>	<u>Procedure</u>
Odor From The Media Tank Vent	1
Odor In AMS 1	2
Odor In Spaces Other Than AMS 1	3
Poor Drainage (Toilets Do Not Flush Properly)	4
Foam From Media Tank Vent	5
High Water Level In Media Tank	6
Water Spilling Out Of Wet Well	7
Poor Effluent Quality	8

TROUBLESHOOTING PROCEDURES

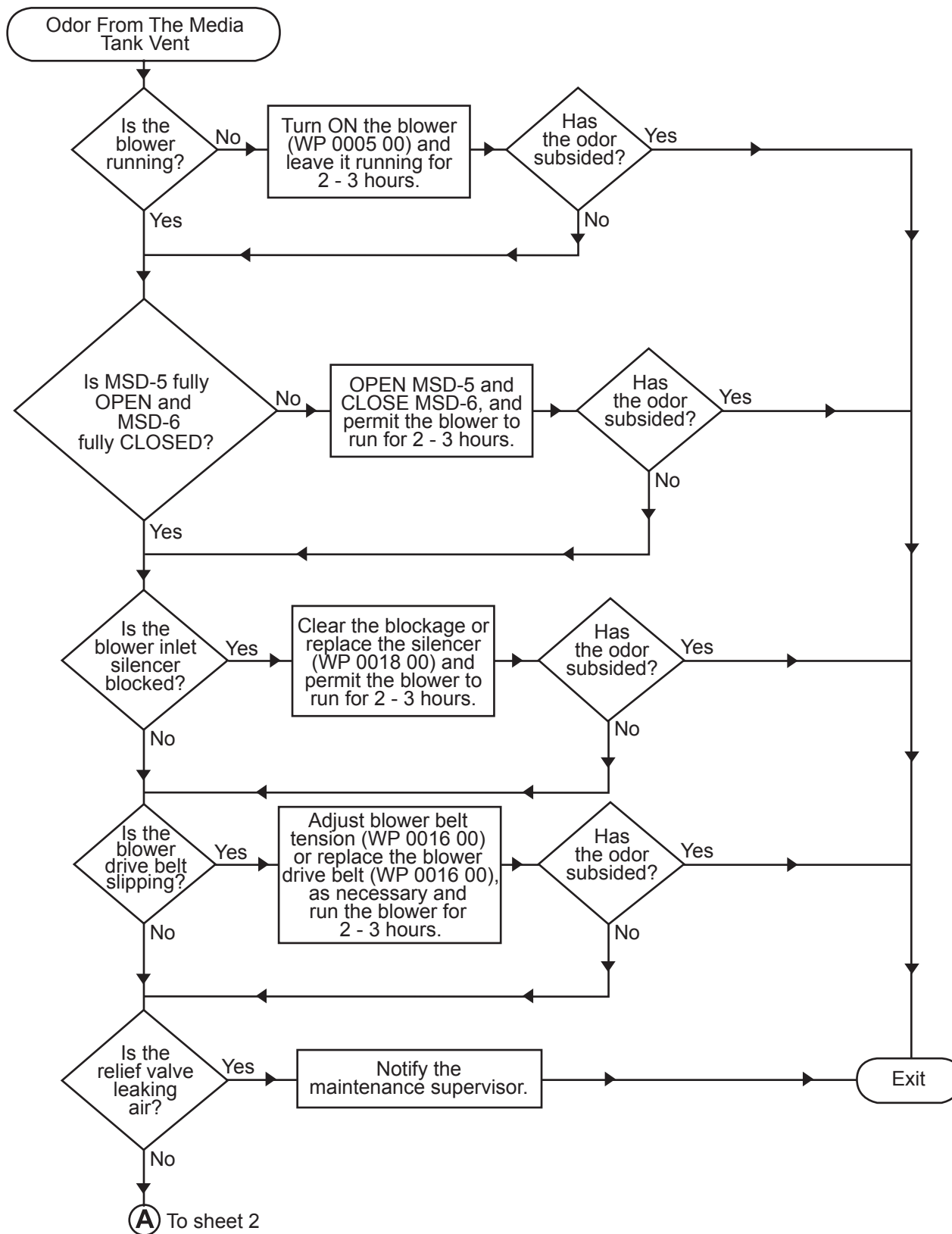

Procedure 1. Odor From The Media Tank Vent (Sheet 1 of 2)

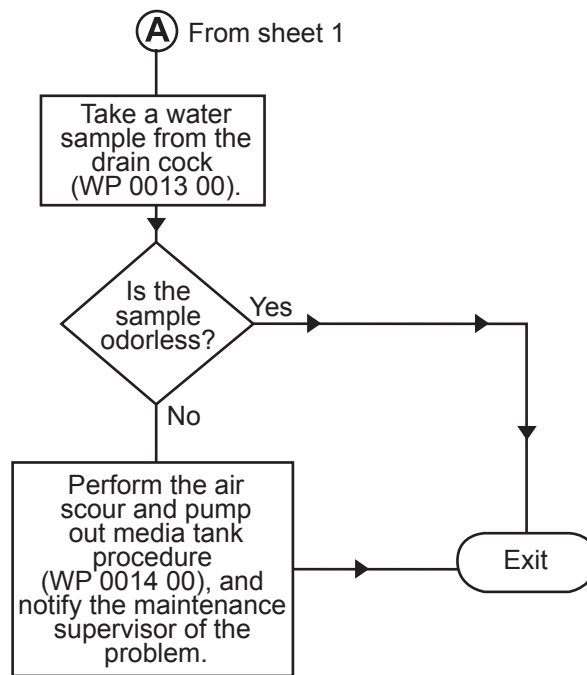

Procedure 1. Odor From The Media Tank Vent (Sheet 2 of 2)

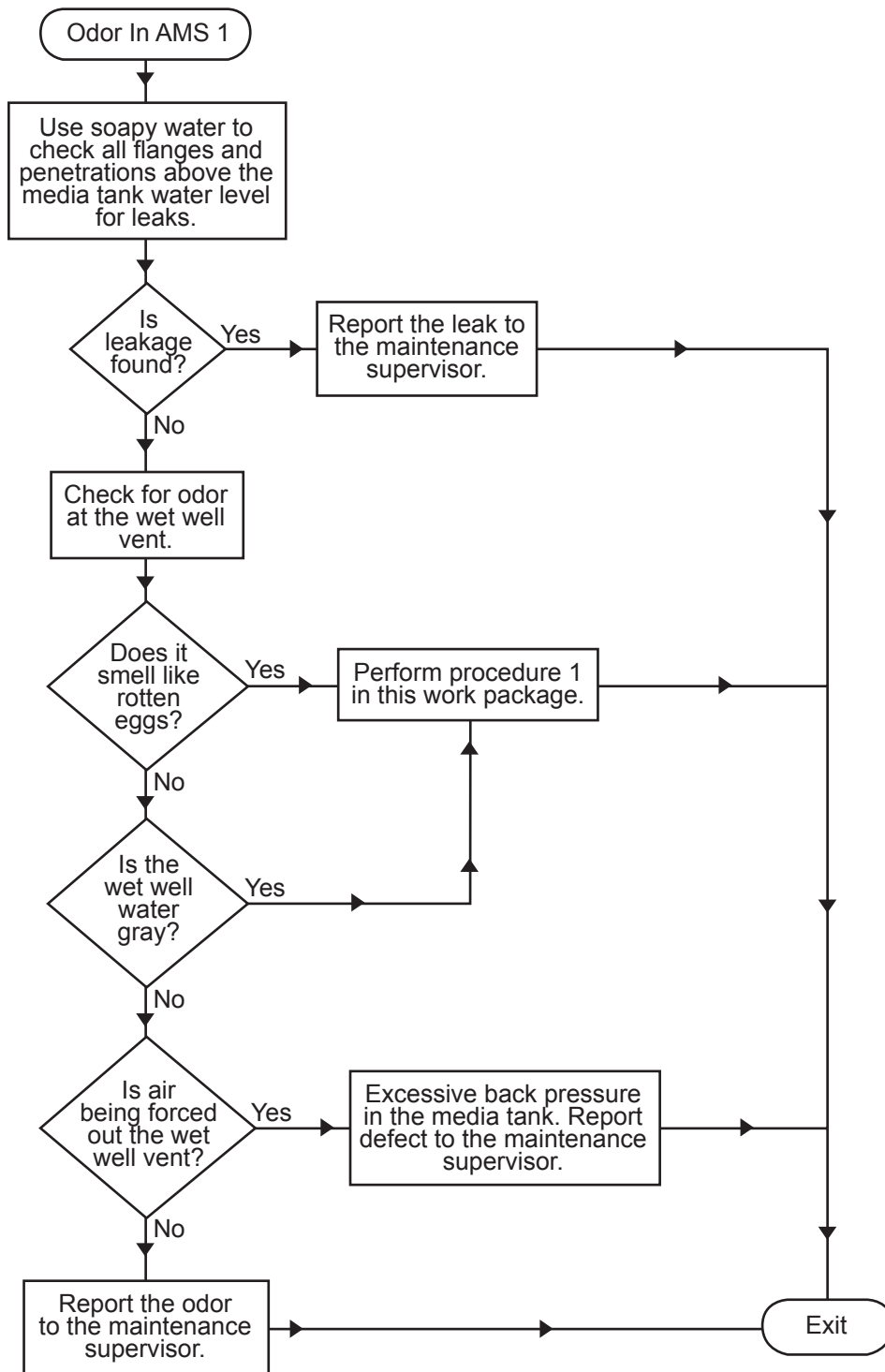

Procedure 2. Odor In AMS 1

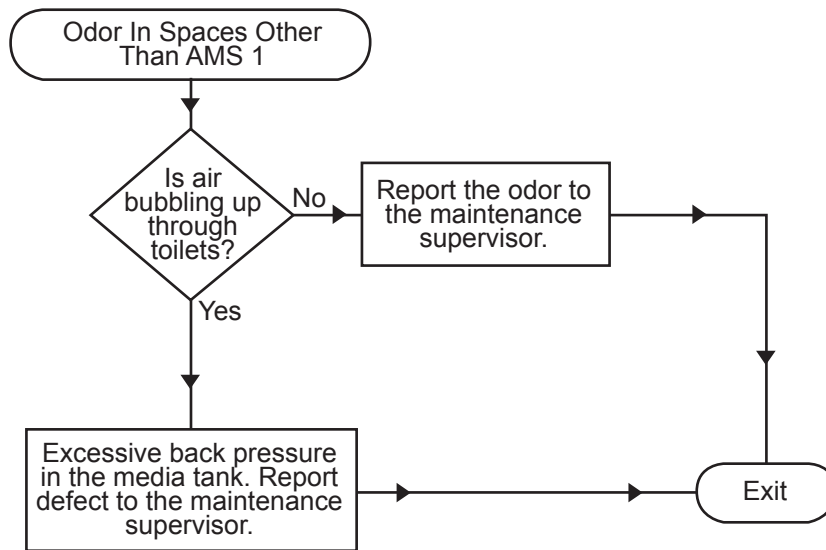

Procedure 3. Odor In Spaces Other Than AMS 1

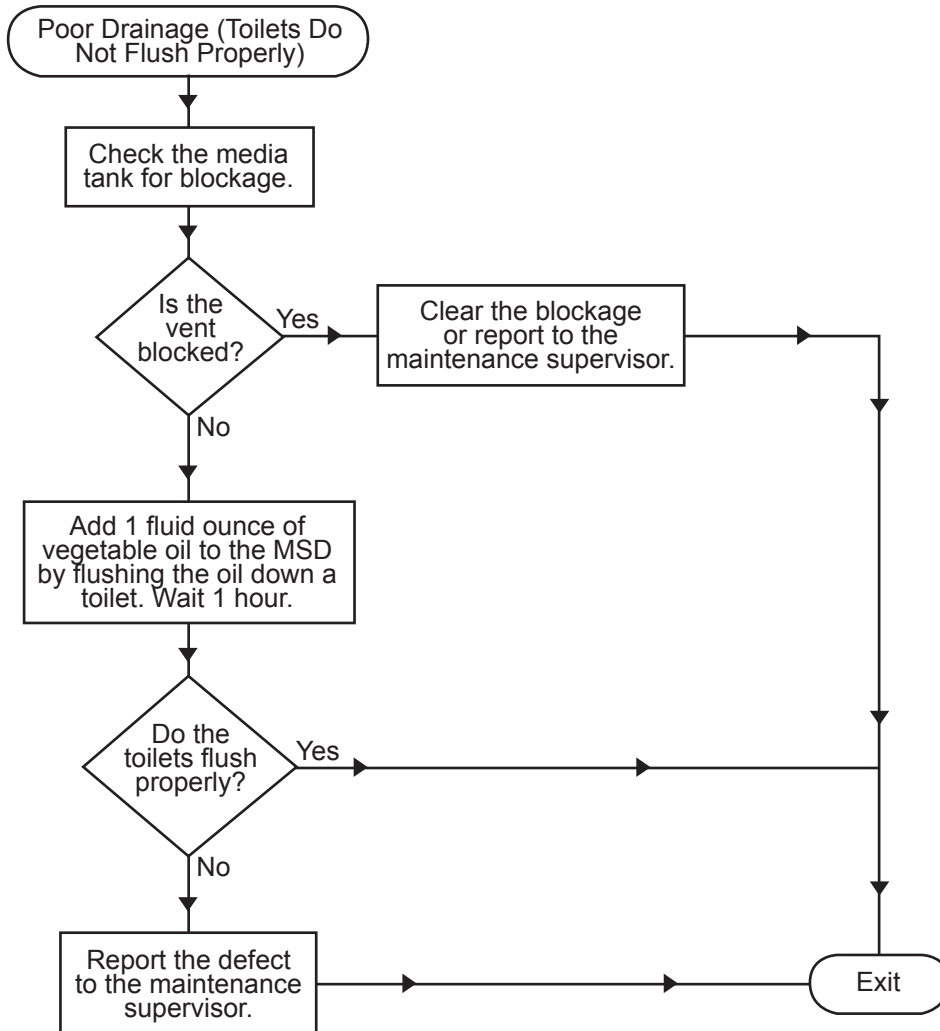

Procedure 4. Poor Drainage (Toilets Do Not Flush Properly)

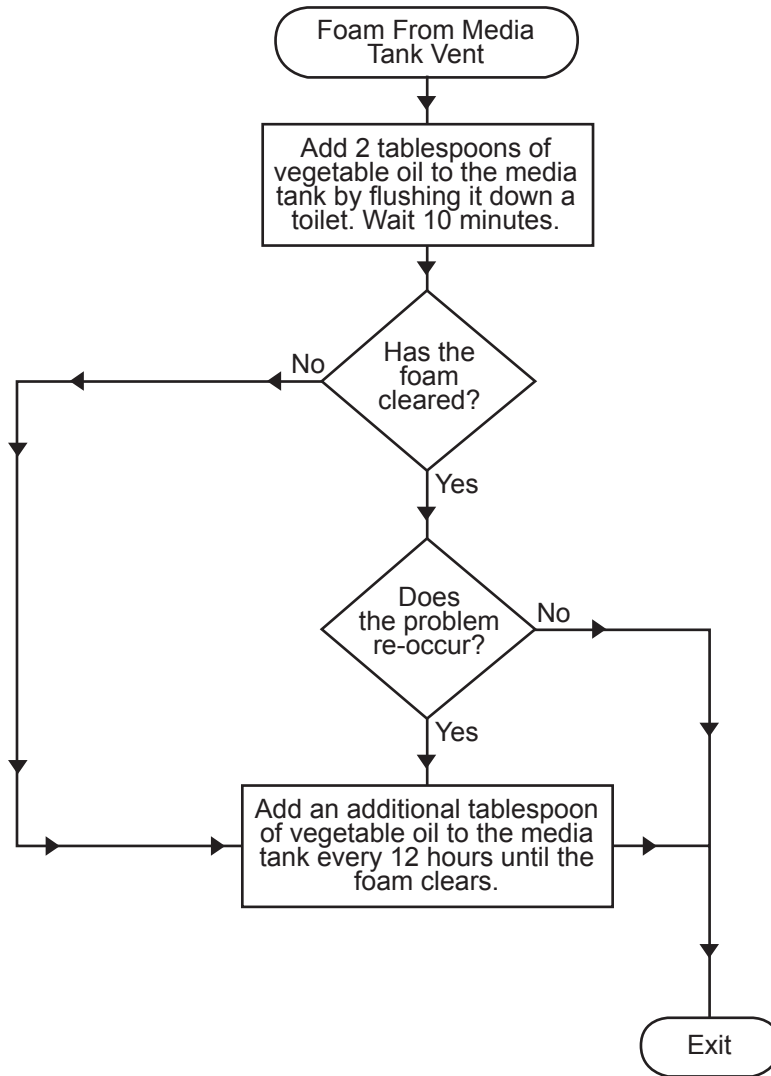

Procedure 5. Foam From Media Tank Vent

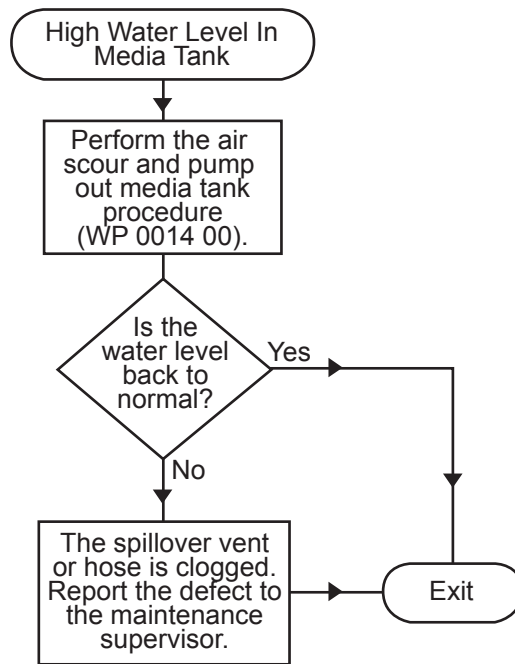

Procedure 6. High Water Level In Media Tank

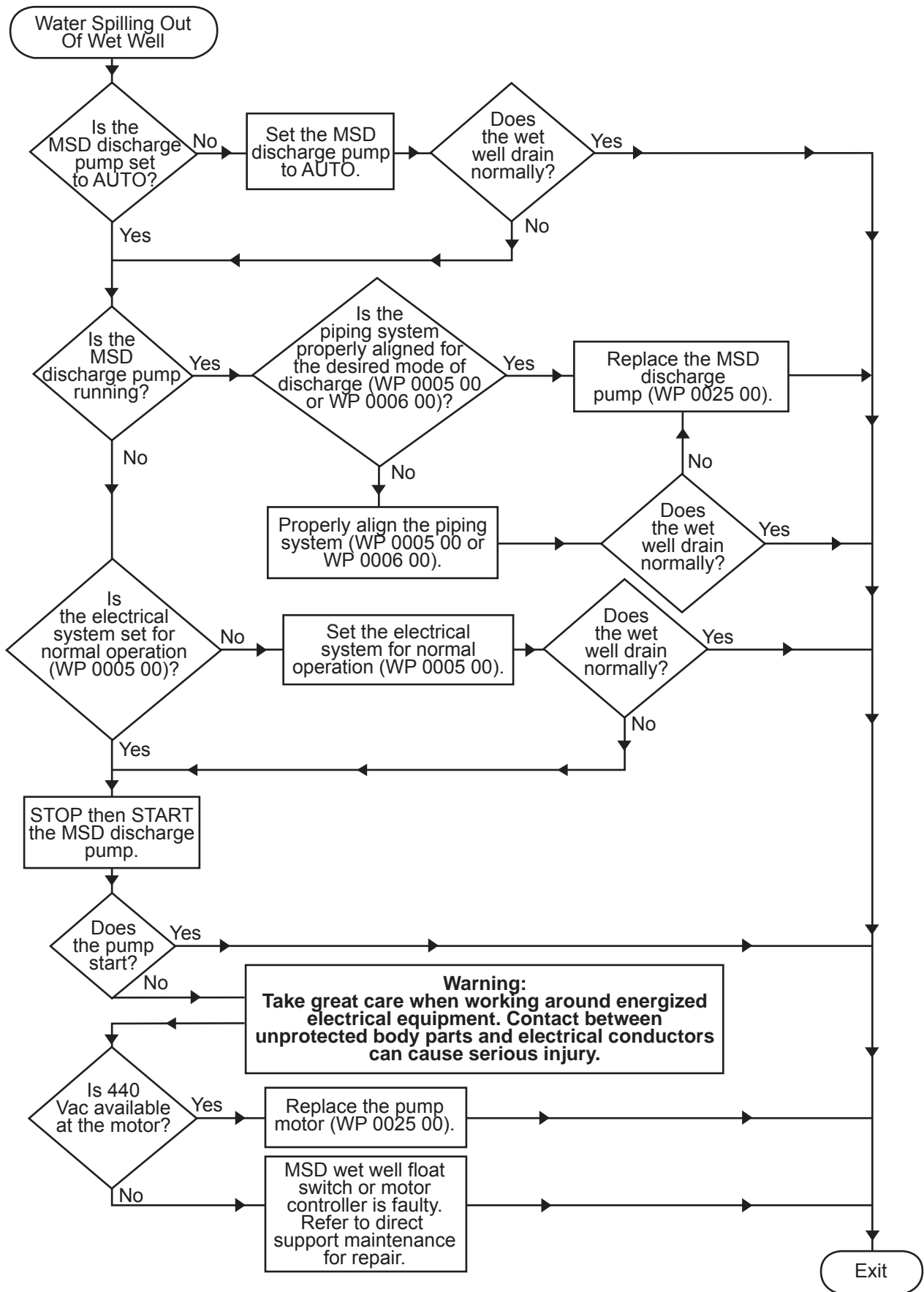

Procedure 7. Water Spilling Out Of Wet Well

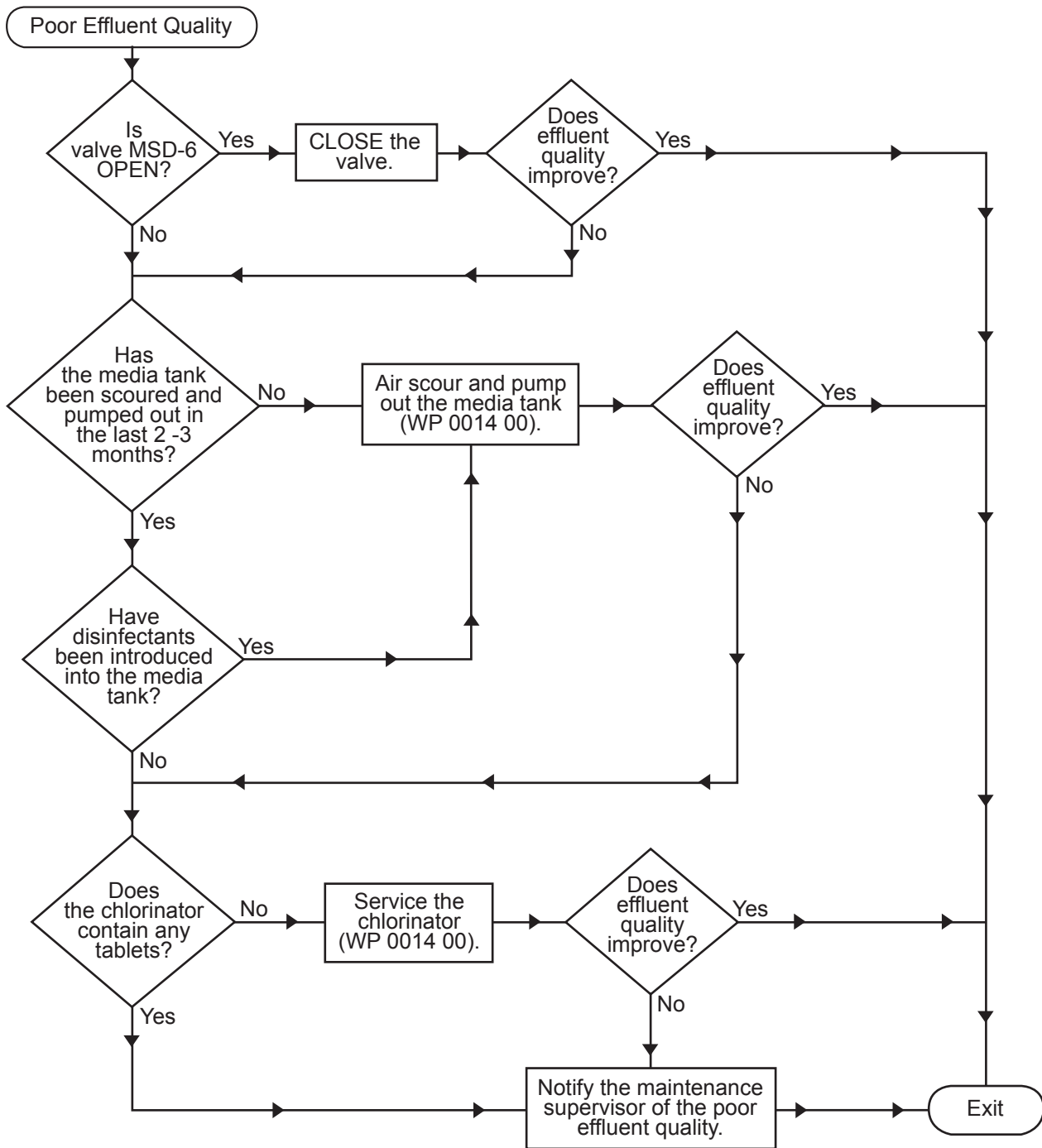

Procedure 8. Poor Effluent Quality

END OF WORK PACKAGE

Chapter 4

Maintenance Instructions for Marine Sanitation Device

Inland and Coastal Large Tug (LT)

**OPERATOR AND UNIT MAINTENANCE
MARINE SANITATION DEVICE FOR
INLAND AND COASTAL LARGE TUG (LT)
SERVICE UPON RECEIPT AND PREPARATION FOR STORAGE**

INITIAL SETUP:**Personnel Required:**

One Watercraft Engineer, 88L

References:

TB 740-97-4

WP 0012 00

SERVICE UPON RECEIPT**SHELTER REQUIREMENTS**

The Marine Sanitation Device (MSD) is installed in AMS 1, out of the weather. Despite this, the MSD and its components can still become wet during compartment cleaning or during service of other systems such as potable water piping. If there is a possibility that the electrical components could become wet due to cleaning or equipment maintenance operations, secure the MSD and its components and cover them with waterproof tarps until cleaning or maintenance is complete.

PRELIMINARY SERVICING OF EQUIPMENT AND PRELIMINARY CHECKS AND ADJUSTMENTS OF EQUIPMENT

Perform all operator Preventative Maintenance Checks and Services (PMCS) up through, and including, the semiannual level. Operator PMCS procedures are contained in WP 0012 00. There is no unit PMCS for the MSD.

PREPARATION FOR STORAGE OR SHIPMENT

The MSD is prepared for storage or shipment along with the remainder of the Large Tug (LT). Complete instructions for this preparation are contained in TB 740-97-4, Preservation of Vessels for Storage.

END OF WORK PACKAGE

**OPERATOR MAINTENANCE
MARINE SANITATION DEVICE FOR
INLAND AND COASTAL LARGE TUG (LT)
PMCS INTRODUCTION**

PURPOSE AND USE OF PREVENTIVE MAINTENANCE CHECKS AND SERVICES (PMCS) DATA

PMCS is performed to keep the Marine Sanitation Device (MSD) in operating condition. The checks are used to find, correct, and report problems so that defects may be discovered and corrected. PMCS is to be accomplished each day the marine sanitation device is operated, using the appropriate work packages. Pay attention to all WARNINGS, CAUTIONS, and NOTES that precede individual steps. WARNINGS indicate possible danger to personnel. CAUTIONS indicate possible damage to equipment. NOTES are for clarification and additional information. An explanation is prepared for each PMCS check entry, and for any general checks and services common to an entire piece of equipment or system. An explanation of PMCS chart columns follows:

ITEM NUMBER COLUMN

The checks and services are numbered within a specific work package in chronological order.

INTERVAL

This column indicates the periodicity of the check or service.

1. Prior to operating the Marine Sanitation Device (MSD), do Before PMCS.
2. During MSD operation, do During PMCS.
3. Once a week do Weekly PMCS.
4. Do Monthly PMCS once a month. If equipment has not been operated in a month, also do During PMCS at the same time as Monthly PMCS.
5. Do Quarterly PMCS once a quarter. If the equipment has not been operated in a quarter, also do After PMCS at the same time as Quarterly PMCS.
6. Do Semiannual PMCS once every six months. If the equipment has not been operated within the last six months, also do the Monthly PMCS at the same time as Semiannual PMCS.
7. If a deficiency is noted when performing PMCS, fix it, if possible, using troubleshooting procedures and/or maintenance procedures. If the deficiency cannot be corrected, write up the items not fixed on DA Form 2404 Equipment Inspection, for unit maintenance. For further information on how to use this form, see DA PAM 738-750.

MANHOUR

This column indicates the projected amount of time that is expected to take to complete the check or service. Checks and services that require additional personnel include a cumulative amount of time.

ITEM TO BE CHECKED OR SERVICED

This column lists the equipment or item to be checked or serviced.

PROCEDURE COLUMN

This column contains a brief description of how to perform the checks and services, or it contains the reference to the work package or technical manual that contains the procedural information. Carefully follow the instruc-

tions. If the necessary tools are not available, or if the procedure indicates, have organizational maintenance do the work.

EQUIPMENT NOT READY/AVAILABLE IF

This column lists the criteria that will limit the use of equipment or make it not ready for use. Depending on the severity of the limitation, the MSD may not be able to operate and perform its primary mission. The terms "ready/available" and "mission capable" refer to the same status: Equipment is on hand and can perform its combat mission. If tools required to perform PMCS are not listed in the work package, notify unit maintenance. Write up items not fixed on DA Form 2404 for unit maintenance. For further information on how to use this form, see DA PAM 738-750.

DOCUMENTATION OF PMCS ITEM FAILURES

PMCS item failures are to be recorded on DA Form 2404, Equipment Inspection and Maintenance Worksheet, and forwarded to unit maintenance via the vessel's chief engineer. Documentation of PMCS item failures must include the compartment location and item number within the work package to ensure proper dissemination. All corrected faults will be recorded on DA Form 4640 (Harbor Boat Deck Department Log for Class A&B Vessels) and DA Form 4993 (Harbor Boat Engine Department Log for Class A and C-1 Vessels). All uncorrected faults will be transcribed to a DA Form 2407, Maintenance Request, and the appropriate log entry must be made. The crew will service the LT as outlined by the intervals contained in the PMCS tables.

CORROSION PREVENTION AND CONTROL (CPC)

Corrosion Prevention and Control (CPC) of Army materiel is a continuing concern. It is important that any corrosion problems be reported so that they can be corrected and improvements made to prevent future problems. Corrosion is typically associated with rusting of metals, but it can also include deterioration of other materials, such as rubber and plastic. Unusual cracking, softening, swelling, or breaking of materials may indicate a corrosion problem. Suspected corrosion problems should be reported using SF 368 (Product Quality Deficiency Report). Use of key words such as "corrosion," "rust," "deterioration," or "cracking" will ensure that the information is identified as a CPC problem.

LEAKAGE DEFINITION

CAUTION

Equipment operation is allowable with minor leakages (Class I or II) except for fuel leaks. Of course, consideration must be given to the fluid capacity of the item or system being checked. When in doubt, ask your supervisor.

When operating with Class I or II leaks, continue to check fluid levels as required in your PMCS. Class III leaks should be reported immediately to your supervisor. It is necessary to know how fluid leakage affects the status of the MSD. The following are definitions of the classes of leakage an operator or crewmember needs to know to be able to determine the condition of the leak. Learn and then be familiar with them. When in doubt, ask your supervisor.

LEAKAGE CLASSIFICATIONS I, II, III

Leakage classifications. Leakage definitions for operator/crew PMCS shall be classified as follows:

1. Class I: Seepage of fluid (as indicated by wetness or discoloration) not great enough to form drops.
2. Class II: Leakage of fluid great enough to form drops but not enough to cause drops to drip from the item being checked/inspected.
3. Class III: Leakage of fluid great enough to form drops that fall from the item being checked/inspected.

INSPECTION

Look for signs of a problem or trouble. Senses help here. You can feel, smell, hear, or see many problems. Be alert when on the vessel. Inspect to see if items are in good condition. Are they correctly assembled, stowed, secured, excessively worn, leaking, corroded, or properly lubricated? Correct any problems found or notify unit maintenance. There are some common items to check all over the MSD. These include the following:

1. Bolts, clamps, nuts, and screws: Continuously check for looseness. Look for chipped paint, bare metal, rust, or corrosion around bolt and screw heads and nuts. Tighten them when you find them loose. If tools are not available, notify unit maintenance.
2. Welds: Many items on the MSD are welded. To check these welds, look for chipped paint, rust, corrosion, or gaps. When these conditions exist, notify unit maintenance on DA Form 2404.
3. Electrical wires, connectors, and harnesses: Tighten loose connectors. Look for cracked or broken insulation, bare wires, and broken connectors. If any are found, notify unit maintenance.
4. Hoses and fluid lines: Look for wear, damage, and leaks, and make sure clamps and fittings are tight. Wet spots mean a leak. A stain by a fitting or connector can also mean a leak. When you find a leak, notify unit maintenance.

GENERAL STATEMENT OF LUBRICATION REQUIREMENTS

Any lubricants called out by PMCS in this manual are identified by standard military symbols (MIL-HDBK-113 and MIL-HDBK-275).

LUBRICATION SERVICE INTERVALS - NORMAL CONDITIONS

For safer, more trouble free operations, make sure that the MSD is serviced when required. For the proper lubrication and service intervals, refer to WP 0012 00.

LUBRICATION SERVICE INTERVALS - UNUSUAL CONDITIONS

The MSD may require extra service and care when it is operated under unusual conditions. High or low temperatures, long periods of hard use, or continued use in a dirty environment will break down the lubricants and fluids, requiring more frequent service.

LUBRICATION UNIVERSALS

1. Always clean fittings before lubricating them. Failure to do so can force contaminants into the bearing.
2. Always use the PMCS work packages as the guide for lubrication.
3. Never use the wrong type/grade of lubricant.
4. Never use too much lubricant.

END OF WORK PACKAGE

**OPERATOR MAINTENANCE
MARINE SANITATION DEVICE FOR
INLAND AND COASTAL LARGE TUG (LT)
OPERATOR PREVENTIVE MAINTENANCE CHECKS AND SERVICES INCLUDING LUBRICATION**

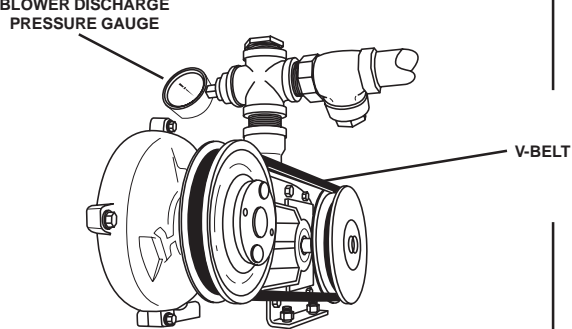
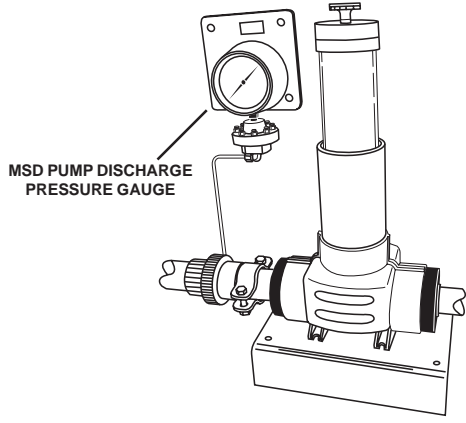
ITEM NO.	INTERVAL	MAN-HOUR	ITEM TO BE CHECKED OR SERVICED	PROCEDURE	EQUIPMENT NOT READY/ AVAILABLE IF:
1	Before	0.2	V-Belt	Inspect V-belt for serviceability. Check tension (WP 0016 00) and adjust if necessary.	
2	Before	0.5	Chlorinator	Check the tablets in the chlorinator. 5 to 10 tablets should be present at all times. Add tablets as necessary (WP 0014 00).	
3	During	0.1	Blower Discharge Pressure Gauge	Check and record reading. Reading should be between 1.0 and 3.0 PSI (0.07 and 0.21 bar).	Reading is out of the target range. Gauge is missing or inoperative.
					
4	During	0.1	MSD Pump Discharge Pressure Gauge	Check the reading. Reading should be at least 5 PSI (0.34 bar) during pump operation.	Gauge is missing or inoperative.
					

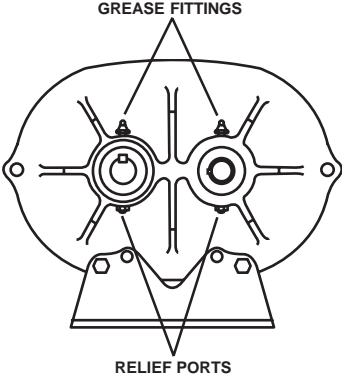
ITEM NO.	INTERVAL	MAN-HOUR	ITEM TO BE CHECKED OR SERVICED	PROCEDURE	EQUIPMENT NOT READY/ AVAILABLE IF:
5	Weekly	0.2	Effluent Water	Visually inspect the effluent water in the wet well. Water should be clear and free of particulate. If not, perform the residual chlorine test (WP 0014 00).	
6	Weekly	0.5	Chlorinator	Check the tablets in the chlorinator. 5 to 10 tablets should be present at all times. Add tablets as necessary (WP 0014 00).	
7	Weekly	0.2	Blower	<p>Apply general purpose grease (item 2, table 1, WP 0039 00) at each of the two zerk fittings on the blower until old grease exits the relief ports.</p>  <p>The diagram shows a top-down view of a blower motor head. It features two central zerk fittings labeled 'GREASE FITTINGS' with arrows pointing to them. Below the motor head, there are two relief ports labeled 'RELIEF PORTS' with arrows pointing to them. The motor head has a complex internal structure with various ports and connections.</p>	
8	Monthly	0.3	Effluent Water	Perform the residual chlorine test (WP 0014 00).	
9	Monthly	0.3	Media Tank, Chlorinator, Piping	Check the media tank, piping, wet well, chlorinator, valves, and discharge pump for leakage and proper operation.	Class III leakage.
10	Monthly	0.5	Wet Well	Clean the wet well inlet strainer (WP 0014 00).	
11	Quarterly	1.0	Media Tank	Perform air scour and pump out of media tank (WP 0014 00).	
12	Quarterly	0.3	Blower	Change the blower oil (WP 0017 00).	

END OF WORK PACKAGE

Chapter 5

Operator Maintenance Instructions for Marine Sanitation Device

Inland and Coastal Large Tug (LT)

**OPERATOR MAINTENANCE
MARINE SANITATION DEVICE FOR
INLAND AND COASTAL LARGE TUG (LT)
MARINE SANITATION DEVICE, ADJUST**

INITIAL SETUP:**Tools and Special Tools:**

Tool Kit, General Mechanic's (Item 1, Table 2, WP 0035 00)
 Test Kit, Sanitizer (Item 6, Table 2, WP 0035 00)
 Suitable Drain Pan
 Suitable Sample Bottle

Personnel Required:

One Watercraft Engineer, 88L

References:

TM 55-1925-273-10
 WP 0014 00
 WP 0035 00
 WP 0038 00

Materials/Parts:

Gloves, Chemical and Oil Protective (Item 1, Table 3, WP 0038 00)
 Goggles, Industrial (Item 2, Table 3, WP 0038 00)

Equipment Conditions:

All ventilation fans operating normally (TM 55-1925-273-10).

DISCHARGE SAMPLING

1. Place a suitable drain pan under the WET WELL SAMPLE valve MSD-11 (figure 1, item 1).

WARNING



Sewage is a common mode of transmission for parasitic organisms that may have the capability of causing communicable diseases. After coming in contact with sewage or contaminated equipment, be sure to clean yourself with a disinfectant soap. Avoid sewage contact with skin abrasions, punctures, cuts, and other open wounds. Wipe up and clean any spills and/or contaminated equipment using a disinfectant soap. Failure to comply can lead to serious illness.

2. OPEN and CLOSE the WET WELL SAMPLE valve MSD-11 (figure 1, item 1) to flush any contaminants out of the valve.
3. Fill a suitable sample bottle with effluent from the WET WELL SAMPLE valve MSD-11 (figure 1, item 1). Let the sample settle for about 15 minutes.

NOTE

A small amount of solids at the bottom of the sample bottle is not uncommon.

4. Check the effluent for color and odor and perform a residual chlorine test (WP 0014 00).
5. If the effluent sample is gray or smells like rotten eggs, perform the air scour and pump out procedure (WP 0014 00).

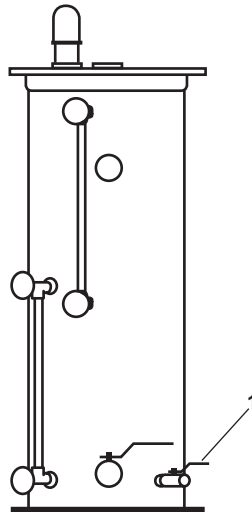

Figure 1. MSD Wet Well

6. If the residual chlorine test requires chlorine adjustment, perform the chlorinator feed tube adjustment procedure in this work package.

CHLORINATOR FEED TUBE ADJUSTMENT

NOTE

The chlorinator can be adjusted while online.

1. To provide the maximum chemical dose, fully insert the feed tube (figure 2, item 1) into the body (figure 2, item 2) until it locks into position between the ribs in the flow deck (figure 2, item 3).
2. To reduce the chemical dose, rotate the feed tube (figure 2, item 1) clockwise 1/4 of a turn. Rotating the feed tube raises the tube approximately 1/8" and reduces the chemical dose.

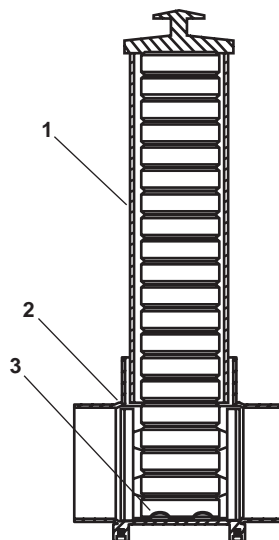

Figure 2. Chlorinator Adjustment

END OF WORK PACKAGE

**OPERATOR MAINTENANCE
MARINE SANITATION DEVICE FOR
INLAND AND COASTAL LARGE TUG (LT)
MARINE SANITATION DEVICE, SERVICE**

INITIAL SETUP:**Tools and Special Tools:**

Tool Kit, General Mechanic's (Item 1, Table 2, WP 0035 00)
 Test Kit, Sanitizer (Item 6, Table 2, WP 0035 00)
 Suitable Sample Bottle
 Suitable Drain Pan

Materials/Parts:

Gloves, Chemical and Oil Protective (Item 1, Table 3, WP 0038 00)
 Goggles, Industrial (Item 2, Table 3, WP 0038)
 Respirator (Item 6, Table 3, WP 0038 00)
 Silicone Compound (Item 6, Table 1 WP 0039 00)
 Tag, Danger (Item 7, Table 1, WP 0039 00)

Personnel Required:

Two Watercraft Engineers, 88L

References:

FM 55-502
 TM 55-1925-273-10
 WP 0005 00
 WP 0013 00
 WP 0035 00
 WP 0038 00
 WP 0039 00

Equipment Conditions:

All ventilation fans operating normally (TM 55-1925-273-10)

RESIDUAL CHLORINE TEST

1. Place a suitable drain pan under the WET WELL SAMPLE valve MSD-11 (figure 1, item 1).



Sewage is a common mode of transmission for parasitic organisms that may have the capability of causing communicable diseases. After coming in contact with sewage or contaminated equipment, be sure to clean yourself with a disinfectant soap. Avoid sewage contact with skin abrasions, punctures, cuts, and other open wounds. Wipe up and clean any spills and/or contaminated equipment using a disinfectant soap. Failure to comply can lead to serious illness.

2. OPEN and CLOSE the WET WELL SAMPLE valve MSD-11 (figure 1, item 1) to remove any contaminants from the piping.

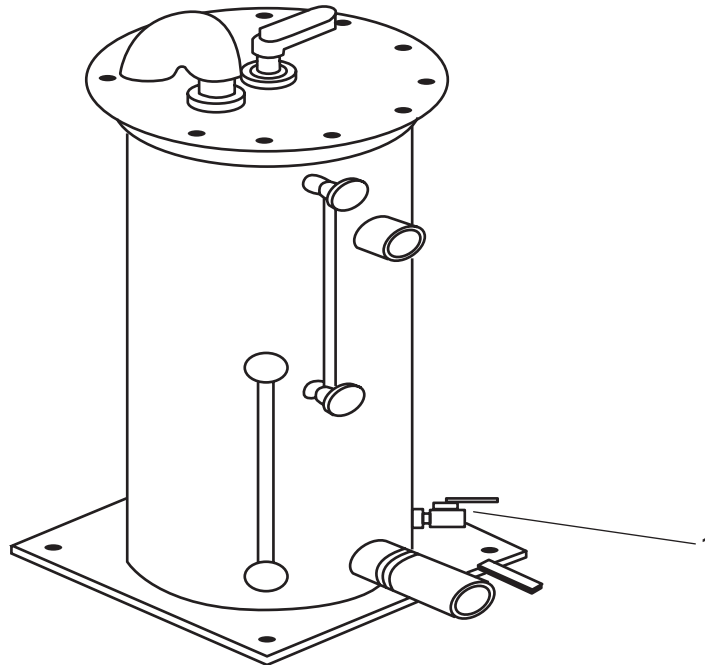
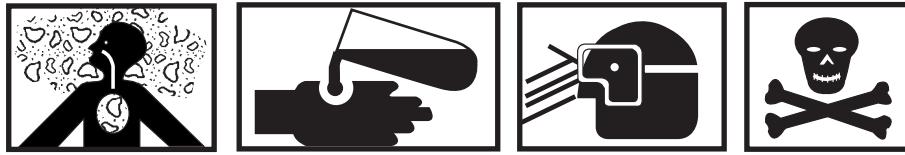

Figure 1. MSD Wet Well

3. Fill a suitable sample bottle with the effluent from the WET WELL SAMPLE valve MSD-11 (figure 1, item 1).
4. Using the sanitizer test kit, dip a chlorine test strip into the sample effluent and move the strip back and forth for 30 seconds.
5. Read the total chlorine level on the sample strip. An acceptable reading will register between 1.0 and 2.0 parts per million (ppm) of total chlorine.
6. If a reading of 0.0 ppm is indicated, take another sample and compare the two readings. If the sample is below 1.0 ppm, adjust the chlorinator to provide more chlorine (WP 0013 00).
7. If the sample is above 2.0 ppm, adjust the chlorinator to provide less chlorine (WP 0013).

CLEAN CHLORINATOR FEED TUBE**REMOVAL****WARNING**

Chlorine tablets can be hazardous. Do not inhale vapors or tablet dust. Protect eyes and skin from contact with tablets. Handle tablets with rubber gloves and a safety shield or goggles. Wash thoroughly with water after contact. Keep away from oil, rags, paper, and other combustible materials. Store in a cool dry area. In case of fire, use water. Failure to comply can lead to serious injury or death.

NOTE

When removing the chlorinator feed tube, place one hand under the end of the chlorinator feed tube that was removed from the chlorinator body to prevent the chlorine tablets from falling out of the chlorinator feed tube.

1. Remove the chlorinator feed tube (figure 2, item 1) from the chlorinator body (figure 2, item 2) by twisting slightly and pulling the chlorinator feed tube straight up.
2. Remove the chlorinator feed tube cover (figure 2, item 3) from the chlorinator feed tube (figure 2, item 1).

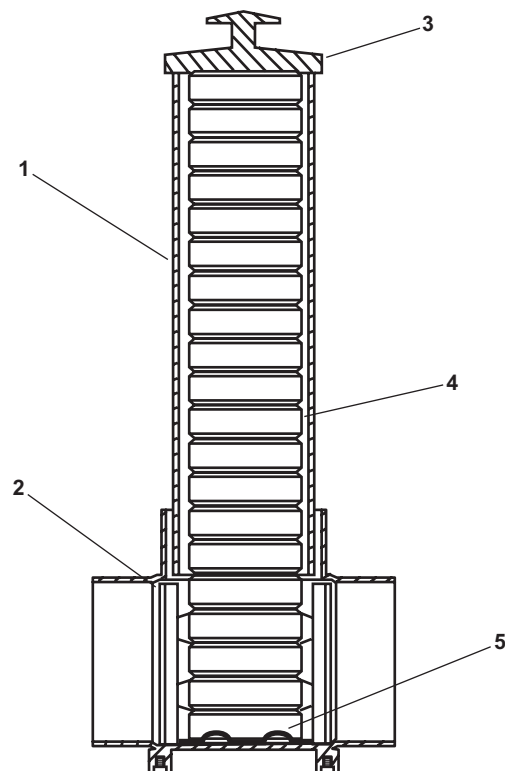

Figure 2. Chlorinator Body

3. Remove any remaining chlorine tablets (figure 2, item 4) from the chlorinator feed tube (figure 2, item 1).
4. Rinse the feed tube (figure 2, item 1) with water and allow it to air dry before proceeding.

INSTALLATION

1. Place the chlorinator feed tube (figure 2, item 1) into the chlorinator body (figure 2, item 2).
2. Lock the chlorinator feed tube (figure 2, item 1) into the positioning ribs (figure 2, item 5) by twisting the chlorinator feed tube slightly.



Chlorine tablets can be hazardous. Do not inhale vapors or tablet dust. Protect eyes and skin from contact with tablets. Handle tablets with rubber gloves and a safety shield or goggles. Wash thoroughly with water after contact. Keep away from oil, rags, paper, and other combustible materials. Store in a cool dry area. In case of fire, use water. Failure to comply can lead to serious injury or death.

3. Insert the chlorine tablets (figure 2, item 4) one at a time into the chlorinator feed tube (figure 2, item 1) ensuring that the chlorine tablets lie flat on top of one another.
4. Install the chlorinator feed tube cover (figure 2, item 3) on the chlorinator feed tube (figure 2, item 1).
5. Perform the residual chlorine test in this work package and adjust the chlorinator (WP 0013 00) as required.

REPLENISH CHLORINATOR TABLETS

1. Remove the chlorinator feed tube cover (figure 2, item 3) from the chlorinator feed tube (figure 2, item 1).



Chlorine tablets can be hazardous. Do not inhale vapors or tablet dust. Protect eyes and skin from contact with tablets. Handle tablets with rubber gloves and a safety shield or goggles. Wash thoroughly with water after contact. Keep away from oil, rags, paper, and other combustible materials. Store in a cool dry area. In case of fire, use water. Failure to comply can lead to serious injury or death.

2. Insert the chlorine tablets (figure 2, item 4) one at a time into the chlorinator feed tube (figure 2, item 1) ensuring that the chlorine tablets lie flat on top of one another.

3. Install the chlorinator feed tube cover (figure 2, item 3) on the chlorinator feed tube (figure 2, item 1).

NOTE

Allow the system to cycle twice.

4. Perform the residual chlorine test in this work package and adjust the chlorinator (WP 0013 00).

AIR SCOUR AND PUMP OUT MEDIA TANK

1. Make an announcement to the vessel that the Marine Sanitation Device (MSD) will be secured until further notice. Crewmembers are not authorized to use the vessel's water closets until further notice.
2. Press the STOP button (figure 3, item 1) on the MSD motor controller (figure 3, item 2).

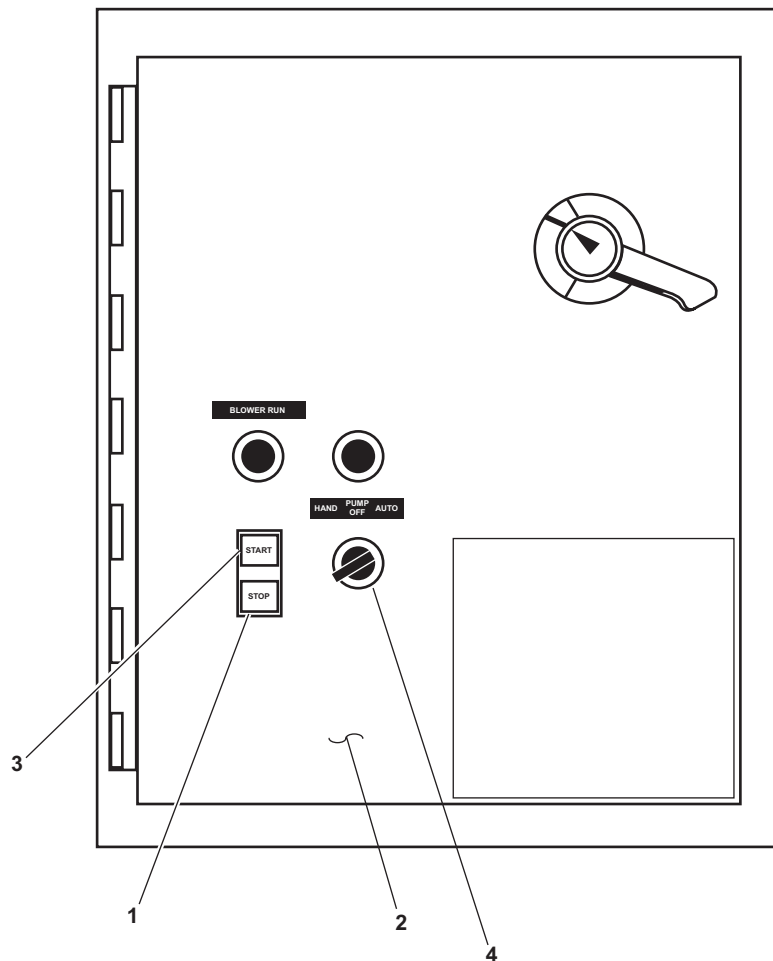

Figure 3. MSD Motor Controller

3. Verify that the blower (figure 4, item 1) has stopped.
4. CLOSE valve SD-1 SEWAGE INLET TO MSD (figure 4, item 2).
5. CLOSE valves MSD-8 MEDIA TANK PUMP-OUT DR (figure 4, item 3) and MSD-9 MEDIA TANK DRAIN (figure 4, item 4).
6. CLOSE valves CA-80 COV-LP AIR (figure 4, item 5) and CA-81 LP AIR SHUTOFF (figure 4, item 6).

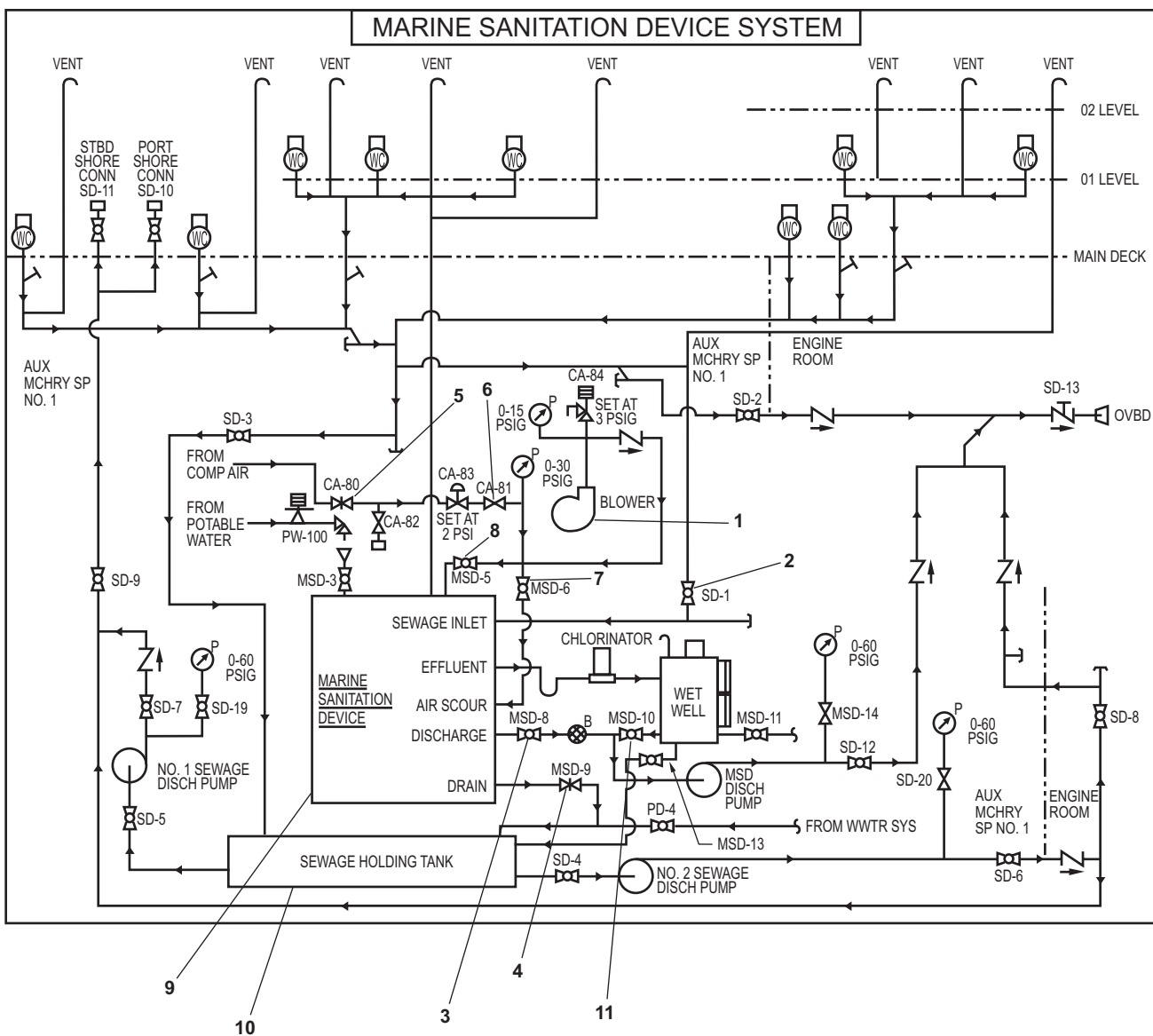

Figure 4. MSD Piping and Valves Schematic

- 7. OPEN valve MSD 6 BLOWER DISCH TO AIR SCOURING SOV (figure 4, item 7).
- 8. CLOSE valve MSD 5 BLOWER DISCHARGE SHUTOFF (figure 4, item 8)

NOTE

Under normal conditions, the blower relief valve lifts during the air scour process. The blower relief valve should return to the seated position after performing the air scour. If the blower relief valve fails to return to the seated position after the air scour, notify the maintenance supervisor.

- 9. Press the START button (figure 3, item 3) on the MSD motor controller (figure 3, item 2).
- 10. Verify that the blower (figure 4, item 1) has started and is supplying 2 PSI (0.138 bar) to the media tank (figure 4, item 9).

11. Allow the air to scour the bottom of the media tank (figure 4, item 9) for at least 30 minutes.
12. Press the STOP button (figure 3, item 1) on the MSD motor controller (figure 3, item 2).
13. Verify that the blower (figure 4, item 1) has stopped.
14. CLOSE valve MSD-6 BLOWER DISCH TO AIR SCOURING SOV (figure 4, item 7).

NOTE

Ensure that the sewage holding tank has adequate capacity to hold the effluent from the media tank before proceeding with this procedure.

15. OPEN valve MSD-9 MEDIA TANK DRAIN (figure 4, item 4) and drain the contents of the media tank (figure 4, item 9) to the sewage holding tank (figure 4, item 10).
16. Allow the media tank (figure 4, item 9) to drain for a minimum of 30 minutes.
17. CLOSE valve MSD-9 MEDIA TANK DRAIN (figure 4, item 4).

NOTE

Do not allow sewage to enter the media tank before it has been filled with water.

18. Fill the MSD with clean water (WP 0005 00).
19. OPEN valve SD-1 SEWAGE INLET TO MSD (figure 4, item 2).
20. Return all valves to their normal operating position (WP 0005 00).
21. Perform the startup procedure for operation under usual conditions (WP 0005 00).
22. Notify the vessel that the MSD is operational and the water closets can be used.

CLEAN MEDIA TANK

DISASSEMBLY

1. Perform the Air Scour and Pump Out Media Tank procedure in this work package through step 19.

NOTE

Ensure that the sewage holding tank has adequate capacity to hold the effluent from the media tank before proceeding with this procedure. If the sewage tank is full, discharge the effluent to a proper shore based facility prior to continuing with this procedure.

2. OPEN valve MSD-9 MEDIA TANK DRAIN (figure 4, item 4) and empty the clean water from the media tank (figure 4, item 9) into the sewage holding tank (figure 4, item 10).
3. Loosen the potable water pipe coupling (figure 5, item 1) and remove the potable water fill piping (figure 5, item 2) from the media tank inspection cover (figure 5, item 4).
4. Verify that valve MSD-5 BLOWER DISCHARGE SHUTOFF (figure 4, item 8) is CLOSED and that the blower (figure 4, item 1) is not operating.
5. CLOSE, lock out, and tag out (FM 55-502) CA-81 LP AIR SHUTOFF (figure 5, item 3).
6. Set to OFF, lock out, and tag out (FM 55-502) the MSD DISCHARGE PUMP AND BLOWER circuit breaker (**LT 803 Only**), or the CONTROLLER FOR MSD DISCHARGE PUMP AND BLOWER circuit breaker (**All Other Vessels**) (figure 6, item 1) in 440V power panel No. 4.

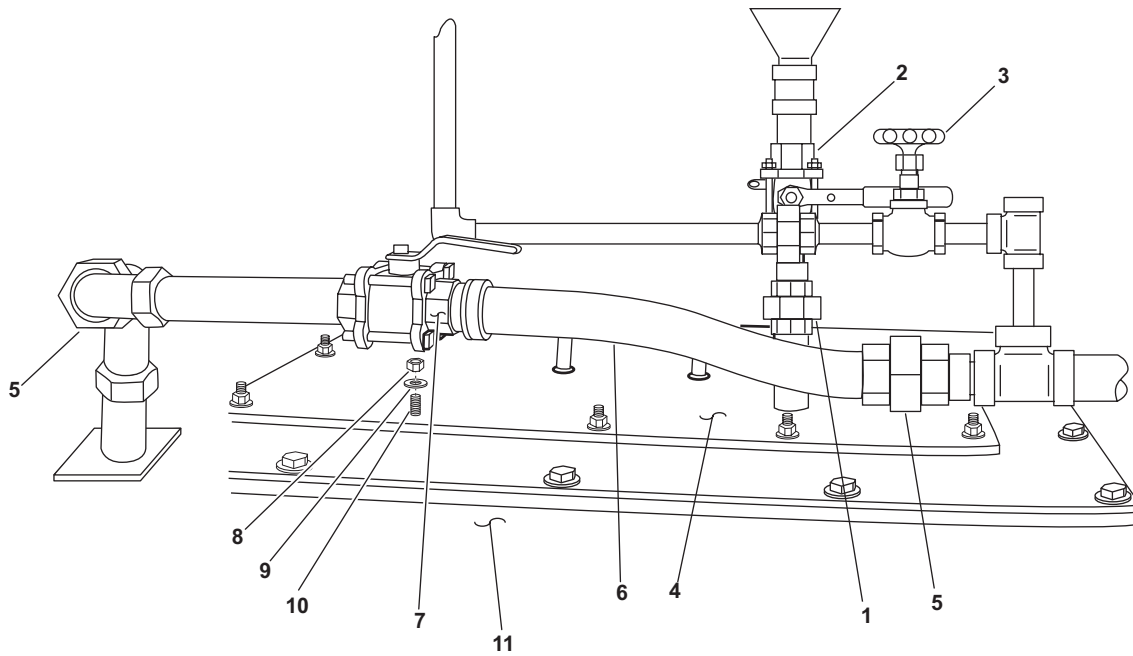

Figure 5. MSD Media Tank Inspection Cover Removal

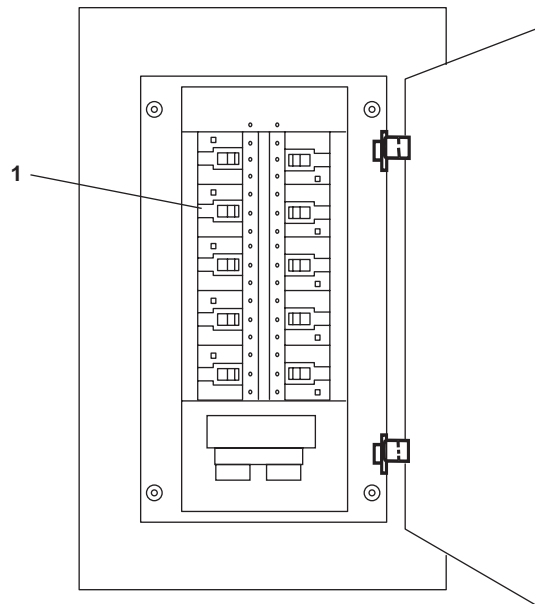

Figure 6. 440V Power Panel No. 4

7. Loosen the compressed air pipe couplings (figure 5, item 5) and remove the compressed air pipe (figure 5, item 6).
8. Remove the 12 nuts (figure 5, item 8) and 12 flat washers (figure 5, item 9) from the 12 studs (figure 5, item 10) in the media tank inspection cover (figure 5, item 4).

WARNING

Sewage is a common mode of transmission for parasitic organisms that may have the capability of causing communicable diseases. After coming in contact with sewage or contaminated equipment, be sure to clean yourself with a disinfectant soap. Avoid sewage contact with skin abrasions, punctures, cuts, and other open wounds. Wipe up and clean any spills and/or contaminated equipment using a disinfectant soap. Failure to comply can result in serious illness.

Heavy loads can crush. Do not allow any body parts to come under the load or between the load and a stationary object. Death or serious injury can result.

- Remove the media tank inspection cover (figure 5, item 4) from the media tank (figure 5, item 11).

CLEANING AND INSPECTION

- Inspect the airlift (figure 7, item 1) and airlift drop hose assembly (figure 7, item 2) for damage and corrosion.
- Inspect the spillover pipe assembly (figure 7, item 3) to make sure it is in place and not damaged.
- Use a hose and nozzle connected to a clean water supply not exceeding 75 PSI (5.1 bar) to clean the accumulated microorganisms from the tank walls (figure 7, item 4), airlift drop (figure 7, item 2), spillover pipe (figure 7, item 3), and media (figure 7, item 5).
- Clean all of the silicone from the media tank inspection cover (figure 5, item 4) and the media tank (figure 5, item 11).

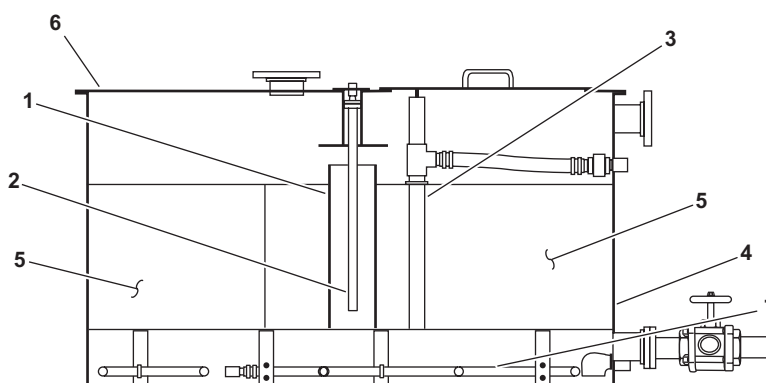

Figure 7. MSD Media Tank Internal Components

ASSEMBLY

- Close valve MSD-9 MEDIA TANK DRAIN (figure 4, item 4).
- Connect the compressed air pipe (figure 5, item 6) and tighten the compressed air pipe couplings (figure 5, item 5).

3. Remove the lockouts and tagouts (FM 55-502).
4. Fill and startup the MSD under usual conditions (WP 0005 00).
5. Ensure that the water level in the media tank (figure 7, item 6) is at the top of the airlift (figure 7, item 1) approximately 3 inches (76 mm) above the media (figure 7, item 5).
6. OPEN valve MSD-6 BLOWER DISCH TO AIR SCOURING SOV (figure 4, item 7) and CLOSE valve MSD-5 BLOWER DISCHARGE SHUTOFF (figure 4, item 8).
7. Verify that air bubbles appear in the water within the tank indicating that the air scour (figure 7, item 7) is operating properly. If air bubbles are not present in the water, perform the Disassembly, Cleaning and Inspection portion of this procedure until the accumulated sludge over the air scour has been removed and air bubbles are present in the water. Once it has been determined that the air scour is operating properly, continue with the procedure.
8. CLOSE valve MSD-6 BLOWER DISCH TO AIR SCOURING SOV (figure 4, item 7) and OPEN valve MSD-5 BLOWER DISCHARGE SHUTOFF (figure 4, item 8).
9. Apply a continuous 1/4 inch (6 mm) bead of silicone compound (sealant) on the opening of the media tank (figure 7, item 6). Circle each bolt hole in the media tank inspection cover (figure 5, item 4) with a 1/8 inch (3 mm) bead of silicone compound.



Heavy loads can crush. Do not allow any body parts to come under the load or between the load and a stationary object. Death or serious injury can result.

10. Install the media tank inspection cover (figure 5, item 4) on the media tank (figure 5, item 11) and secure it with the 12 flat washers (figure 5, item 9) and 12 nuts (figure 5, item 8).
11. Connect the potable water fill piping (figure 5, item 2) to the media tank inspection cover (figure 5, item 4) and tighten the potable water pipe coupling (figure 5, item 1).

CLEAN WET WELL INLET STRAINER

DISASSEMBLY

1. Set to OFF the HAND, PUMP OFF, AUTO switch (figure 3, item 4) on the MSD motor controller (figure 3, item 2). Lock out and tag out (FM 55-502).
2. CLOSE, lock out and tag out (FM 55-502) valves MSD-8 MEDIA TANK PUMP-OUT DR (figure 4, item 3) and MSD-10 WET WELL DISCHARGE (figure 4, item 11).
3. Loosen the yoke screw (figure 8, item 1) on the wet well inlet strainer (figure 8, item 2).



Sewage is a common mode of transmission for parasitic organisms that may have the capability of causing communicable diseases. After coming in contact with sewage or contaminated equipment, be sure to clean yourself with a disinfectant soap. Avoid sewage contact with skin abrasions, punctures, cuts, and other open wounds. Wipe up and clean any spills and/or contaminated equipment using a disinfectant soap. Failure to comply can result in serious illness.

4. Swing the yoke (figure 8, item 3) clear of the cover (figure 8, item 4) of the wet well inlet strainer (figure 8, item 2).
5. Remove the cover (figure 8, item 4) from the wet well inlet strainer (figure 8, item 2).

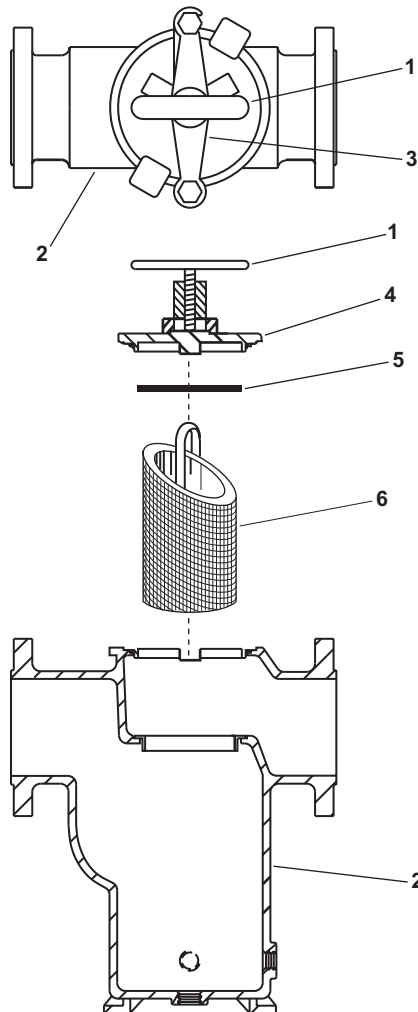

Figure 8. Wet Well Inlet Strainer

6. Remove and discard the gasket (figure 8, item 5).
7. Remove the basket (figure 8, item 6) from the wet well inlet strainer (figure 8, item 2).
8. Clean the basket (figure 8, item 6) with fresh water.

ASSEMBLY

1. Install the basket (figure 8, item 6) in the wet well inlet strainer (figure 8, item 2).
2. Install the cover (figure 8, item 4) and new gasket (figure 8, item 5).
3. Swing the yoke (figure 8, item 3) into place and tighten the yoke screw (figure 8, item 1).
4. Remove the lockouts and tagouts (FM-55-502).
5. OPEN valves MSD-8 MEDIA TANK PUMP-OUT DR (figure 4, item 3) and MSD-10 WET WELL DISCHARGE (figure 4, item 11).
6. Return the MSD to operation under usual conditions (WP 0005 00) and check for leaks.
7. Return the equipment to the desired readiness condition.

END OF WORK PACKAGE

**OPERATOR MAINTENANCE
MARINE SANITATION DEVICE FOR
INLAND AND COASTAL LARGE TUG (LT)
CONTROLLER, REPAIR**

INITIAL SETUP:**Tools and Special Tools:**

Tool Kit, General Mechanic's (Item 1, Table 2,
WP 0035 00)

Materials/Parts:

Tag, Danger (Item 7, Table 1, WP 0039 00)
Lamp, Incandescent (Item 3, Figure 2,
WP 0037 00)

Personnel Required:

Two Watercraft Engineers, 88L

References:

FM 55-502
WP 0005 00
WP 0035 00
WP 0037 00
WP 0039 00

Equipment Conditions:

Set to OFF the MSD DISCHARGE PUMP AND BLOWER circuit breaker (**LT 803 Only**), or the CONTROLLER FOR MSD DISCHARGE PUMP AND BLOWER circuit breaker (**All Other Vessels**) in 440V power panel No. 4. Lock out and tag out (FM 55-502).

LAMP REPLACEMENT**REMOVAL**

Replace or repair components only after the affected circuit has been secured, locked out, and tagged out. Performing replacement with the circuit energized may result in injury.

1. Unscrew and remove the light indicator lens cap (figure 1, item 1) from the indicator light housing (figure 1, item 2).
2. Unscrew and remove the lamp (figure 1, item 3) from the indicator light housing (figure 1, item 2).

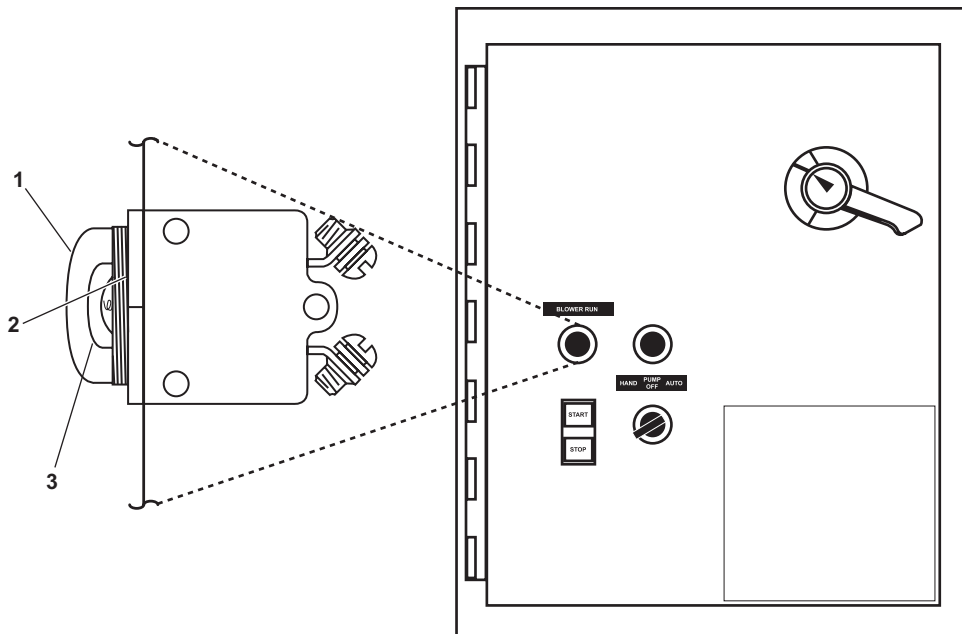

Figure 1. MSD Motor Controller

INSTALLATION

1. Thread the lamp (figure 1, item 3) into the indicator light housing (figure 1, item 2) until it is finger tight.
2. Thread the lens cap (figure 1, item 1) into the indicator light housing (figure 1, item 2) until it is finger tight.
3. Remove lockouts and tagouts (FM 55-502).
4. Operate the MSD (WP 0005 00).
5. Return the equipment to the desired readiness condition.

END OF WORK PACKAGE

**OPERATOR MAINTENANCE
MARINE SANITATION DEVICE FOR
INLAND AND COASTAL LARGE TUG (LT)
BLOWER ASSEMBLY, ADJUST**

INITIAL SETUP:**Tools and Special Tools:**

Tool Kit, General Mechanic's (Item 1, Table 2,
WP 0035 00)
Suitable Straight Edge

Materials/Parts:

Gloves, Chemical and Oil Protective (Item 1,
Table 3, WP 0038 00)
Goggles, Industrial (Item 2, Table 3,
WP 0038 00)
Tag, Danger (Item 7, Table 1, WP 0039 00)
Tape, Antiseizing (Item 8, Table 1, WP 039 00)
Belt, Drive, Blower (Item 2, Figure 3,
WP 0037 00)

Personnel Required:

Two Watercraft Engineers, 88L

References:

FM 55-502
TB 43-0218
WP 0005 00
WP 0035 00
WP 0037 00
WP 0038 00
WP 0039 00

Equipment Conditions:

Set to OFF the MSD DISCHARGE PUMP AND BLOWER circuit breaker (**LT 803 Only**), or the CONTROLLER FOR MSD DISCHARGE PUMP AND BLOWER circuit breaker (**All Other Vessels**) in 440V power panel No. 4. Lock out and tag out (FM 55-502).

WARNING

Never reuse locking hardware. Reuse of locking hardware such as lockwashers, locking nuts, cotter pins, and lock wire can result in undetected loosening of fastening hardware causing catastrophic component failure resulting in death, injury, or damage to equipment. In accordance with TB 43-0218, ensure that all locking hardware is discarded upon removal and replaced with new.

BELT REPLACEMENT**REMOVAL**

1. Remove the four nuts (figure 1, item 1) and four lockwashers (figure 1, item 2) from the studs (figure 1, item 3) that secure the belt guard (figure 1, item 4). Discard the lockwashers.
2. Remove the belt guard (figure 1, item 4) from its base (figure 1, item 5).
3. Loosen, but do not remove, the four bolts (figure 1, item 6) that secure the motor (figure 1, item 7) to its base (figure 1, item 8).
4. Slide the motor (figure 1, item 7) towards the blower (figure 1, item 9) until the belt (figure 1, item 10) is loose enough to be removed from the motor sheave (figure 1, item 11) and the blower sheave (figure 1, item 12).
5. Remove the belt (figure 1, item 10) from the motor sheave (figure 1, item 11) and the blower sheave (figure 1, item 12). Discard the belt.

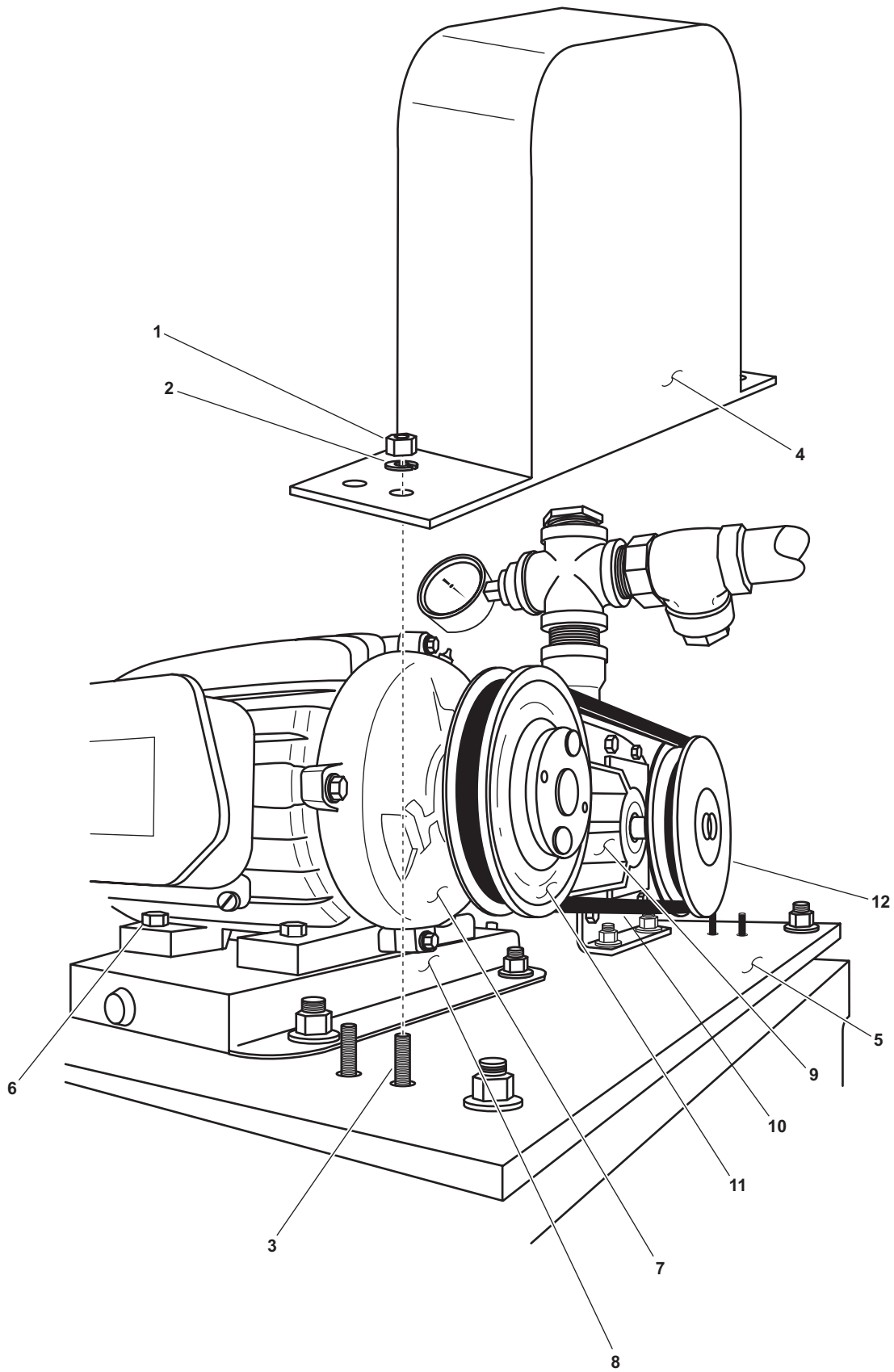

Figure 1. Blower and Motor Belt Guard Removal

INSTALLATION

1. Install a new belt (figure 1, item 10) on the blower sheave (figure 1, item 12) and the motor sheave (figure 1, item 11).
2. Slide the motor (figure 1, item 7) away from the blower (figure 1, item 9) until the proper belt tension is achieved. Proper tension is achieved when the belt may be deflected 1/2 inch (13 mm) at its midpoint (figure 2) when applying approximately 4 to 5 pounds (1.8 to 2.3 kg) of force to the belt. A new belt should be tensioned tighter (approximately 3/8 inch (10 mm) deflection).

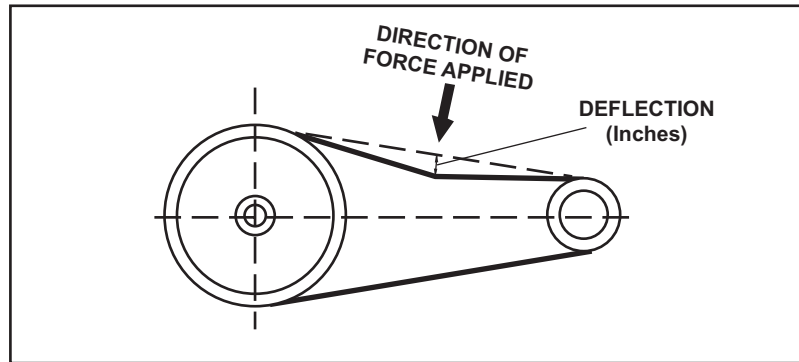

Figure 2. Belt Adjustment

3. Tighten the four bolts (figure 1, item 6).
4. Perform the Sheave Alignment procedures in this work package.
5. Check the belt tension several times during the first 50 hours of operation. Adjust if necessary. Use the procedure detailed in step 2 above for checking tension and adjusting the belt.
6. Position the belt guard (figure 1, item 4) over the studs (figure 1, item 3) on its base (figure 1, item 5) and secure it with the four nuts (figure 1, item 1) and four new lockwashers (figure 1, item 2).
7. Perform the Follow-On Service procedure at the end of this work package.

BELT ADJUSTMENT

DISASSEMBLY

1. Remove the four nuts (figure 1, item 1) and four lockwashers (figure 1, item 2) from the studs (figure 1, item 3) that secure the belt guard (figure 1, item 4). Discard the lockwashers.
2. Remove the belt guard (figure 1, item 4) from its base (figure 1, item 5).
3. Loosen, but do not remove, the four bolts (figure 1, item 6) that secure the motor (figure 1, item 7) to its base (figure 1, item 8).
4. Slide the motor (figure 1, item 7) towards the blower (figure 1, item 9) until the belt (figure 1, item 10) is loose enough to be removed from the motor sheave (figure 1, item 11) and the blower sheave (figure 1, item 12).
5. Inspect the belt (figure 1, item 10) for damage, including signs of wear, tears, cuts, and nicks. Replace the belt if any of the conditions listed are present.

ASSEMBLY

1. Slide the motor (figure 1, item 7) away from the blower (figure 1, item 9) until the proper belt tension is achieved. Proper tension is achieved when the belt may be deflected 1/2 inch (13 mm) at its midpoint (figure 2) when applying approximately 4 to 5 pounds (1.8 to 2.3 kg) of force to the belt. A new belt should be tensioned tighter (approximately 3/8 inch (10 mm) deflection).
2. Tighten the four bolts (figure 1, item 6).
3. Perform the Sheave Alignment procedures in this work package.
4. Check the belt tension several times during the first 50 hours of operation. Adjust if necessary. Use the Belt Replacement Installation procedure in this work package for checking tension and adjusting the belt.
5. Perform the Follow-On Service procedure at the end of this work package.

PARALLEL SHEAVE ALIGNMENT**DISASSEMBLY**

1. Remove the four nuts (figure 1, item 1) and four lockwashers (figure 1, item 2) from the studs (figure 1, item 3) that secure the belt guard (figure 1, item 4). Discard the lockwashers.
2. Remove the belt guard (figure 1, item 4) from its base (figure 1, item 5).
3. Check for parallel sheave misalignment (figure 3) by placing a suitable straight edge (figure 3, item 1) against the machined surface of the sheaves (figure 3, item 2). Ensure that the straight edge is perpendicular to both shafts while maintaining contact.
4. If the sheaves are not aligned, remove the two bolts (figure 4, item 1) on the blower sheave (figure 4, item 2). If the sheaves are aligned, proceed to step 2 of the assembly procedure.
5. Loosen, but do not remove, the four bolts (figure 1, item 6) that secure the motor (figure 1, item 7) to its base (figure 1, item 8).
6. Slide the motor (figure 1, item 7) towards the blower (figure 1, item 9) until the belt (figure 1, item 10) is loose enough to be removed from the motor sheave (figure 1, item 11) and the blower sheave (figure 1, item 12).
7. Remove the belt (figure 1, item 10) from the motor sheave (figure 1, item 11) and the blower sheave (figure 1, item 12).
8. Install one of the bolts (figure 4, item 1) in the forcing hole (figure 4, item 3) and tighten until the blower sheave is freed from the blower shaft (figure 4, item 4).
9. Remove the bolt (figure 4, item 1) from the forcing hole (figure 4, item 3).

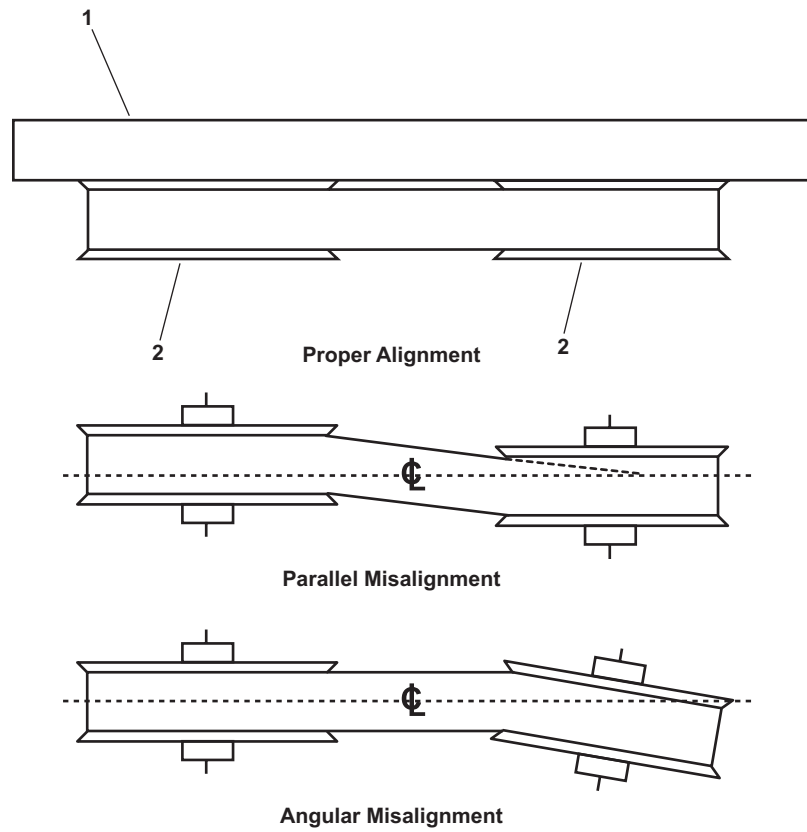

Figure 3. Sheave Alignment

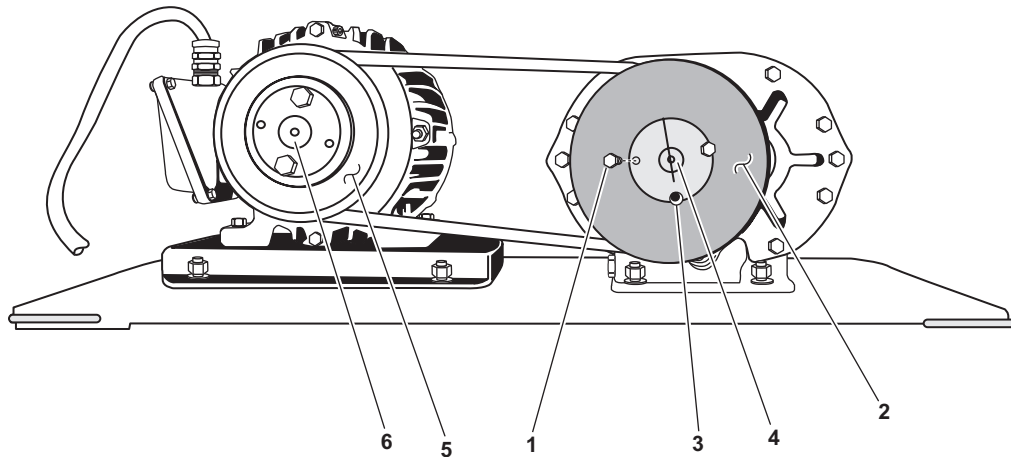

Figure 4. Blower Sheave Removal

ASSEMBLY

1. Position the blower sheave (figure 4, item 2) on the blower shaft (figure 4, item 4) so that the suitable straight edge (figure 3, item 1) rests against the machined surfaces of the blower sheave (figure 4, item 2) and the motor sheave (figure 4, item 5). Ensure that the suitable straight edge is perpendicular to the blower shaft (figure 4, item 4) and the motor shaft (figure 4, item 6) while making contact with the blower and motor sheaves.

2. Once parallel alignment is achieved, install the two bolts (figure 4, item 1) in the blower sheave (figure 4, item 2).
3. Install the belt (figure 1, item 10) on the motor sheave (figure 1, item 11) and the blower sheave (figure 1, item 12).
4. Slide the motor (figure 1, item 7) away from the blower (figure 1, item 9) until the proper belt tension is achieved. Proper tension is achieved when the belt may be deflected 1/2 inch (13 mm) at its midpoint (figure 2) when applying approximately 4 to 5 pounds (1.8 to 2.3 kg) of force to the belt. A new belt should be tensioned tighter (approximately 3/8 inch (10 mm) deflection).
5. Tighten the four bolts (figure 1, item 6).
6. Check the belt tension several times during the first 50 hours of operation. Adjust if necessary. Use the Adjust Belt procedure in this work package for checking tension and adjusting the belt.
7. Position the belt guard (figure 1, item 4) over the studs (figure 1, item 3) on its base (figure 1, item 5) and secure it with the four nuts (figure 1, item 1) and four new lockwashers (figure 1, item 2).
8. Perform the Follow-On Service procedure at the end of this work package.

ANGULAR SHEAVE ALIGNMENT

DISASSEMBLY

1. Remove the four nuts (figure 1, item 1) and four lockwashers (figure 1, item 2) from the studs (figure 1, item 3) that secure the belt guard (figure 1, item 4). Discard the lockwashers.
2. Remove the belt guard (figure 1, item 4) from its base (figure 1, item 5).
3. Check for angular sheave misalignment (figure 3) by placing a suitable straight edge (figure 3, item 1) against the machined surface of the sheaves (figure 3, item 2). Ensure that the straight edge is perpendicular to both shafts while maintaining contact.
4. If the sheaves are not aligned, proceed to step 5. If the sheaves are aligned, proceed to step 5 of the assembly procedure.
5. Loosen, but do not remove, the four bolts (figure 1, item 6) that secure the motor (figure 1, item 7) to its base (figure 1, item 8).
6. Slide the motor (figure 1, item 7) towards the blower (figure 1, item 9) until the belt (figure 1, item 10) is loose enough to be removed from the motor sheave (figure 1, item 11) and the blower sheave (figure 1, item 12).

ASSEMBLY

1. Place the suitable straight edge (figure 3, item 1) against the machined surface of the sheaves (figure 3, item 2). Ensure that the straight edge is perpendicular to both shafts while maintaining contact.
2. Keeping the suitable straight edge on the sheaves (figure 3, item 2), slide the motor (figure 1, item 7) away from the blower (figure 1, item 9) until the proper belt tension is achieved. Proper tension is achieved when the belt may be deflected 1/2 inch (13 mm) at its midpoint (figure 2) when applying approximately 4 to 5 pounds (1.8 to 2.3 kg) of force to the belt. A new belt should be tensioned tighter (approximately 3/8 inch (10 mm) deflection).
3. Verify that the angular misalignment has been corrected. If angular misalignment is not corrected, repeat steps 1 and 2 until it is.

4. Tighten the four bolts (figure 1, item 6).
5. Check the belt tension several times during the first 50 hours of operation. Adjust if necessary. Use the Adjust Belt procedure of this work package for checking tension and adjusting the belt.
6. Position the belt guard (figure 1, item 4) over the studs (figure 1, item 3) on its base (figure 1, item 5) and secure it with the four nuts (figure 1, item 1) and four new lockwashers (figure 1, item 2).
7. Perform the Follow-On Service procedure at the end of this work package.

FOLLOW-ON SERVICE

1. Remove the lockouts and tagouts (FM 55-502).
2. Operate the MSD under usual conditions (WP 0005 00).
3. Check the blower for proper operation.
4. Return the equipment to the desired readiness condition.

END OF WORK PACKAGE

**OPERATOR MAINTENANCE
MARINE SANITATION DEVICE FOR
INLAND AND COASTAL LARGE TUG (LT)
BLOWER ASSEMBLY, SERVICE**

INITIAL SETUP:**Tools and Special Tools:**

Tool Kit, General Mechanic's (Item 1, Table 2, WP 0035 00)
Lubricating Gun, Hand (Item 5, Table 2, WP 0035 00)
Suitable drain pan

Materials/Parts:

Dry Cleaning Solvent (Item 1, Table 1, WP 0039 00)
Gloves, Chemical and Oil Protective (Item 1, Table 3, WP 0038 00)
Grease, General Purpose (Item 2, Table 1, WP 0039 00)
Rag, Wiping (Item 4, Table 1, WP 0039 00)
Tag, Danger (Item 7, Table 1, WP 0039 00)
Tape, Antiseizing (Item 8, Table 1, WP 0039 00)

Personnel Required:

Two Watercraft Engineers, 88L

References:

FM 55-502
TB 43-0218
WP 0005 00
WP 0035 00
WP 0038 00
WP 0039 00

Equipment Conditions:

Set to OFF the MSD DISCHARGE PUMP AND BLOWER circuit breaker (**LT 803 Only**), or the CONTROLLER FOR MSD DISCHARGE PUMP AND BLOWER circuit breaker (**All Other Vessels**) in 440V power panel No. 4. Lock out and tag out (FM 55-502).

WARNING

Never reuse locking hardware. Reuse of locking hardware such as lockwashers, locking nuts, cotter pins, and lockwire can result in undetected loosening of fastening hardware causing catastrophic component failure resulting in death, injury, or damage to equipment. In accordance with TB 43-0218, ensure that all locking hardware is discarded upon removal and replaced with new.

LUBRICATE BLOWER BEARINGS**DISASSEMBLY**

1. Remove the four nuts (figure 1, item 1) and four lockwashers (figure 1, item 2) from the studs (figure 1, item 3) that secure the belt guard (figure 1, item 4). Discard the lockwashers.
2. Remove the belt guard (figure 1, item 4) from its base (figure 1, item 5).

NOTE

The drive shaft end bearings should be greased weekly.

3. Using a lubricating gun, pump new general purpose grease into each drive shaft end bearing's grease fitting (figure 2, item 1) until clean grease comes out of the relief fitting (figure 2, item 2).

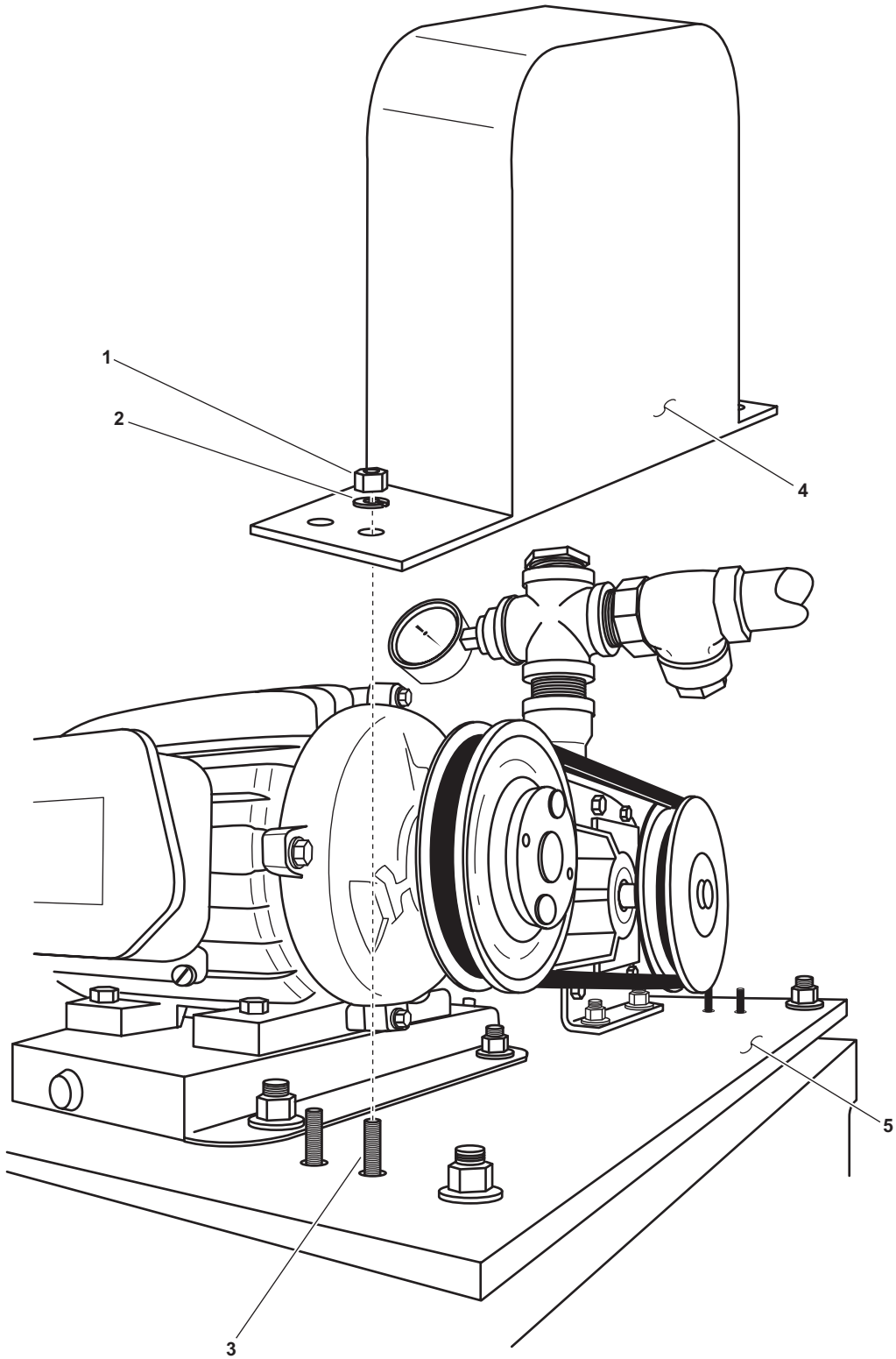

Figure 1. Belt Guard Removal

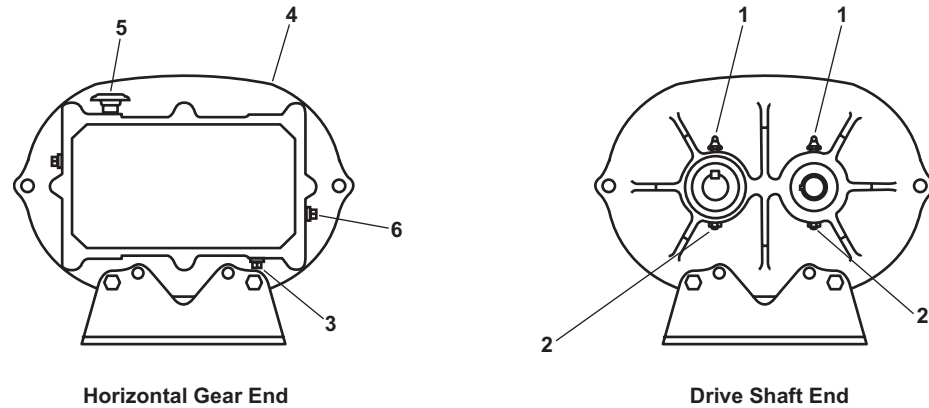

Figure 2. Blower Service Locations

ASSEMBLY

1. Use clean wiping rags to remove all remaining grease from the work area.
2. Position the belt guard (figure 1, item 4) over the studs (figure 1, item 3) on its base (figure 1, item 5) and secure it with the four nuts (figure 1, item 1) and four new lockwashers (figure 1, item 2).
3. Perform the Follow-On Service procedure at the end of this work package.

CHANGE BLOWER OIL

DISASSEMBLY

1. Remove the four nuts (figure 1, item 1) and four lockwashers (figure 1, item 2) from the studs (figure 1, item 3) that secure the belt guard (figure 1, item 4). Discard the lockwashers.
2. Remove the belt guard (figure 1, item 4) from its base (figure 1, item 5).
3. Position a suitable drain pan under the oil drain plug (figure 2, item 3) of the blower (figure 2, item 4).

WARNING



Do not allow hydraulic fluid, engine oil, or cleaning solvents to come in contact with unprotected skin or eyes. Prolonged skin contact can cause illness or injury. Eye contact can cause serious injury. Always wear chemical protective gloves and goggles when handling hydraulic fluid, engine oil, and cleaning solvents. Failure to follow these precautions can result in illness or serious injury.

4. Remove the oil drain plug (figure 2, item 3) and allow the oil to drain into the suitable drain pan.
5. Remove the breather (figure 2, item 5) and the oil overflow plug (figure 2, item 6).

ASSEMBLY

1. Wrap the male pipe threads of the oil drain plug (figure 2, item 3) with antiseizing tape and install the oil drain plug in the blower (figure 2, item 4).



Do not allow hydraulic fluid, engine oil, or cleaning solvents to come in contact with unprotected skin or eyes. Prolonged skin contact can cause illness or injury. Eye contact can cause serious injury. Always wear chemical protective gloves and goggles when handling hydraulic fluid, engine oil, and cleaning solvents. Failure to follow these precautions can result in illness or serious injury.

2. Fill the blower (figure 2, item 4) with new oil (table 1) through the breather (figure 2, item 5) until the oil runs out of the overflow (figure 2, item 6).

Table 1. Recommended Oil Grades

Temperature	SAE
Above 90°F (32°C)	50
32°F to 90°F (0°C to 32°C)	40
0°F to 32°F (-18°C to 0°C)	30

3. Wrap the male threads of the breather (figure 2, item 5) and the overflow plug (figure 2, item 6) with antiseizing tape and install them into their respective holes.



Cleaning solvent is flammable and its vapor is potentially explosive. Do not use cleaning solvent in the vicinity of spark, open flame, or excessive heat. Do not use cleaning solvent in unventilated spaces. Failure to follow these precautions can result in death or serious injury.

4. Use clean wiping rags and dry cleaning solvent to clean the work area.
5. Position the belt guard (figure 1, item 4) over the studs (figure 1, item 3) on its base (figure 1, item 5) and secure it with the four nuts (figure 1, item 1) and four new lockwashers (figure 1, item 2).
6. Perform the Follow-On Service procedure at the end of this work package.

FOLLOW-ON SERVICE

1. Remove the lockouts and tagouts (FM 55-502).
2. Operate the MSD under usual conditions (WP 0005 00).
3. Check the blower for proper operation.
4. Return the equipment to the desired readiness condition.

END OF WORK PACKAGE

**OPERATOR MAINTENANCE
MARINE SANITATION DEVICE FOR
INLAND AND COASTAL LARGE TUG (LT)
BLOWER ASSEMBLY, REPAIR**

INITIAL SETUP:**Tools and Special Tools:**

Tool Kit, General Mechanic's (Item 1, Table 2,
WP 0035 00)

Materials/Parts:

Tape, Antiseizing (Item 8, Table 1, WP 0039 00)
Tag, Danger (Item 7, Table 1, WP 0039 00)

Personnel Required:

Two Watercraft Engineers, 88L

References:

FM 55-502
WP 0005 00
WP 0035 00
WP 0039 00

Equipment Conditions:

Set to OFF the MSD DISCHARGE PUMP AND BLOWER circuit breaker (**LT 803 Only**), or the CONTROLLER FOR MSD DISCHARGE PUMP AND BLOWER circuit breaker (**All Other Vessels**) in 440V power panel No. 4. Lock out and tag out (FM 55-502).

SILENCER REPLACEMENT**REMOVAL**

 **CAUTION**

Never attempt to disconnect union connections with only one wrench. Damage to the vessel's standing piping could occur. Always use two wrenches.

1. Disconnect the union (figure 1, item 1) on the silencer (figure 1, item 2).
2. Remove the silencer (figure 1, item 2).
3. Remove the pipe fittings (figure 1, item 3) from the silencer (figure 1, item 2) and the male pipe threads (figure 1, item 4) of the blower (figure 1, item 5).

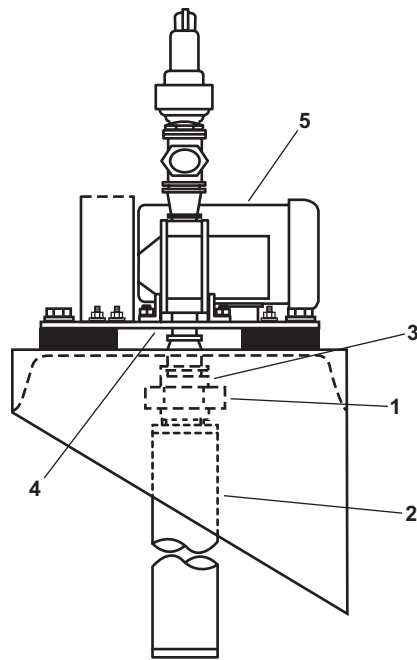

Figure 1. Silencer Replacement

INSTALLATION

1. Wrap the male pipe threads (figure 1, item 4) with antiseizing tape.
2. Install the pipe fittings (figure 1, item 3) in the silencer (figure 1, item 2).

CAUTION

Never attempt to connect union connections with only one wrench. Damage to the vessel's standing piping could occur. Always use two wrenches.

3. Connect the union (figure 1, item 1) on the silencer (figure 1, item 2).
4. Remove the lockouts and tagouts (FM 55-502).
5. Operate the MSD under usual conditions (WP 0005 00).
6. Check the blower for proper operation.
7. Return the equipment to the desired readiness condition.

END OF WORK PACKAGE

**OPERATOR MAINTENANCE
MARINE SANITATION DEVICE FOR
INLAND AND COASTAL LARGE TUG (LT)
WET WELL, REPAIR**

INITIAL SETUP:**Tools and Special Tools:**

Tool Kit, General Mechanic's (Item 1, Table 2, WP 0035 00)

Materials/Parts:

Gloves, Chemical and Oil Protective (Item 1, Table 3, WP 0038 00)

Goggles, Industrial (Item 2, Table 3, WP 0038 00)

Tag, Danger (Item 7, Table 1, WP 0039 00)

Tape, Antiseizing (Item 8, Table 1, WP 0039 00)

Indicator, Sight, Liquid (Item 2, Figure 6, WP 0037 00)

Personnel Required:

Two Watercraft Engineers, 88L

References:

FM 55-502

TM 55-1925-273-10

WP 0005 00

WP 0035 00

WP 0037 00

WP 0038 00

WP 0039 00

Equipment Conditions:

Set to OFF the MSD DISCHARGE PUMP AND BLOWER circuit breaker (**LT 803 Only**), or the CONTROLLER FOR MSD DISCHARGE PUMP AND BLOWER circuit breaker (**All Other Vessels**) in 440V power panel No. 4. Lock out and tag out (FM 55-502).

All ventilation fans operating normally (TM 55-1925-273-10)

SIGHT GLASS REPLACEMENT**REMOVAL**

1. CLOSE the SEWAGE INLET TO MSD valve, SD-1 (figure 1, item 1).
2. OPEN the SEWAGE DRAIN TO HOLDING TANK valve SD-3 (figure 1, item 2).
3. CLOSE the WET WELL DISCHARGE valve, MSD-10 (figure 1, item 3).

NOTE

Ensure that the sewage holding tank has adequate capacity to hold the effluent from the wet well before proceeding with this procedure. If the sewage holding tank is full, discharge the effluent to a proper shore based facility prior to continuing with this procedure.

4. OPEN the WET WELL DRAIN TO HOLDING TANK valve, MSD-13 (figure 1, item 4) and drain the wet well into the SEWAGE HOLDING TANK (figure 1, item 5).
5. CLOSE the sight glass (liquid sight indicator) inlet valve (figure 2, item 1) and the sight glass outlet valve (figure 2, item 2) on the affected sight glass (figure 2, item 3).
6. Remove the rods (figure 2, item 4) that hold the sight glass assembly (figure 2, item 5) together.

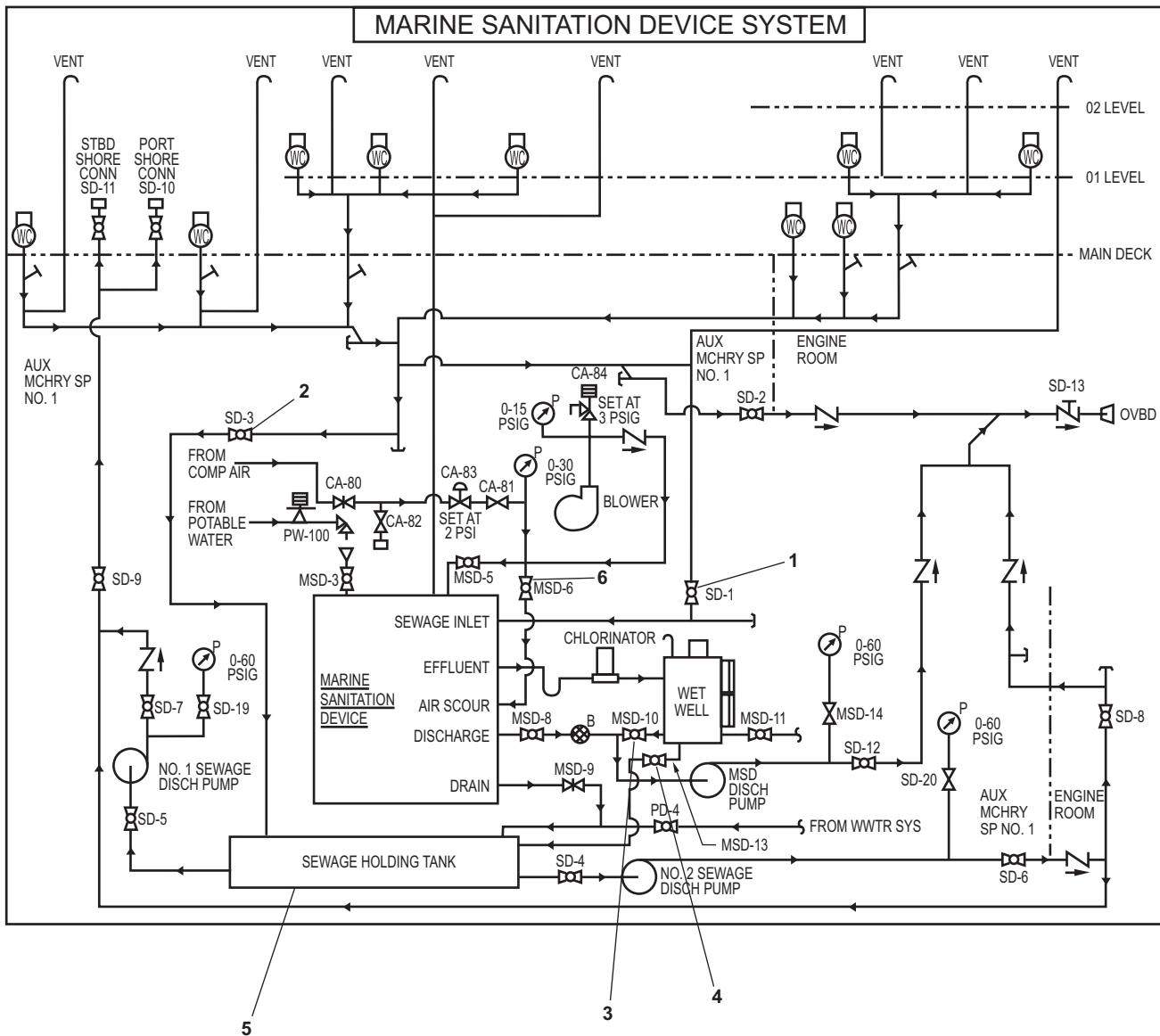

Figure 1. MSD Piping and Valve Schematic

7. Unscrew the collars (figure 2, item 6) from the inlet valve (figure 2, item 1) and the outlet valve (figure 2, item 2).
8. Slide the sight glass (figure 2, item 7) up into the outlet valve (figure 2, item 2) and then down and out to remove it.
9. Remove the O-rings (figure 2, item 8) from the inlet valve (figure 2, item 1) and the outlet valve (figure 2, item 2). Discard the O-rings.
10. Unscrew the inlet valve (figure 2, item 1) and the outlet valve (figure 2, item 2) from the wet well (figure 2, item 9).

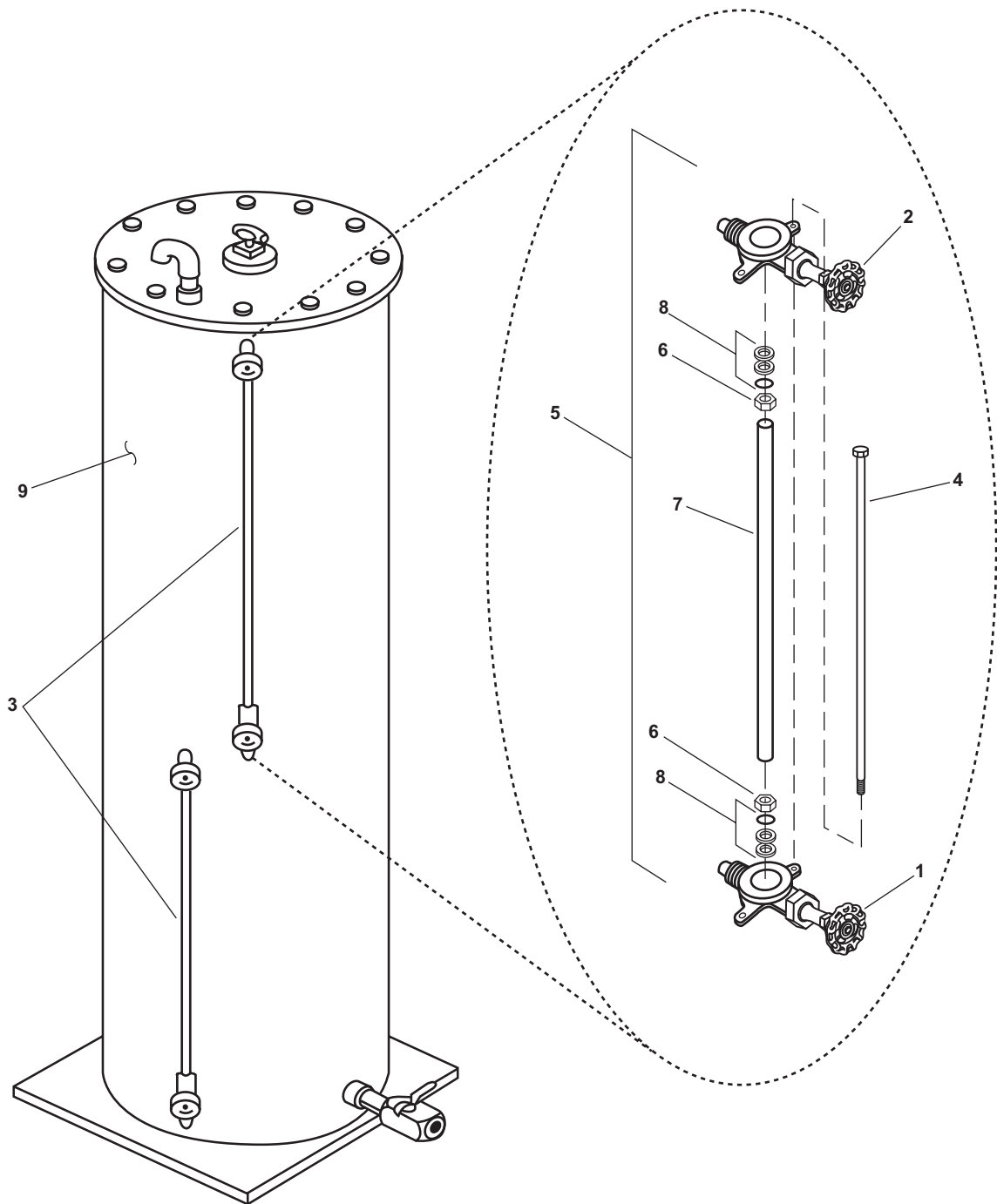

Figure 2. Wet Well Sight Glass Replacement

INSTALLATION

1. Wrap the male pipe threads of the inlet valve (figure 2, item 1) and outlet valve (figure 2, item 2) with anti-seizing tape and thread them into the wet well (figure 2, item 9).
2. Install new O-rings (figure 2, item 8) into the outlet valve (figure 2, item 2) and the inlet valve (figure 2, item 1).
3. Slide the collars (figure 2, item 6) onto the new sight glass (figure 2, item 7).

-
4. Slide the sight glass (figure 2, item 7) up into the outlet valve (figure 2, item 2) and then down into the inlet valve (figure 2, item 1). Secure the sight glass by tightening the collars (figure 2, item 6).
 5. Install the rods (figure 2, item 4) in the sight glass assembly (figure 2, item 5).
 6. OPEN the sight glass inlet valve (figure 2, item 1) and the sight glass outlet valve (figure 2, item 2) on the affected sight glass (figure 2, item 3).
 7. CLOSE the WET WELL DRAIN TO HOLDING TANK valve, MSD-13 (figure 1, item 4).
 8. OPEN the WET WELL DISCHARGE valve, MSD-10 (figure 1, item 3).
 9. Remove the lockouts and tagouts (FM 55-502).
 10. Return the MSD to operation under usual conditions (WP 0005 00).
 11. Verify that there are no leaks at the sight glass (figure 2, item 7) on the wet well (figure 2, item 9).
 12. Return the MSD to the desired readiness condition.

END OF WORK PACKAGE

Chapter 6

Unit Maintenance Instructions for Marine Sanitation Device

Inland and Coastal Large Tug (LT)

**UNIT MAINTENANCE
MARINE SANITATION DEVICE FOR
INLAND AND COASTAL LARGE TUG (LT)
MARINE SANITATION DEVICE, REPAIR**

INITIAL SETUP:**Tools and Special Tools:**

Tool Kit, General Mechanic's (Item 1, Table 2, WP 0035 00)

Materials/Parts:

Gloves, Chemical and Oil Protection (Item 1, Table 3, WP 0038 00)

Goggles, Industrial (Item 2, Table 3, WP 0038 00)

Tag, Danger (Item 7, Table 1, WP 0039 00)

Tape, Antiseizing (Item 8, Table 1, WP 0039 00)

Pressure Gauge (Item 4, Figure 1, WP 0037 00)

Personnel Required:

Two Watercraft Engineers, 88L

References:

FM 55-502

TM 55-1925-273-10

References (continued):

WP 0005 00

WP 0035 00

WP 0037 00

WP 0038 00

WP 0039 00

Equipment Conditions:

Set to OFF the MSD DISCHARGE PUMP AND BLOWER circuit breaker (**LT 803 Only**), or the CONTROLLER FOR MSD DISCHARGE PUMP AND BLOWER circuit breaker (**All Other Vessels**) in 440V power panel No. 4. Lock out, and tag out (FM 55-502).

All ventilation systems operating normally (TM 55-1925-273-10).

CLOSE valve CA-81 LP AIR SHUTOFF. Lock out and tag out (FM 55-502).

LOW PRESSURE AIR PRESSURE GAUGE REPLACEMENT**REMOVAL**

Toxic and flammable vapors are generated in the sewage system. Provide ventilation from outside source. Avoid open flames and prolonged breathing of fumes. Failure to comply with warning can result in serious injury to personnel, and damage to equipment.

Sewage is a common mode of transmission for parasitic organisms that may have the capability of causing communicable diseases. After coming in contact with sewage or contaminated equipment, be sure to clean yourself with a disinfectant soap. Avoid sewage contact with skin abrasions, punctures, cuts, and other open wounds. Wipe up and clean any spills and/or contaminated equipment using a disinfectant soap. Failure to comply with this warning can result in serious illness.

1. Use a wrench to loosen and remove the gauge (figure 1, item 1) at the fitting (figure 1, item 2).
2. Cover or plug the remaining open pipe fitting (figure 1, item 2) to prevent contamination from entering the Marine Sanitation Device (MSD) piping.

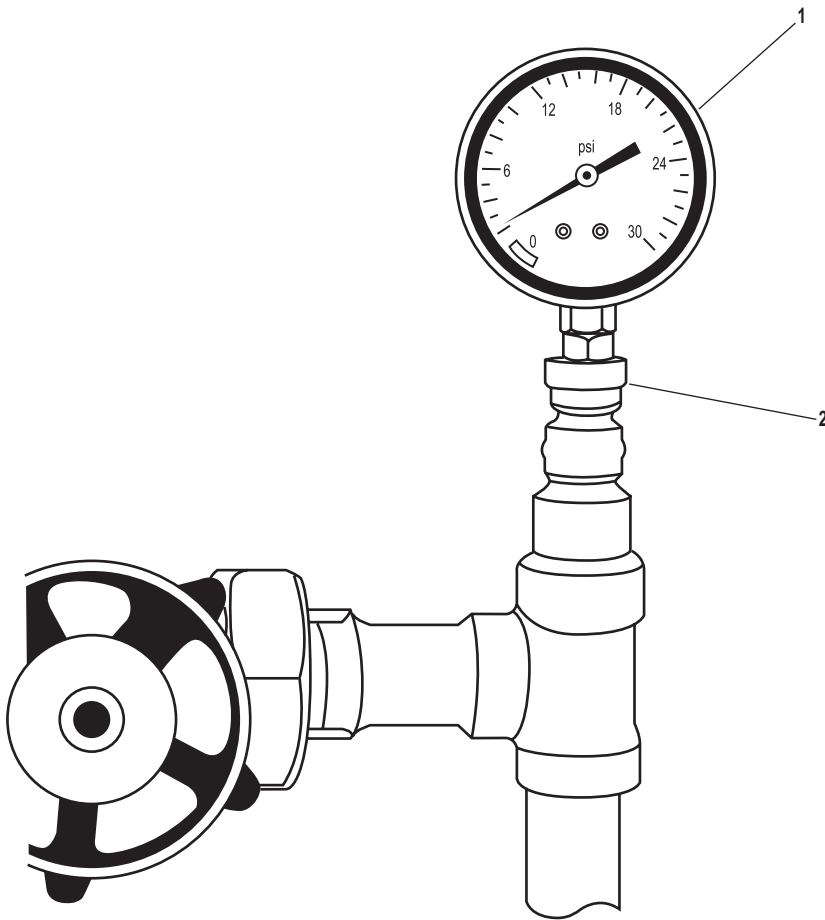

Figure 1. Low Pressure Air Pressure Gauge

INSTALLATION



Removing components by means of wire brushing produces flying particles. These particles can cause serious injury to personnel. Protective goggles, gloves, and long sleeves must be worn at all times during wire brushing operations. Failure to comply with this warning can result in serious injury to personnel.

1. Clean the male threads of the pressure gauge (figure 1, item 1) with a wire brush.
2. Apply antiseizing tape to the male threads of the pressure gauge (figure 1, item 1).
3. Remove the cover or plug from the MSD open pipe fitting (figure 1, item 2).

4. Install the pressure gauge (figure 1, item 1) into the pipe fitting (figure 1, item 2).
5. Remove the lockouts and tagouts (FM 55-502).
6. Return the MSD to normal operation (WP 0005 00).
7. Check for leaks and proper operation. Continue to monitor the system occasionally while the system pressurizes. If leakage is detected, secure the system and stop the leakage.
8. Return the MSD to the desired readiness condition.

END OF WORK PACKAGE

**UNIT MAINTENANCE
MARINE SANITATION DEVICE FOR
INLAND AND COASTAL LARGE TUG (LT)
BLOWER ASSEMBLY, BLOWER; REPLACE**

INITIAL SETUP:**Tools and Special Tools:**

Tool Kit, General Mechanic's (Item 1, Table 2, WP 0035 00)

Materials/Parts:

Dry Cleaning Solvent (Item 5, Table 1, WP 0039 00)
Gloves, Chemical and Oil Protective (Item 1, Table 3, WP 0038 00)
Goggles, Industrial (Item 2, Table 3, WP 0038 00)
Tag, Danger (Item 7, Table 1, WP 0039 00)
Tape, Antiseizing (Item 8, Table 1, WP 0039 00)
Blower (Item 5, Figure 3, WP 0037 00)

Personnel Required:

Two Watercraft Engineers, 88L

References:

FM 55-502
TB 43-0218

References (continued):

TM 55-1925-273-10
WP 0005 00
WP 0016 00
WP 0018 00
WP 0035 00
WP 0037 00
WP 0038 00
WP 0039 00

Equipment Conditions:

Set to OFF MSD DISCHARGE PUMP AND BLOWER circuit breaker (**LT 803 Only**), or the CONTROLLER FOR MSD DISCHARGE PUMP AND BLOWER circuit breaker (**All Other Vessels**) in 440V power panel No. 4. Lock out and tag out (FM 55-502).
All ventilation fans operating normally (TM 55-1925-273-10).
CLOSE valve CA-81 LP AIR SHUTOFF. Lock out and tag out (FM 55-502).

WARNING

Never reuse locking hardware. Reuse of locking hardware such as lockwashers, locking nuts, cotter pins, and lockwire can result in undetected loosening of fastening hardware causing catastrophic component failure resulting in death, injury, or damage to equipment. In accordance with TB 43-0218, ensure that all locking hardware is discarded upon removal and replaced with new.

REMOVAL

1. Perform the Belt Replacement Removal procedure (WP 0016 00).

 **CAUTION**

Failure to use two wrenches while loosening unions, fittings, valves and piping may cause damage to the valves, piping, fittings and unions.

2. Disconnect the blower discharge piping (figure 1, item 1) at the union (figure 1, item 2).
3. Remove the discharge piping (figure 1, item 1) from the check valve (figure 1, item 3).
4. Remove the check valve (figure 1, item 3) from the tee fitting (figure 1, item 4).
5. Remove the relief valve (figure 1, item 5) from the tee fitting (figure 1, item 4).

6. Remove the pressure gauge (figure 1, item 6) from the tee fitting (figure 1, item 4).
7. Perform the Replace Silencer Removal procedure (WP 0018 00).
8. Remove the four nuts (figure 1, item 7) and the four lockwashers (figure 1, item 8) from the studs (figure 1, item 9) that secure the blower (figure 1, item 10). Discard the lockwashers.
9. Remove the blower (figure 1, item 10) from the mounting plate (figure 1, item 11).
10. Remove the tee fitting (figure 1, item 4) and remaining blower discharge fittings (figure 1, item 12) from the blower (figure 1, item 10).

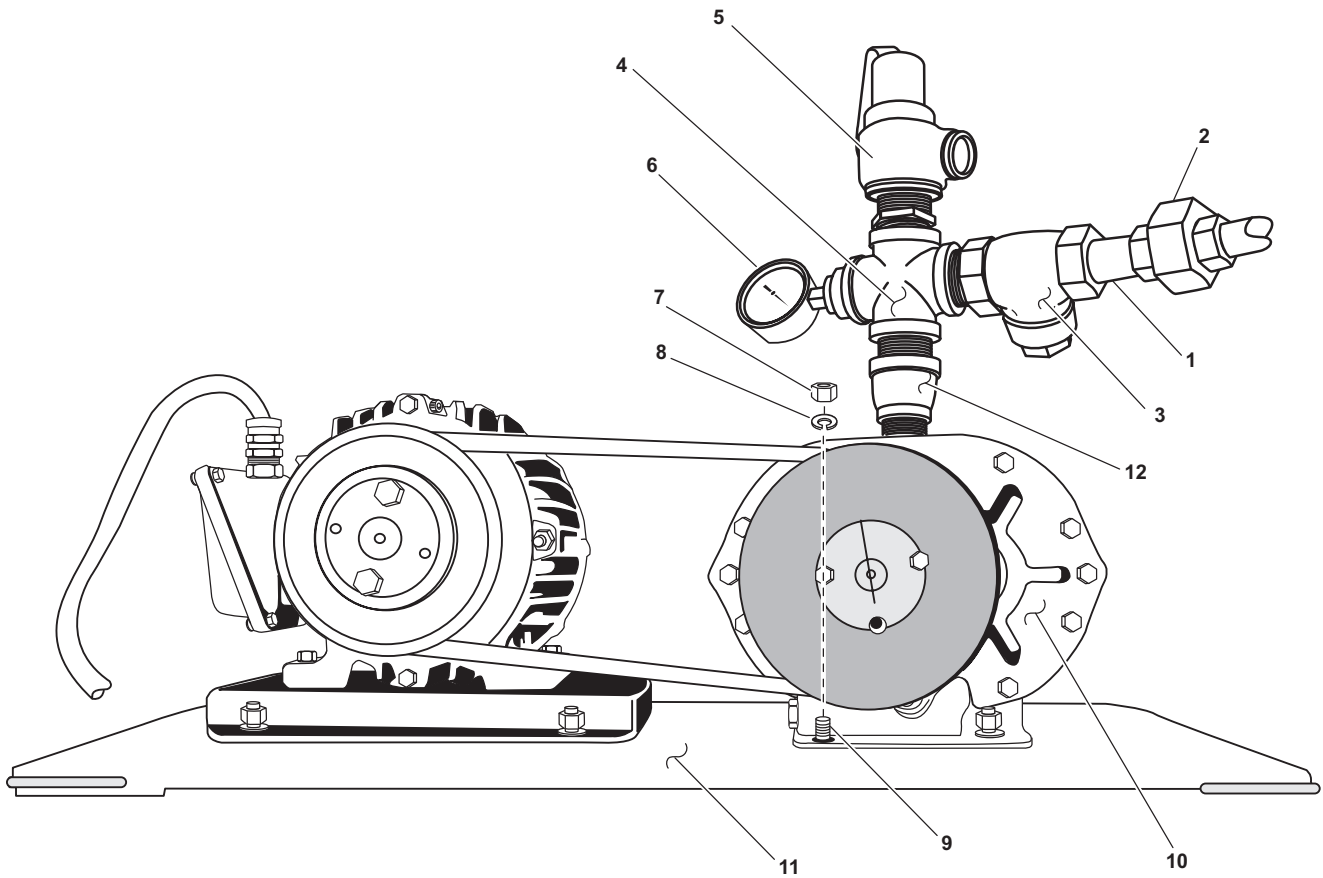
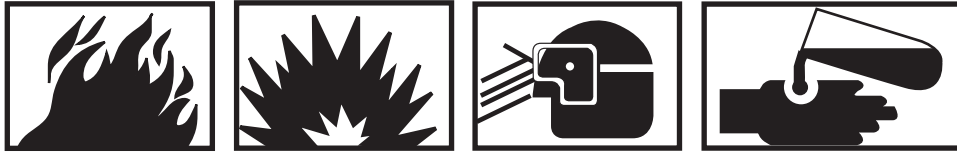

Figure 1. Blower Assembly

INSTALLATION**WARNING**

Cleaning solvent is flammable and its vapor is potentially explosive. Do not use cleaning solvent in the vicinity of spark, open flame, or excessive heat. Do not use cleaning solvent in unventilated spaces. Failure to follow these precautions can result in death or serious injury.

Removing components by means of wire brushing produces flying particles. These particles can cause serious injury to personnel. Protective goggles, gloves, and long sleeves must be worn at all times during wire brushing operations. Failure to comply with this warning can result in serious injury to personnel.

1. Clean all piping, valves and fittings with dry cleaning solvent and a wire brush. Allow all piping, valves, and fittings to air dry before continuing with the procedure.

⚠ CAUTION

Failure to use two wrenches while tightening unions, fittings, valves and piping may cause damage to the valves, piping, fittings and unions.

2. Apply antiseizing tape to all male blower discharge fittings (figure 1, item 12) and install them in the blower (figure 1, item 10).
3. Install the blower (figure 1, item 10) on the mounting plate (figure 1, item 11) and secure it to the studs (figure 1, item 9) with four new lockwashers (figure 1, item 8) and four nuts (figure 1, item 7).
4. Perform the Replace Silencer Installation procedure (WP 0018 00).
5. Apply antiseizing tape to the male threads of the pressure gauge (figure 1, item 6) and install it in the tee fitting (figure 1, item 4).
6. Apply antiseizing tape to the male threads of the relief valve (figure 1, item 5) and install it in the tee fitting (figure 1, item 4).
7. Install the check valve (figure 1, item 3) in the tee fitting (figure 1, item 4).
8. Install the discharge piping (figure 1, item 1) in the check valve (figure 1, item 3).
9. Connect the blower discharge piping (figure 1, item 1) at the union (figure 1, item 2).
10. Perform the Belt Replacement Installation procedure (WP 0016 00).

11. Perform the Angular and Parallel Sheave Alignment procedures (WP 0016 00).
12. Remove the lockouts and tagouts (FM 55-502).
13. Operate the MSD under usual conditions (WP 0005 00).
14. Check the blower for unusual noise or vibration.
15. Return the MSD to the desired readiness condition.

END OF WORK PACKAGE

**UNIT MAINTENANCE
MARINE SANITATION DEVICE FOR
INLAND AND COASTAL LARGE TUG (LT)
BLOWER ASSEMBLY, BLOWER; REPAIR**

INITIAL SETUP:**Tools and Special Tools:**

Tool Kit, General Mechanic's (Item 1, Table 2, WP 0035 00)

Materials/Parts:

Gloves, Chemical and Oil Protective (Item 1, Table 3, WP 0038 00)
Goggles, Industrial, (Item 2, Table 3, WP 0038 00)
Tag, Danger (Item 7, Table 1, WP 0039 00)
Tape, Antiseizing (Item 8, Table 1, WP 0039 00)
Valve, Relief (Item 3, Figure 3, WP 0037 00)

Personnel Required:

Two Watercraft Engineers, 88L

References:

FM 55-502
TM 55-1925-273-10
WP 0005 00
WP 0035 00
WP 0037 00
WP 0038 00
WP 0039 00

Equipment Conditions:

Set to OFF the MSD DISCHARGE PUMP AND BLOWER circuit breaker (**LT 803 Only**), or the CONTROLLER FOR MSD DISCHARGE PUMP AND BLOWER circuit breaker (**All Other Vessels**) in 440V power panel No. 4. Lock out and tag out (FM 55-502).

All ventilation systems operating normally (TM 55-1925-273-10).

BLOWER DISCHARGE PRESSURE RELIEF VALVE REPLACEMENT**REMOVAL****WARNING**

Toxic and flammable vapors are generated in the sewage system. Provide ventilation from outside source. Avoid open flames and prolonged breathing of fumes. Failure to comply with warning can result in serious injury to personnel, and damage to equipment.

Sewage is a common mode of transmission for parasitic organisms that may have the capability of causing communicable diseases. After coming in contact with sewage or contaminated equipment, be sure to clean yourself with a disinfectant soap. Avoid sewage contact with skin abrasions, punctures, cuts, and other open wounds. Wipe up and clean any spills and/or contaminated equipment using a disinfectant soap. Failure to comply with this warning can result in serious illness.

1. Remove the relief valve (figure 1, item 1) from the 90° elbow (figure 1, item 2) by rotating the relief valve until it separates from the piping.
2. Cover or plug the remaining open piping to prevent contamination from entering the Marine Sanitation Device (MSD) piping.

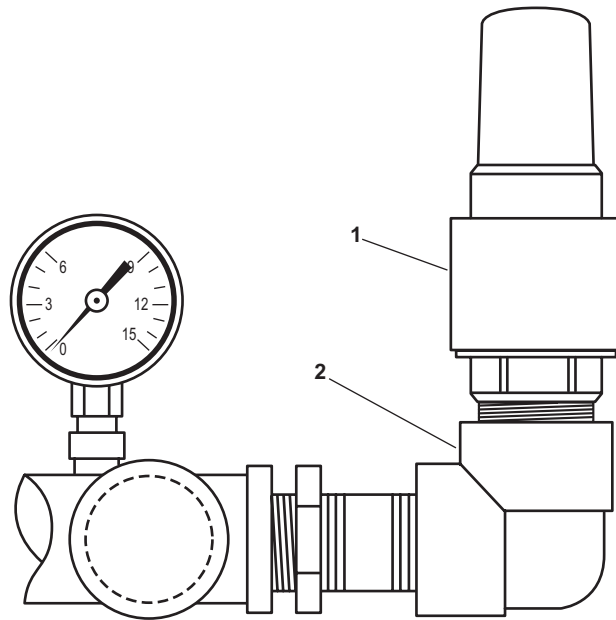

Figure 1. Blower Relief Valve

INSTALLATION



Removing components by means of wire brushing produces flying particles. These particles can cause serious injury to personnel. Protective goggles, gloves, and long sleeves must be worn at all times during wire brushing operations. Failure to comply with this warning can result in serious injury to personnel.

1. Clean the male threads of the relief valve (figure 1, item 1) with a wire brush.
2. Apply antiseizing tape to the male threads of the relief valve (figure 1, item 1).
3. Remove the cover or plug from the MSD open piping.
4. Install the relief valve (figure 1, item 1) into the 90° elbow (figure 1, item 2).
5. Remove the lockouts and tagouts (FM 55-502).
6. Return the MSD to normal operation (WP 0005 00).

7. Check for leaks and proper operation. Continue to monitor the system occasionally while the system pressurizes. If leakage is detected, secure the system and stop the leakage.
8. Return the MSD to the desired readiness condition.

END OF WORK PACKAGE

**UNIT MAINTENANCE
MARINE SANITATION DEVICE FOR
INLAND AND COASTAL LARGE TUG (LT)
BLOWER ASSEMBLY, MOTOR; REPLACE**

INITIAL SETUP:**Tools and Special Tools:**

Tool Kit, General Mechanic's (Item 1, Table 2,
WP 0035 00)
Multimeter (Item 4, Table 2, WP 0035 00)

Materials/Parts:

Tag, Danger (Item 7, Table 1, WP 0039 00)
Motor, AC (Item 1, Figure 3, WP 0037 00)

Personnel Required:

Two Watercraft Engineers, 88L

References:

FM 55-502
TB 43-0218

References (continued):

TM 55-1925-273-10
WP 0005 00
WP 0016 00
WP 0035 00
WP 0037 00
WP 0039 00

Equipment Conditions:

Set to OFF the MSD DISCHARGE PUMP AND BLOWER circuit breaker (**LT 803 Only**), or the CONTROLLER FOR MSD DISCHARGE PUMP AND BLOWER circuit breaker (**All Other Vessels**) in 440V power panel No. 4. Lock out, and tag out (FM 55-502).

All ventilation systems operating normally (TM 55-1925-273-10).

WARNING

Never reuse locking hardware. Reuse of locking hardware such as lockwashers, locking nuts, cotter pins, and lockwire can result in undetected loosening of fastening hardware causing catastrophic component failure resulting in death, injury, or damage to equipment. In accordance with TB 43-0218, ensure that all locking hardware is discarded upon removal and replaced with new.

REMOVAL

1. Perform the Belt Replacement Removal procedure (WP 0016 00).
2. Remove the four screws (figure 1, item 1) from the junction box cover (figure 1, item 2) on the blower assembly motor (figure 1, item 3).
3. Remove the junction box cover (figure 1, item 2) from the blower assembly motor (figure 1, item 3).

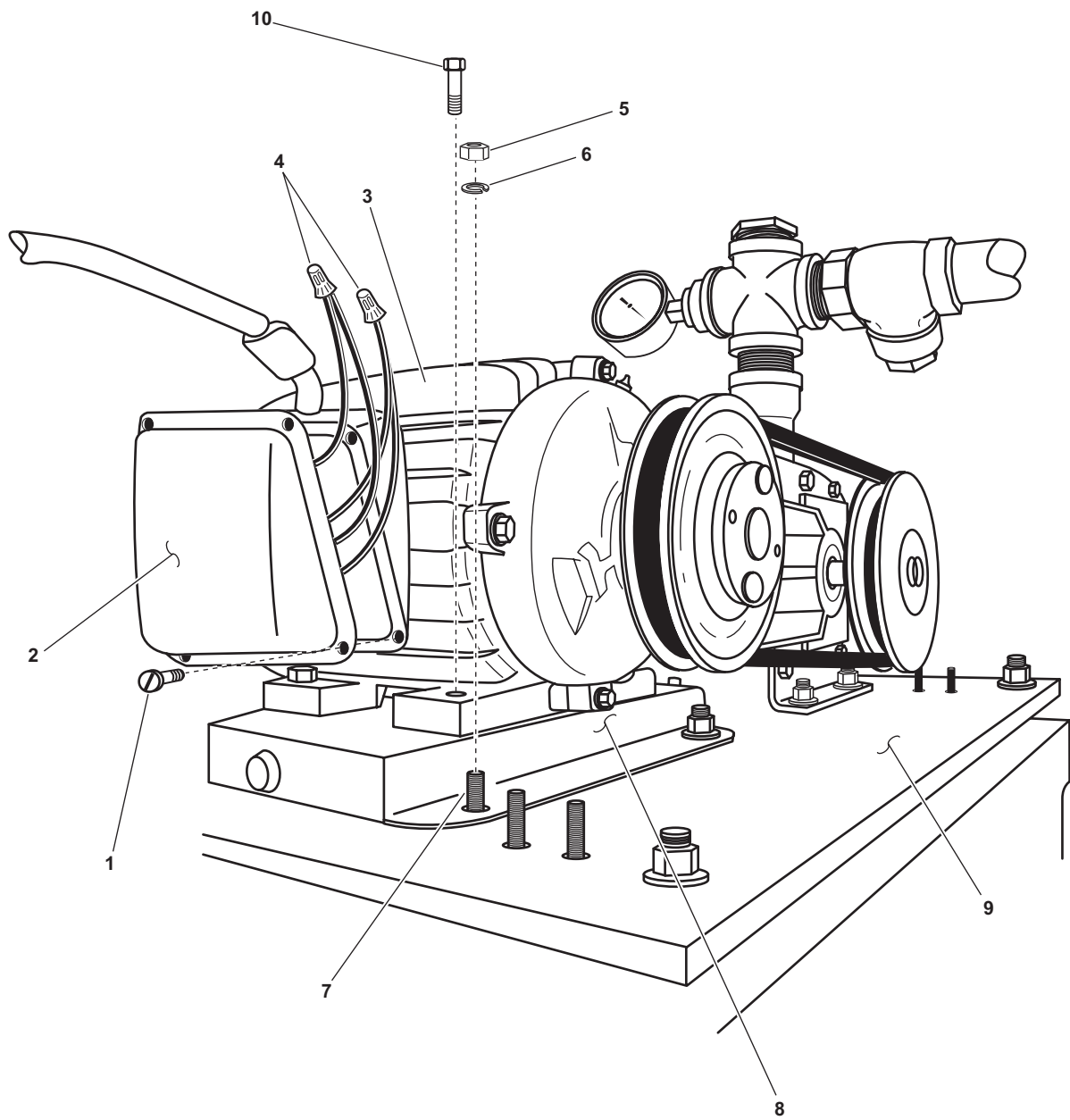

Figure 1. Blower Assembly Motor



Replace or repair components only after the affected circuit has been secured, locked out, and tagged out. Performing replacement with the circuit energized may result in injury.

4. Check for available voltage at the wiring (figure 1, item 4). If voltage is present, ensure that the proper circuit breaker is secured, locked out, and tagged out (FM 55-502). If no voltage is present, continue with the procedure.
5. Label and disconnect the wiring (figure 1, item 4) to the blower assembly motor (figure 1, item 3).
6. Remove the four nuts (figure 1, item 5) and the four lockwashers (figure 1, item 6) from the studs (figure 1, item 7) that secure the blower assembly motor mounting plate (figure 1, item 8) to the foundation (figure 1, item 9). Discard the lockwashers.



Heavy loads can crush. Do not allow any body parts to come under the load or between the load and a stationary object. Death or serious injury can result.

7. Using two crewmembers, remove the blower assembly motor (figure 1, item 3) and the blower assembly motor mounting plate (figure 1, item 8) from the foundation (figure 1, item 9).
8. Remove the four bolts (figure 1, item 10) that secure the blower assembly motor (figure 1, item 3) to the blower assembly mounting plate (figure 1, item 8).



Heavy loads can crush. Do not allow any body parts to come under the load or between the load and a stationary object. Death or serious injury can result.

9. Using two crewmembers, remove the blower assembly motor (figure 1, item 3) from the blower assembly mounting plate (figure 1, item 8).

INSTALLATION

Heavy loads can crush. Do not allow any body parts to come under the load or between the load and a stationary object. Death or serious injury can result.

1. Using two crewmembers, install the blower assembly motor (figure 1, item 3) on the blower assembly mounting plate (figure 1, item 8).

NOTE

The bolts that secure the blower assembly motor will be tightened while performing the parallel and angular sheave alignment procedures.

2. Install the four bolts (figure 1, item 10) that secure the blower assembly motor (figure 1, item 3) to the blower assembly mounting plate (figure 1, item 8). Do not tighten the bolts at this time.



Heavy loads can crush. Do not allow any body parts to come under the load or between the load and a stationary object. Death or serious injury can result.

3. Using two crewmembers, install the blower assembly motor (figure 1, item 3) and the blower assembly motor mounting plate (figure 1, item 8) on its foundation (figure 1, item 9).
4. Install the four nuts (figure 1, item 5) and the four new lockwashers (figure 1, item 6) on the studs (figure 1, item 7) that secure the blower assembly motor mounting plate (figure 1, item 8) to the foundation (figure 1, item 9).
5. Connect the wiring (figure 1, item 4) to the blower assembly motor (figure 1, item 3) using the labels from step 5 of Removal as a guide. Remove the labels.
6. Install the junction box cover (figure 1, item 2) on the blower assembly motor (figure 1, item 3)
7. Install the four screws (figure 1, item 1) in the junction box cover (figure 1, item 2) of the blower assembly motor (figure 1, item 3).
8. Perform the Parallel and Angular Sheave Alignment procedures (WP 0016 00).
9. Perform the Belt Replacement Installation procedure (WP 0016 00).
10. Remove lockouts and tagouts (FM 55-502).

11. Operate the Marine Sanitation Device (MSD) under usual conditions (WP 0005 00).
12. Check the blower assembly motor (figure 1, item 3) for unusual noise and vibration.
13. Return the MSD to the desired readiness state.

END OF WORK PACKAGE

**UNIT MAINTENANCE
MARINE SANITATION DEVICE FOR
INLAND AND COASTAL LARGE TUG (LT)
CHLORINATOR, REPLACE**

INITIAL SETUP:**Tools and Special Tools:**

Tool Kit, General Mechanic's (Item 1, Table 2,
WP 0035 00)
Two Suitable Drain Pans

Materials/Parts:

Gloves, Chemical and Oil Protective (Item 1,
Table 3, WP 0038 00)
Goggles, Industrial (Item 2, Table 3,
WP 0038 00)
Respirator (Item 6, Table 3, WP 0038 00)
Tag, Danger (Item 7, Table 1, WP 0039 00)
Tape, Antiseizing (Item 8, Table 1, WP 0039 00)
Feeder, Tablet (Chlorinator)(Item 1, Figure 4,
WP 0037 00)

Personnel Required:

Two Watercraft Engineers, 88L

References:

FM 55-502
TM 55-1925-273-10
WP 0005 00
WP 0014 00
WP 0035 00
WP 0037 00
WP 0038 00
WP 0039 00

Equipment Conditions:

Set to OFF the MSD DISCHARGE PUMP AND BLOWER circuit breaker (**LT 803 Only**), or the CONTROLLER FOR MSD DISCHARGE PUMP AND BLOWER circuit breaker (**All Other Vessels**) in 440V power panel No. 4. Lock out and tag out (FM 55-502).

All ventilation fans operating normally (TM 55-1925-273-10).

REMOVAL

1. CLOSE the SEWAGE INLET TO MSD valve SD-1 (figure 1, item 1). Lock out and tag out (FM 55-502).
2. OPEN the SEWAGE DRAIN TO HOLDING TANK valve SD-3 (figure 1, item 2).
3. Perform the Clean Chlorinator Feed Tube Removal procedure (WP 0014 00).
4. Place a suitable drain pan under the chlorinator inlet coupling (figure 2, item 1).

WARNING

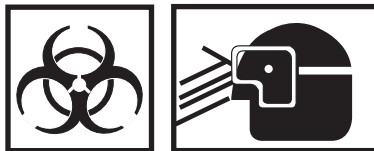

Sewage is a common mode of transmission for parasitic organisms that may have the capability of causing communicable diseases. Protective gloves and a protective apron should be worn to help prevent contact with sewage. After coming in contact with sewage or contaminated equipment, be sure to clean yourself with a disinfectant soap. Avoid sewage contact with skin abrasions, punctures, cuts, and other open wounds. Wipe up and clean any spills and/or contaminated equipment using a disinfectant soap. Failure to comply with this warning may result in serious illness.

5. Loosen the chlorinator inlet coupling (figure 2, item 1) and allow any effluent to drain into the suitable drain pan.

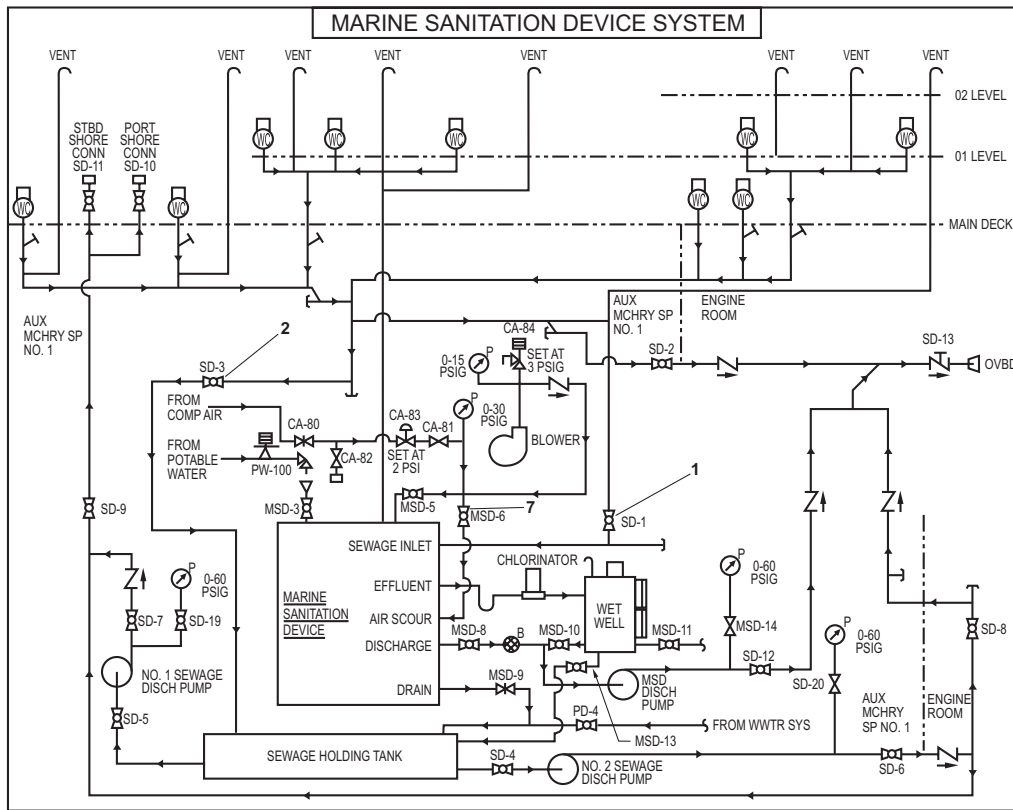

Figure 1. MSD Piping and Valve Schematic

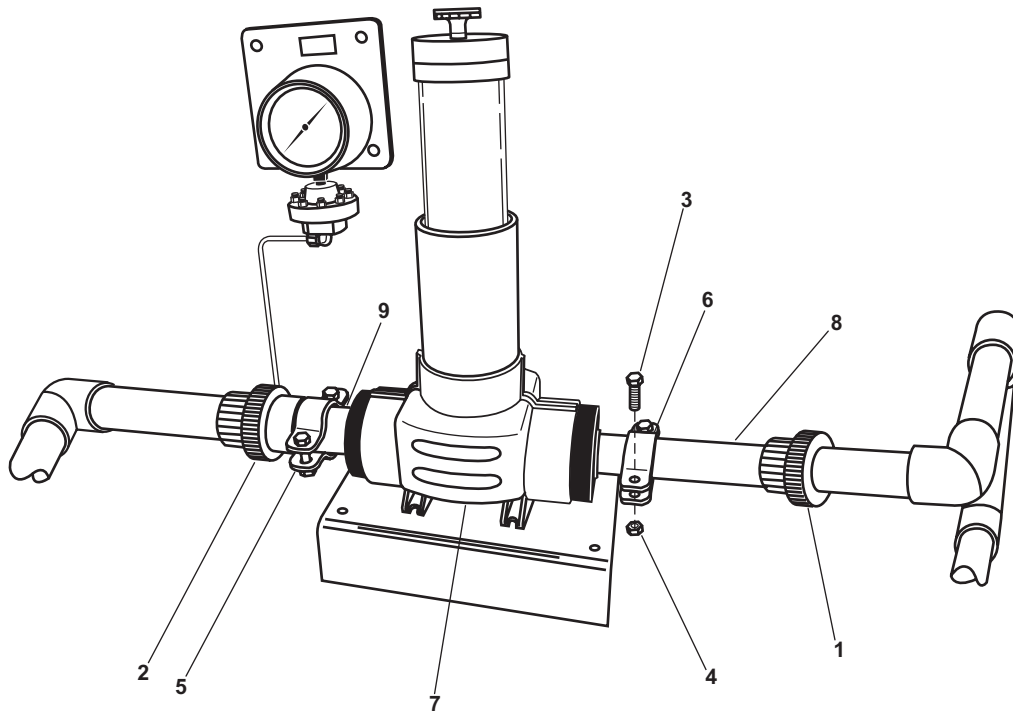

Figure 2. Chlorinator Replacement

6. Place the suitable drain pan under the chlorinator outlet coupling (figure 2, item 2).
7. Loosen the chlorinator outlet coupling (figure 2, item 2) and allow any effluent to drain into the suitable drain pan.
8. Remove the four bolts (figure 2, item 3) and four nuts (figure 2, item 4) from the two chlorinator mounting clamps (figure 2, item 5).
9. Remove the two upper chlorinator mounting clamps (figure 2, item 6).
10. Remove the chlorinator (figure 2, item 7), the chlorinator inlet piping (figure 2, item 8), and the chlorinator outlet piping (figure 2, item 9) as an assembly.
11. Remove the chlorinator inlet piping (figure 2, item 8) and the chlorinator outlet piping (figure 2, item 9) from the chlorinator (figure 2, item 7). Retain the piping for later installation.

INSTALLATION

1. Apply antiseizing tape to the male threads of the chlorinator inlet piping (figure 2, item 8) and the chlorinator outlet piping (figure 2, item 9).
2. Install the chlorinator inlet piping (figure 2, item 8) and the chlorinator outlet piping (figure 2, item 9) in the chlorinator (figure 2, item 7).
3. Install the chlorinator (figure 2, item 7), the chlorinator inlet piping (figure 2, item 8), and the chlorinator outlet piping (figure 2, item 9) on the two lower chlorinator mounting clamps (figure 2, item 5).
4. Install the two upper chlorinator mounting clamps (figure 2, item 6) and secure them in place with the four bolts (figure 2, item 3) and four nuts (figure 2, item 4).
5. Connect the chlorinator inlet coupling (figure 2, item 1) and the chlorinator outlet coupling (figure 2, item 2).
6. Perform the Clean Chlorinator Feed Tube Installation procedure (WP 0014 00).
7. Remove lockouts and tagouts (FM 55-502).
8. CLOSE the SEWAGE DRAIN TO HOLDING TANK valve SD-3 (figure 1, item 2).
9. OPEN the SEWAGE INLET TO MSD valve SD-1 (figure 1, item 1).
10. Operate the Marine Sanitation Device (MSD) under usual conditions (WP 0005 00) and check for leaks.
11. Return the MSD to the desired readiness condition.

END OF WORK PACKAGE

**UNIT MAINTENANCE
MARINE SANITATION DEVICE FOR
INLAND AND COASTAL LARGE TUG (LT)
PUMP ASSEMBLY, REPLACE**

INITIAL SETUP:**Tools and Special Tools:**

Tool Kit, General Mechanic's (Item 1, Table 2, WP 0035 00)
 Tool Kit, Electrician's (Item 2, Table 2, WP 0035 00)
 Multimeter (Item 4, Table 2, WP 0035 00)

References (continued):

TM 55-1925-273-10
 WP 0005 00
 WP 0035 00
 WP 0037 00
 WP 0038 00
 WP 0039 00

Materials/Parts:

Gloves, Chemical and Oil Protective (Item 1, Table 3, WP 0038 00)
 Goggles, Industrial (Item 2, Table 3, WP 0038 00)
 Tag, Danger (Item 7, Table 1, WP 0039 00)
 Tape, Antiseizing (Item 8, Table 1, WP 0039 00)
 Pump, Centrifugal (Item 1, Figure 5, WP 0037 00)

Equipment Conditions:

All ventilation systems operating normally (TM 55-1925-273-10).
 Set to OFF the MSD DISCHARGE PUMP AND BLOWER circuit breaker (**LT 803 Only**), or the CONTROLLER FOR MSD DISCHARGE PUMP AND BLOWER circuit breaker (**All Other Vessels**) in 440V power panel No. 4. Lock out and tag out (FM 55-502).
 CLOSE, lock out, and tag out (FM 55-502) valves MSD-8, MEDIA TANK PUMP-OUT DR; MSD-10, WET WELL DISCHARGE; and SD-12, MSD OVERBOARD DISCH PMP DISCH.

Personnel Required:

Two Watercraft Engineers, 88L

References:

FM 55-502
 TB 43-0218

WARNING

Never reuse locking hardware. Reuse of locking hardware such as lockwashers, locking nuts, cotter pins, and lockwire can result in undetected loosening of fastening hardware causing catastrophic component failure resulting in death, injury, or damage to equipment. In accordance with TB 43-0218, ensure that all locking hardware is discarded upon removal and replaced with new.

DISCHARGE PUMP AND MOTOR ASSEMBLY REPLACEMENT**REMOVAL**

1. Remove the four screws (figure 1, item 1) and remove the junction box cover (figure 1, item 2) from the junction box (figure 1, item 3).

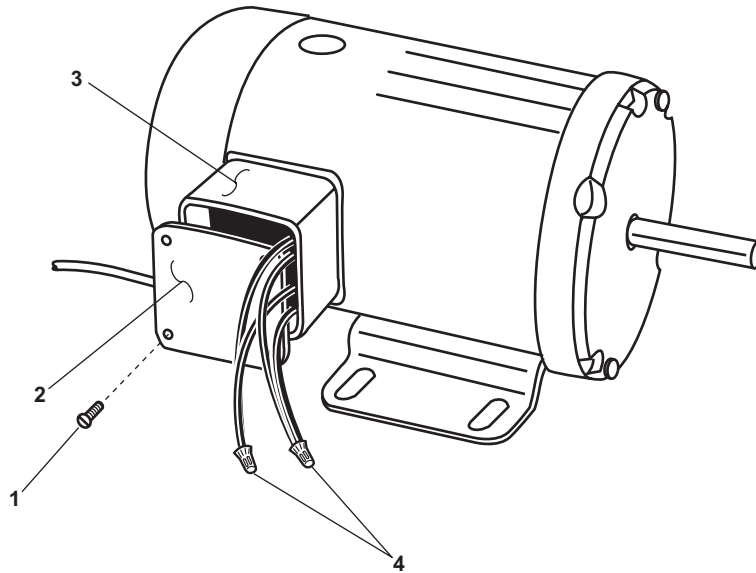

Figure 1. Pump Motor and Junction Box



Replace or repair components only after the affected circuit has been secured, locked out, and tagged out. Performing replacement with the circuit energized may result in injury.

2. Use a multimeter to check for voltage at the wiring (figure 1, item 4). If voltage is present, ensure that the proper circuit breaker is secured, locked out, and tagged out (FM 55-502). If no voltage is present, continue with the procedure.
3. Label, disconnect, and remove the wiring (figure 1, item 4) from the junction box (figure 1, item 3).

WARNING

Toxic and flammable vapors are generated in the sewage system. Provide ventilation from outside source. Avoid open flames and prolonged breathing of fumes. Failure to comply with this warning can result in serious injury to personnel and damage to the vessel.

Sewage is a common mode of transmission for parasitic organisms that may have the capability of causing communicable diseases. After coming in contact with sewage or contaminated equipment, be sure to clean yourself with a disinfectant soap. Avoid sewage contact with skin abrasions, punctures, cuts, and other open wounds. Wipe up and clean any spills and/or contaminated equipment using a disinfectant soap. Failure to comply with this warning can result in serious illness.

⚠ CAUTION

Never attempt to disconnect union connections with only one wrench. Damage to the vessel's standing piping could occur. Always use the two wrench method to disconnect piping unions.

4. Disconnect the inlet union (figure 2, item 1) and outlet union (figure 2, item 2) from the pump (figure 2, item 3) using the two wrench method.
5. Remove the four bolts (figure 2, item 4), four nuts (figure 2, item 5), and four lockwashers (figure 2, item 6) that secure the motor (figure 2, item 7) to the mounting plate (figure 2, item 8). Discard the lockwashers.
6. Remove the entire Marine Sanitation Device (MSD) discharge pump (figure 2, item 3) and attached motor (figure 2, item 7) to a suitable work area.
7. Disconnect the inlet fitting (figure 2, item 9) and outlet fitting (figure 2, item 10) from the pump (figure 2, item 3).

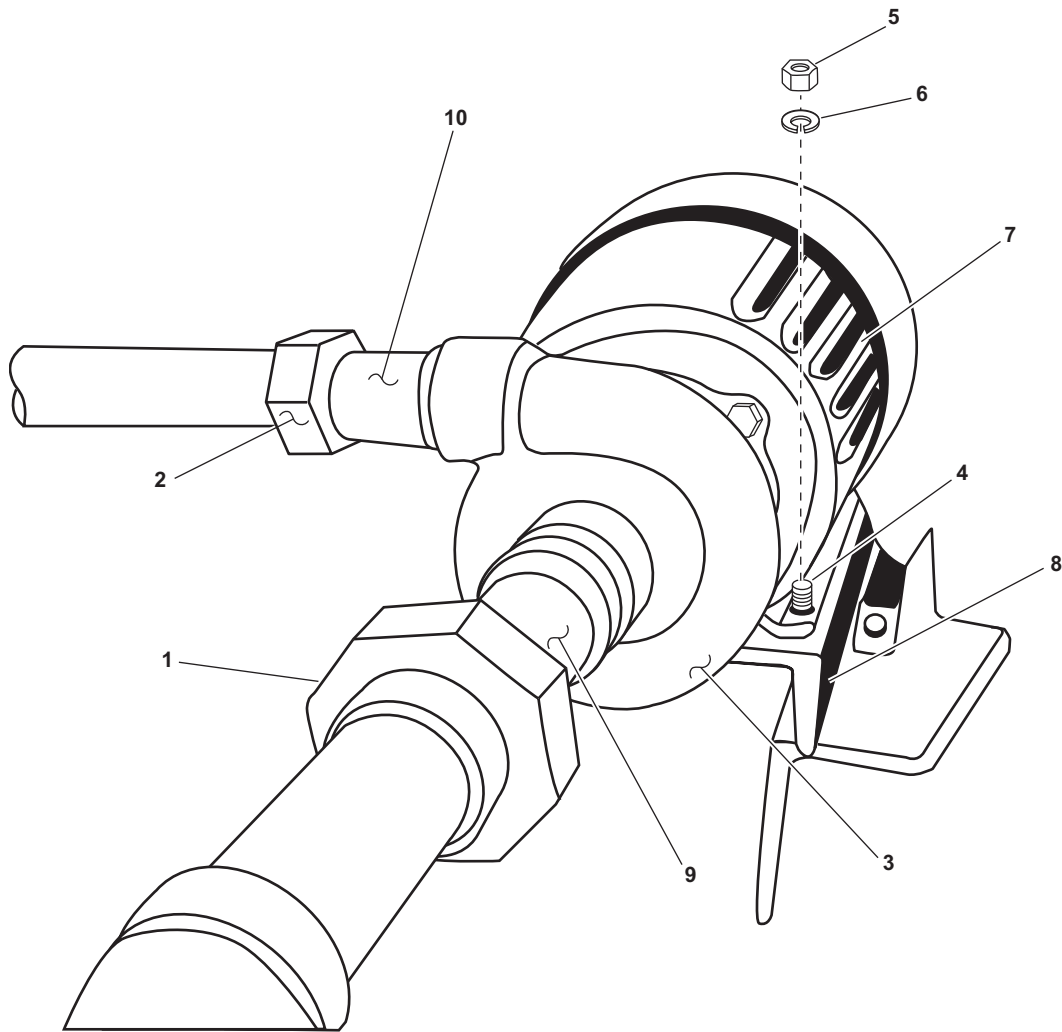

Figure 2. MSD Discharge Pump, Fittings, and Fasteners

INSTALLATION



Removing components by means of wire brushing produces flying particles. These particles can cause serious injury to personnel. Protective goggles, gloves, and long sleeves must be worn at all times during wire brushing operations. Failure to comply with this warning can result in serious injury to personnel.

1. Clean the male pipe threads of the inlet fitting (figure 2, item 9) and outlet fitting (figure 2, item 10) with a wire brush.
2. Wrap the male pipe threads with of the inlet fitting (figure 2, item 9) and outlet fitting (figure 2, item 10) with antiseizing tape.

3. Install the inlet fitting (figure 2, item 9) and outlet fitting (figure 2, item 10) on the pump (figure 2, item 3).
4. Position the entire MSD discharge pump (figure 2, item 3) and attached motor (figure 2, item 7) on the mounting plate (figure 2, item 8).

 **CAUTION**

Never attempt to connect union connections with only one wrench. Damage to the vessel's standing piping could occur. Always use two wrenches.

5. Tighten the inlet union (figure 2, item 1) and outlet union (figure 2, item 2) on the pump (figure 2, item 3) using the two wrench method.
6. Secure the MSD discharge pump (figure 2, item 3) and attached motor (figure 2, item 7) to the mounting plate (figure 2, item 8) with the four bolts (figure 2, item 4), four nuts (figure 2, item 5), and four new lockwashers (figure 2, item 6).
7. Install and connect the wiring (figure 1, item 4) in the junction box (figure 1, item 3), using the labels from step 3 in Removal as a guide. Remove the labels.
8. Install the junction box cover (figure 1, item 2) on the junction box (figure 1, item 3) using the four screws (figure 1, item 1).
9. Remove the lockouts and tagouts (FM 55-502).
10. Return the MSD to normal operation (WP 0005 00).
11. Check for leaks and proper operation.
12. Return the MSD to the desired readiness condition.

END OF WORK PACKAGE

**UNIT MAINTENANCE
MARINE SANITATION DEVICE FOR
INLAND AND COASTAL LARGE TUG (LT)
PUMP ASSEMBLY, REPAIR**

INITIAL SETUP:**Tools and Special Tools:**

Tool Kit, General Mechanic's (Item 1, Table 2,
WP 0035 00)

References:

TB 43-0218
WP 0025 00
WP 0035 00
WP 0037 00

Materials/Parts:

Motor, AC, 1.5 hp (Item 2, Figure 5,
WP 0037 00)
Pump, Centrifugal (Item 1, Figure 5,
WP 0037 00)

Equipment Conditions:

MSD discharge pump and motor removed
(WP 0025 00).

Personnel Required:

One Watercraft Engineer, 88L

WARNING

Never reuse locking hardware. Reuse of locking hardware such as lockwashers, locking nuts, cotter pins, and lockwire can result in undetected loosening of fastening hardware causing catastrophic component failure resulting in death, injury, or damage to equipment. In accordance with TB 43-0218, ensure that all locking hardware is discarded upon removal and replaced with new.

DISASSEMBLY**NOTE**

It may be necessary to rotate the motor shaft by hand to gain access to the capscrews.

1. Loosen, but do not remove, the two exposed capscrews (figure 1, item 1).
2. Remove the four bolts (figure 1, item 2) and four lockwashers (figure 1, item 3) that secure the pump (figure 1, item 4) to the motor (figure 1, item 5). Discard the lockwashers.
3. Remove the pump (figure 1, item 4) from the motor (figure 1, item 5).

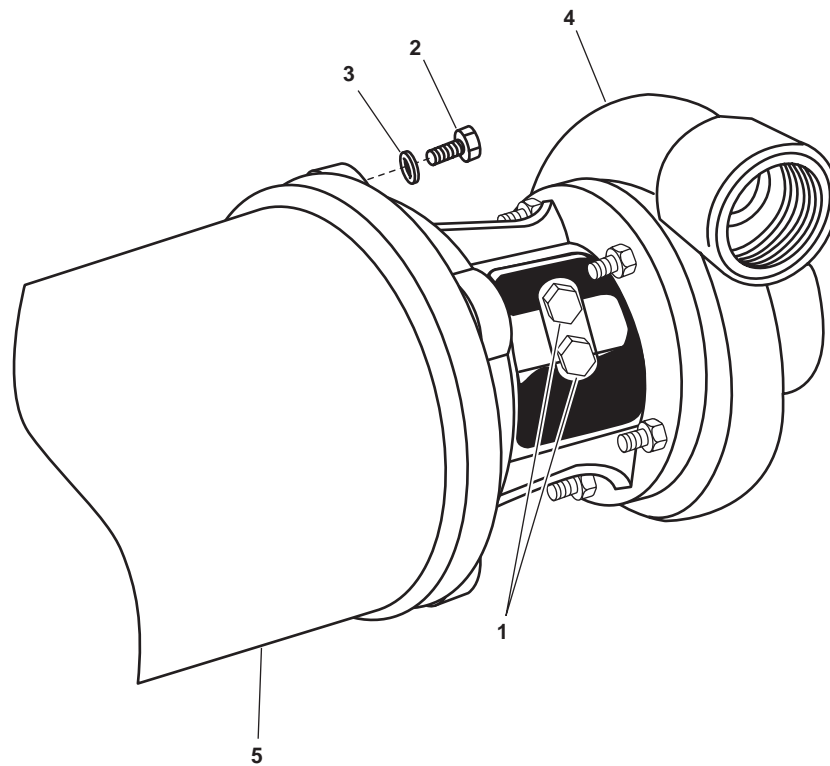

Figure 1. Pump Assembly

ASSEMBLY

1. Install the pump (figure 1, item 4) on the motor (figure 1, item 5) using four bolts (figure 1, item 2) and four new lockwashers (figure 1, item 3).
2. Tighten the two exposed capscrews (figure 1, item 1).
3. Install the MSD discharge pump and motor (WP 0025 00).
4. Operate the MSD discharge pump under usual conditions (WP 0005 00) and check for proper operation.
5. Return the MSD discharge pump to the desired readiness condition.

END OF WORK PACKAGE

Chapter 7

Direct Support Maintenance Instructions for Marine Sanitation Device

Inland and Coastal Large Tug (LT)

**DIRECT SUPPORT MAINTENANCE
MARINE SANITATION DEVICE FOR
INLAND AND COASTAL LARGE TUG (LT)
MARINE SANITATION DEVICE, REPAIR**

INITIAL SETUP:**Tools and Special Tools:**

Tool Kit, General Mechanic's (Item 1, Table 2, WP 0035 00)
Wrench, Pipe 18 Inch (Item 7, Table 2, WP 0035 00)
Suitable Drain Pan

References:

FM 55-502
TM 55-1925-273-10
WP 0005 00
WP 0035 00
WP 0038 00
WP 0039 00

Materials/Parts:

Gloves, Chemical and Oil Protective (Item 1, Table 3, WP 0038 00)
Goggles, Industrial (Item 2, Table 3, WP 0038 00)
Respirator (Item 6, Table 3, WP 0038 00)
Tag, Danger (Item 7, Table 1, WP 0039 00)
Tape, Antiseizing (Item 8, Table 1 WP 0039 00)

Equipment Conditions:

CLOSE all valves upstream and downstream of the affected valve. Lock out and tag out (FM 55-502).
All ventilation fans operating normally (TM 55-1925-273-10).

Personnel Required:

Two Watercraft Engineers, 88L

NOTE

The valve replacement procedures in this work package are for typical valves found on the Marine Sanitation Device (MSD). Actual removal and installation of the valves in this work package may differ slightly from the procedures as written.

THREADED GATE VALVE**REMOVAL**

1. Place a suitable drain pan under the union (figure 1, item 1) of the threaded gate valve (figure 1, item 2) to be removed.

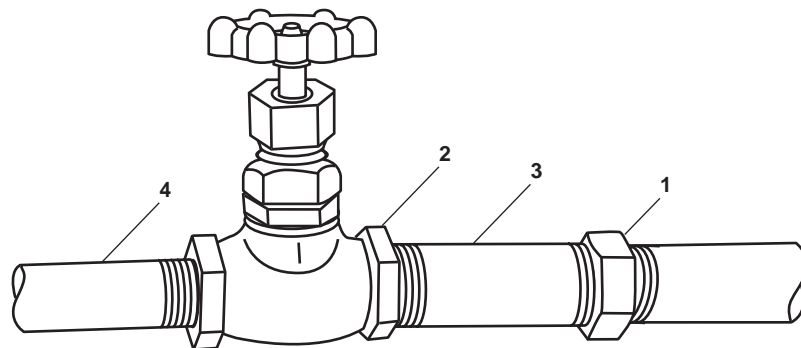
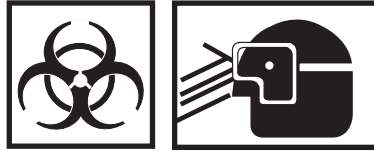

Figure 1. Threaded Gate Valve

WARNING

Sewage is a common mode of transmission for parasitic organisms that may have the capability of causing communicable diseases. After coming in contact with sewage or contaminated equipment, be sure to clean yourself with a disinfectant soap. Avoid sewage contact with skin abrasions, punctures, cuts, and other open wounds. Wipe up and clean any spills and/or contaminated equipment using a disinfectant soap.

⚠ CAUTION

Failure to use two wrenches while loosening pipe fittings, couplings, and valves may cause damage to the valves, fittings, couplings, and piping.

2. Using a pipe wrench, loosen the union (figure 1, item 1) and allow any effluent to drain into the suitable drain pan.
3. Remove the pipe (figure 1, item 3) from the threaded gate valve (figure 1, item 2).
4. Remove the threaded gate valve (figure 1, item 2) from the remaining piping (figure 1, item 4).

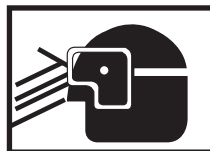
INSTALLATION**WARNING**

Removing components by means of wire brushing produces flying particles. These particles can cause serious injury to personnel. Protective goggles, gloves, and long sleeves must be worn at all times during wire brushing operations. Failure to comply with this warning can result in serious injury to personnel.

1. Clean the threaded ends of the piping (figure 1, items 3 and 4) with a wire brush and apply antiseizing tape to the threaded ends of the piping.

⚠ CAUTION

Failure to use two wrenches while tightening pipe fittings, couplings, and valves may cause damage to the valves, fittings, couplings, and piping.

2. Install the threaded gate valve (figure 1, item 2) onto the existing piping (figure 1, item 4).
3. Install the pipe (figure 1, item 3) into the threaded gate valve (figure 1, item 2).

4. Connect the union (figure 1, item 1).
5. Perform the Follow-On Service procedure at the end of this work package.

FLANGED GATE VALVE

REMOVAL

1. Place a suitable drain pan under the flanged gate valve (figure 2, item 1) to be removed.

WARNING



Sewage is a common mode of transmission for parasitic organisms that may have the capability of causing communicable diseases. After coming in contact with sewage or contaminated equipment, be sure to clean yourself with a disinfectant soap. Avoid sewage contact with skin abrasions, punctures, cuts, and other open wounds. Wipe up and clean any spills and/or contaminated equipment using a disinfectant soap.

2. Loosen, but do not remove, the eight bolts (figure 2, item 2) and eight nuts (figure 2, item 3) on the flanged gate valve (figure 2, item 1) and allow any effluent to drain into the suitable drain pan.

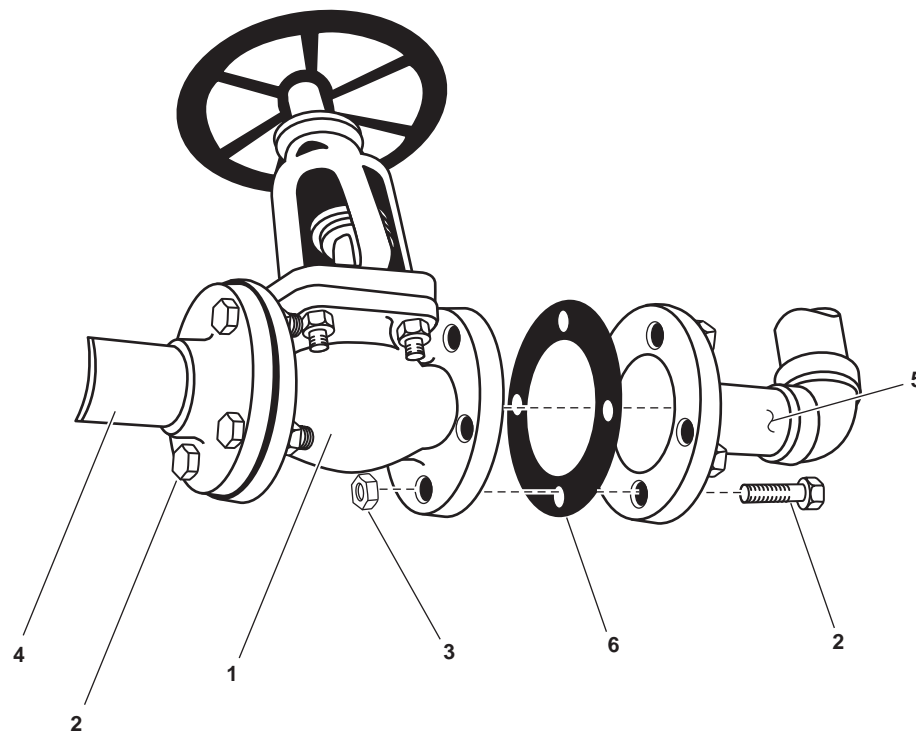
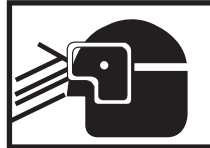

Figure 2. Flanged Gate Valve

3. Remove the eight bolts (figure 2, item 2) and eight nuts (figure 2, item 3) from the flanged gate valve (figure 2, item 1).
4. Remove the flanged gate valve (figure 2, item 1) from the piping (figure 2, items 4 and 5).
5. Remove the gaskets (figure 2, item 6) from the piping (figure 2, items 4 and 5). Discard the gaskets.

INSTALLATION

WARNING



Removing components by means of wire brushing produces flying particles. These particles can cause serious injury to personnel. Protective goggles, gloves, and long sleeves must be worn at all times during wire brushing operations. Failure to comply with this warning can result in serious injury to personnel.

1. Clean the flanged ends of the piping (figure 2, items 4 and 5) with a wire brush.
2. Position the flanged gate valve (figure 2, item 1) between the piping (figure 2, items 4 and 5). Install the new gaskets (figure 2, item 6) and secure the flanged gate valve in place with the eight bolts (figure 2, item 2) and the eight nuts (figure 2, item 3).
3. Perform the Follow-On Service procedure at the end of this work package.

FOLLOW-ON SERVICE

1. Remove the lockouts and tagouts (FM 55-502).
2. Return the MSD to operation under usual conditions (WP 0005 00) and check for leaks at the replaced valve.
3. Return the MSD to the desired readiness condition.

END OF WORK PACKAGE

**DIRECT SUPPORT MAINTENANCE
MARINE SANITATION DEVICE FOR
INLAND AND COASTAL LARGE TUG (LT)
CONTROLLER, REPAIR**

INITIAL SETUP:**Tools and Special Tools:**

Tool Kit, Electrician's (Item 2, Table 2,
WP 0035 00)
Multimeter (Item 6, Table 2, WP 0035 00)

References:

FM 55-502
WP 0005 00
WP 0035 00
WP 0039 00

Materials/Parts:

Tag, Danger (Item 7, Table 1, WP 0039 00)

Equipment Conditions:

Set to OFF the MSD DISCHARGE AND BLOWER circuit breaker (**LT 803 Only**), or the CONTROLLER FOR MSD DISCHARGE PUMP AND BLOWER circuit breaker (**All Other Vessels**) in 440V power panel No. 4. Lock out and tag out (FM 55-502).

Personnel Required:

Two Watercraft Engineers, 88L

OPEN THE CONTROLLER

1. Loosen the nine captive retaining screws (figure 1, item 1) that secure the controller door (figure 1, item 2).

NOTE

The controller door cannot be opened unless the handle is in the RESET position.

2. Place the handle (figure 1, item 3) in the RESET position.

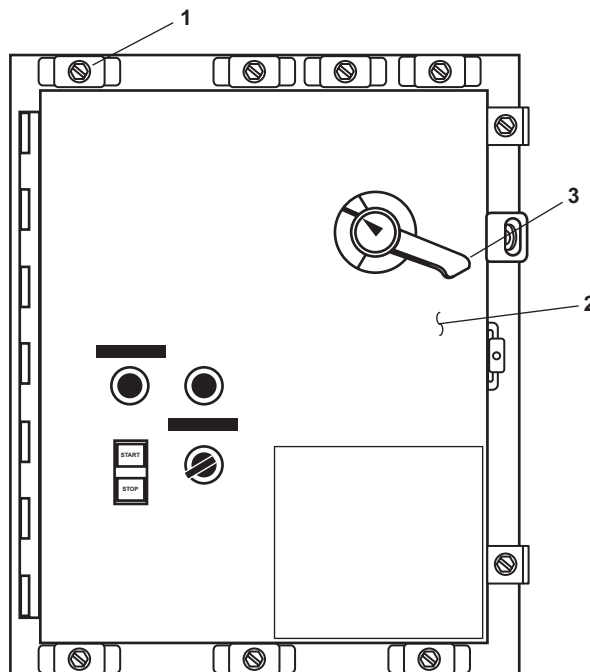

Figure 1. Controller

3. Open the controller door (figure 1, item 2).



Replace or repair components only after the affected circuit has been secured, locked out, and tagged out. Performing replacement with the circuit energized may result in injury.

4. Use a multimeter to check for voltage at the line side (figure 2, item 1) of the interrupt contactor (figure 2, item 2). If voltage is present, ensure that the proper breaker is secured, locked out, and tagged out (FM 55-502). If no voltage is present, continue with the appropriate repair procedure below.

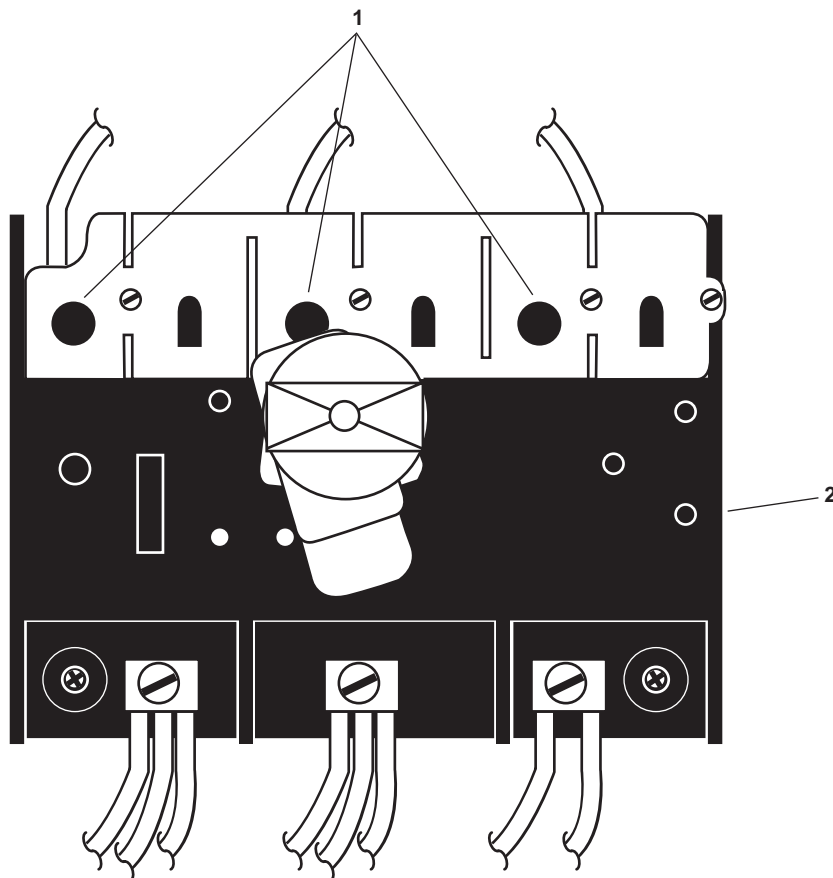

Figure 2. MSD Interrupt Contactor

ROTARY SWITCH REPLACEMENT

REMOVAL

1. Perform the Open the Controller procedure at the beginning of this work package.
2. Unscrew the retaining ring (figure 3, item 1) and pull off the knob (figure 3, item 2).
3. Label and disconnect the wiring (figure 3, item 3) from the contactor (figure 3, item 4).
4. Lift the locking tab (figure 3, item 5) slightly and disconnect the contactor (figure 3, item 4) from the actuator (figure 3, item 6).
5. Remove the retaining nut (figure 3, item 7) and remove the actuator (figure 3, item 6) from the door (figure 3, item 8).

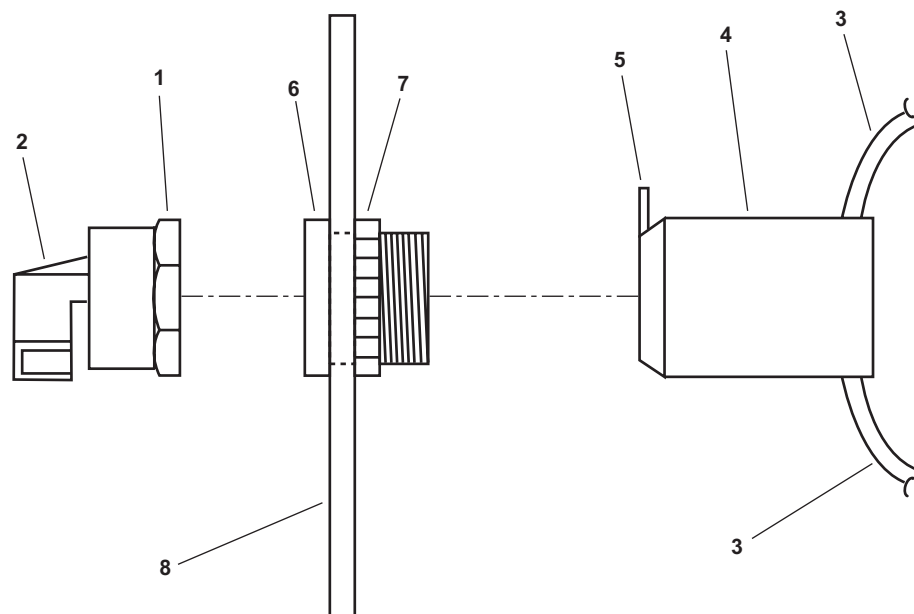

Figure 3. Rotary Switch Replacement

INSTALLATION

1. Install the actuator (figure 3, item 6) in the door (figure 3, item 8) and secure it with the retaining nut (figure 3, item 7).
2. Install the contactor (figure 3, item 4) on the actuator (figure 3, item 6) with the locking tab (figure 3, item 5) facing upward.
3. Connect the wiring (figure 3, item 3) to the contactor (figure 3, item 4) using the labels from step 3 in Removal as a guide. Remove the labels.
4. Install the knob (figure 3, item 2) on the actuator (figure 3, item 6) and secure it with the retaining ring (figure 3, item 1).
5. Perform the Follow-On Service procedure at the end of this work package.

HANDLE REPLACEMENT**REMOVAL**

1. Perform the Open the Controller procedure at the beginning of this work package.
2. Remove the three screws (figure 4, item 1) securing the retaining ring (figure 4, item 2) and remove the retaining ring.
3. Remove the handle (figure 4, item 3) from the enclosure door (figure 4, item 4).

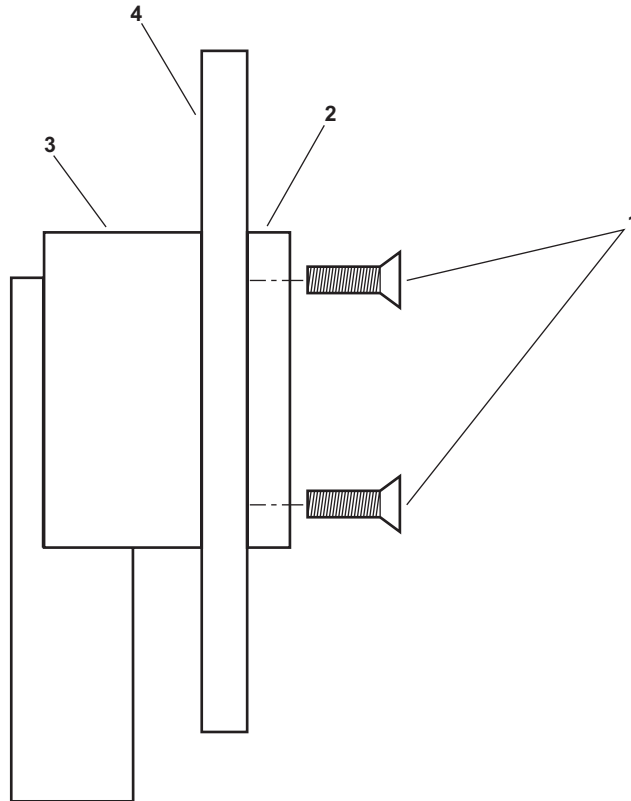

Figure 4. Handle Replacement

INSTALLATION

1. Position the handle (figure 4, item 3) in the enclosure door (figure 4, item 4).
2. Secure the handle (figure 4, item 3) with the retaining ring (figure 4, item 2) and three screws (figure 4, item 1).
3. Perform the Follow-On Service procedure at the end of this work package.

PUSHBUTTON SWITCH REPLACEMENT

REMOVAL

1. Perform the Open the Controller procedure at the beginning of this work package.
2. Label and disconnect the wiring (figure 5, item 1) from the contactor (figure 5, item 2).
3. Lift the locking tab (figure 5, item 3) slightly and pull the contactor (figure 5, item 2) off the pushbutton switch (figure 5, item 4).
4. Remove the retaining nut (figure 5, item 5) that secures the pushbutton switch (figure 5, item 4) to the door (figure 5, item 6) and remove the pushbutton switch.

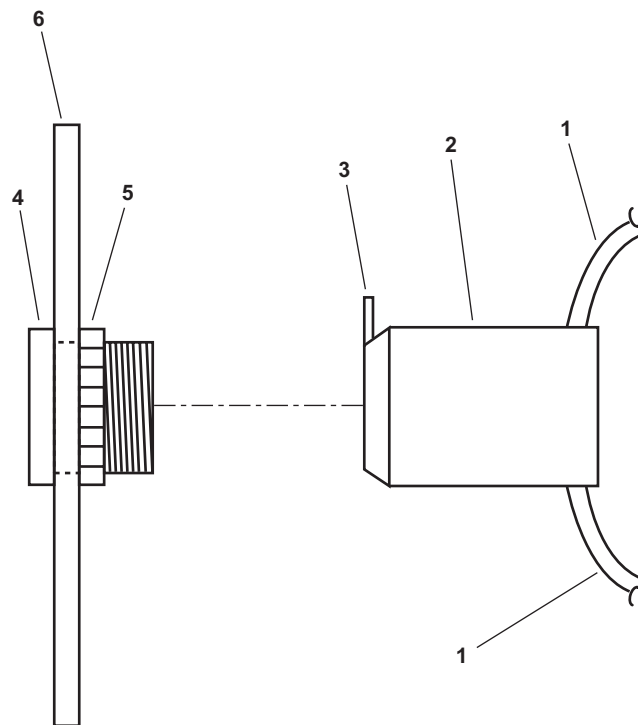

Figure 5. Pushbutton Switch Replacement

INSTALLATION

1. Install the pushbutton switch (figure 5, item 4) in the door (figure 5, item 6) and secure it with the retaining nut (figure 5, item 5).
2. Snap the contactor (figure 5, item 2) into place on the pushbutton switch (figure 5, item 4) with the locking tab (figure 5, item 3) facing upward.
3. Connect the wiring (figure 5, item 1) to the contactor (figure 5, item 2) using the labels from step 2 of Removal as a guide. Remove the labels.
4. Perform the Follow-On Service procedure at the end of this work package.

THERMAL RELAY REPLACEMENT

REMOVAL

1. Perform the Open the Controller procedure at the beginning of this work package.

NOTE

The left magnetic contactor/thermal relay assembly is for the MSD discharge pump.
The right magnetic contactor/thermal relay assembly is for the blower. The units may be replaced singly.

2. Label and disconnect the wiring (figure 6, item 1) on the load side of the thermal relay (figure 6, item 2).
3. Loosen the clamping screws (figure 6, item 3) on the load side of the magnetic contactor (figure 6, item 4) that secure the line leads (figure 6, item 5).
4. Allow the front side of the thermal relay (figure 6, item 2) to drop down and lift the rear of the thermal relay to remove it from the magnetic contactor (figure 6, item 4).

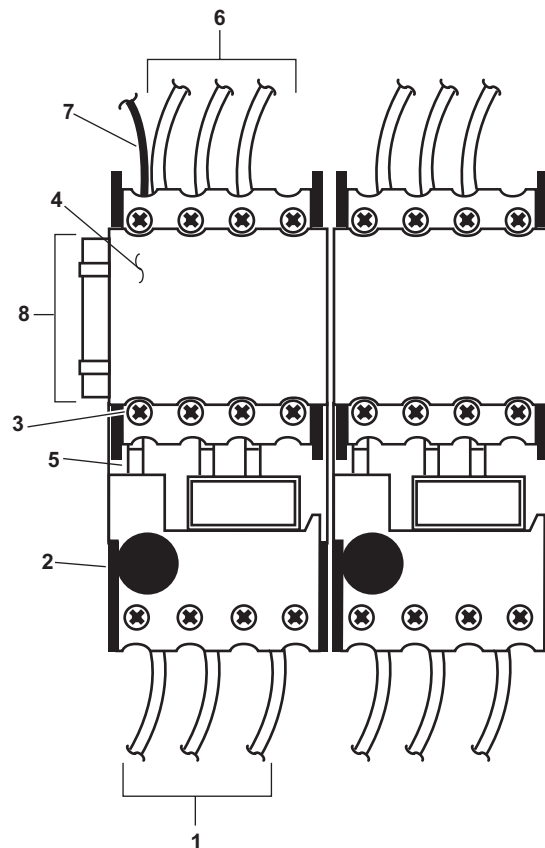

Figure 6. Thermal Relay Replacement

INSTALLATION

1. Position the rear of the thermal relay (figure 6, item 2) into the retaining slot in the magnetic contactor (figure 6, item 4).
2. Lift the front of the thermal relay (figure 6, item 2) and guide its line side leads (figure 6, item 5) into the clamping screws (figure 6, item 3) on the magnetic contactor (figure 6, item 4).
3. Secure the line side leads (figure 6, item 5) by tightening the clamping screws (figure 6, item 3).
4. Connect the load side wiring (figure 6, item 1) using the labels from step 2 of Removal as a guide. Remove the labels.
5. Perform the Follow-On Service procedure at the end of this work package.

MAGNETIC CONTACTOR REPLACEMENT**NOTE**

The left magnetic contactor/thermal relay assembly is for the MSD discharge pump. The right magnetic contactor/thermal relay assembly is for the blower. The units may be replaced singly.

REMOVAL

1. Perform the Replace Thermal Relay Removal procedure in this work package.
2. Label and disconnect the wiring (figure 6, item 6) from the line side of the magnetic contactor (figure 6, item 4) and from the ground (figure 6, item 7).
3. Slide the magnetic contactor (figure 6, item 4) sideways to remove it from the mounting rail (figure 6, item 8).

INSTALLATION

1. Slide the magnetic contactor (figure 6, item 4) onto the mounting rail (figure 6, item 8).
2. Connect the wiring (figure 6, items 6 and 7) using the labels from step 2 of Removal as a guide. Remove the labels.
3. Perform the Follow-On Service procedure at the end of this work package.

TRANSFORMER REPLACEMENT**REMOVAL**

1. Perform the Open the Controller procedure at the beginning of this work package.
2. Label and disconnect the wiring (figure 7, item 1) from the transformer (figure 7, item 2).
3. Remove the four mounting screws (figure 7, item 3) and remove the transformer (figure 7, item 2).

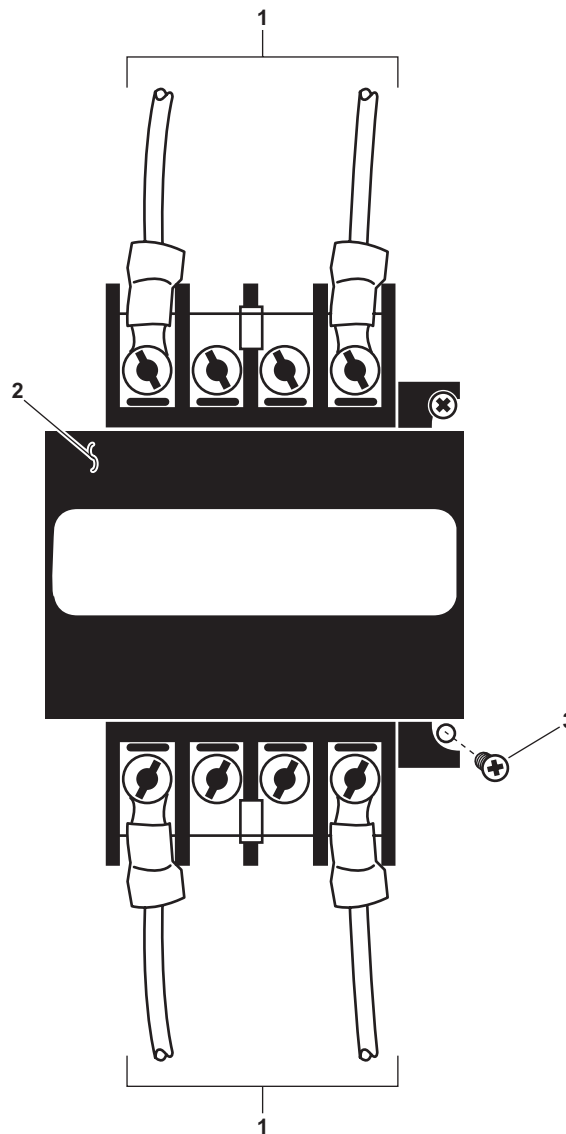

Figure 7. Transformer Replacement

INSTALLATION

1. Position the transformer (figure 7, item 2) in the enclosure and secure it with the four mounting screws (figure 7, item 3).
2. Connect the wiring (figure 7, item 1) to the transformer (figure 7, item 2) using the labels from step 2 of Removal as a guide. Remove the labels.
3. Perform the Follow-On Service procedure at the end of this work package.

INTERRUPT CONTACTOR REPLACEMENT

REMOVAL

1. Perform the Open the Controller procedure at the beginning of this work package.
2. Label and disconnect the wiring (figure 8, item 1).
3. Remove the four mounting screws (figure 8, item 2) securing the interrupt contactor (figure 8, item 3).
4. Remove the interrupt contactor (figure 8, item 3) from the enclosure.

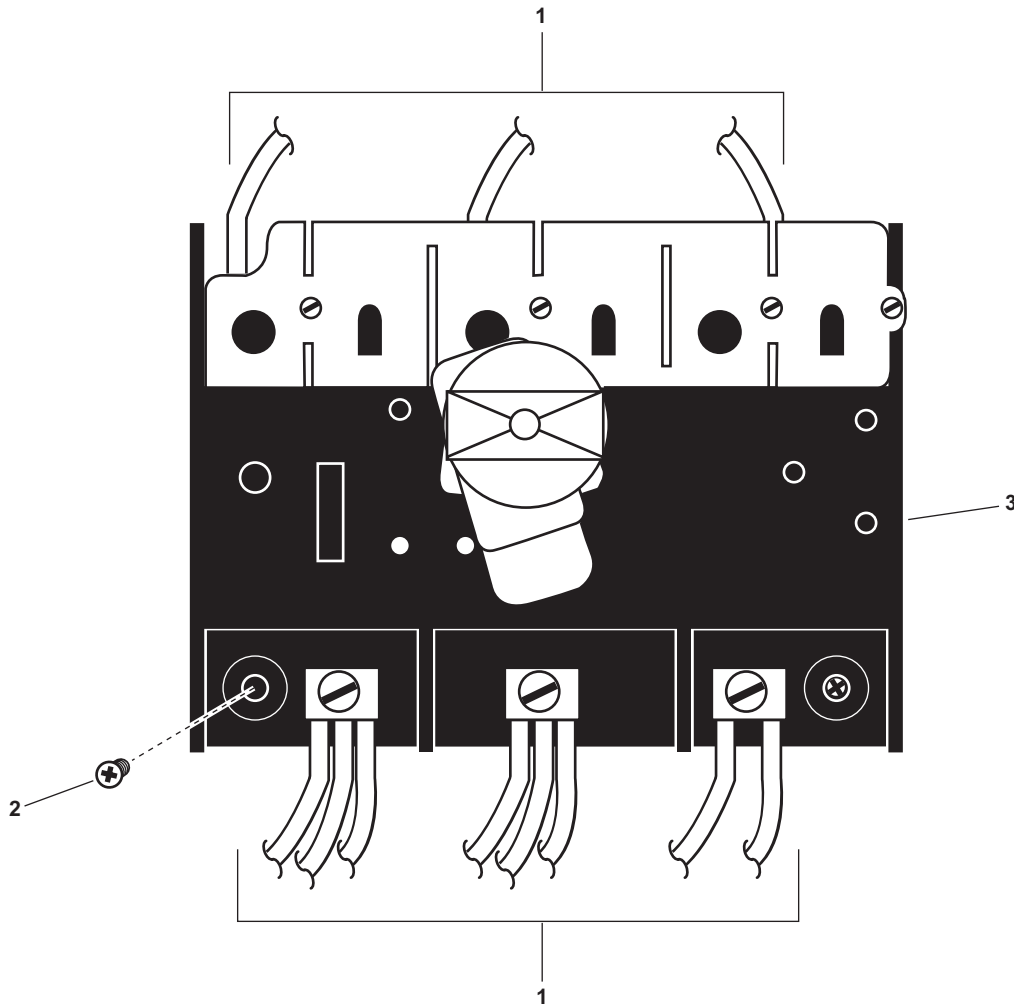

Figure 8. Interrupt Contactor Replacement

INSTALLATION

1. Position the interrupt contactor (figure 8, item 3) in the enclosure and secure it with the four mounting screws (figure 8, item 2).
2. Connect the wiring (figure 8, item 1) using the labels from step 2 of Removal as a guide. Remove the labels.
3. Perform the Follow-On Service procedure at the end of this work package.

FOLLOW-ON SERVICE

1. Position the handle (figure 1, item 3) to the RESET position, and CLOSE the controller door (figure 1, item 2). When the controller door is fully closed, release the handle.
2. Secure the controller door (figure 1, item 2) with the nine captive retaining screws (figure 1, item 1).
3. Remove the lockouts and tagouts (FM 55-502).
4. Return the MSD to operation under usual conditions (WP 0005 00) and check for normal operation of the discharge pump and blower.
5. Return the equipment to the desired readiness condition.

END OF WORK PACKAGE

**DIRECT SUPPORT MAINTENANCE
MARINE SANITATION DEVICE FOR
INLAND AND COASTAL LARGE TUG (LT)
BLOWER ASSEMBLY, BLOWER; REPAIR**

INITIAL SETUP:**Tools and Special Tools:**

Tool Kit, General Mechanic's (Item 1, Table 2, WP 0035 00)
 Puller, Mechanical (Item 3, Table 2, WP 0035 00)
 Torque Wrench (Item 8, Table 2, WP 0035 00)
 Tool Kit, Machinist's (Item 9, Table 2, WP 0035 00)
 Arbor Press (Item 10, Table 2, WP 0035 00)
 Thrust Adjuster Fork (Item 11, Table 2, WP 0035 00)
 Thrust Adjuster Saddle (Item 12, Table 2, WP 0035 00)
 Suitable Hardwood Blocks

Materials/Parts:

Dry Cleaning Solvent (Item 1, Table 1, WP 0039 00)
 Grease, General Purpose (Item 2, Table 1, WP 0039 00)
 Lubricating Oil (Item 3, Table 1, WP 0039 00)

Materials/Parts (continued):

Sealing Compound, Loctite 242 (Item 5, Table 1, WP 0039 00)
 Repair Kit, Blower (Kit, Figure 3, WP 0037 00)

Personnel Required:

One Watercraft Engineer, 88L

References:

TB 43-0218
 WP 0017 00
 WP 0021 00
 WP 0035 00
 WP 0037 00
 WP 0039 00

Equipment Conditions:

Blower assembly removed (WP 0021 00)

WARNING

Never reuse locking hardware. Reuse of locking hardware such as lockwashers, locking nuts, cotter pins, and lockwire can result in undetected loosening of fastening hardware causing catastrophic component failure resulting in death, injury, or damage to equipment. In accordance with TB 43-0218, ensure that all locking hardware is discarded upon removal and replaced with new.

DISASSEMBLY

1. Perform the Change Oil Disassembly procedure (WP 0017 00).
2. Remove the two bolts (figure 1, item 1) from the taper lock sheave (figure 1, item 2).
3. Install one of the bolts (figure 1, item 1) in the jacking hole (figure 1, item 3) of the taper lock sheave (figure 1, item 2) and tighten until the taper lock sheave is freed from the drive shaft (figure 1, item 4).
4. Remove the key (figure 1, item 5) from the drive shaft (figure 1, item 4). Remove any burrs from the key and the keyway (figure 1, item 6).
5. Remove the eight bolts (figure 1, item 7) from the gearbox cover (figure 1, item 8).
6. Remove the gearbox cover (figure 1, item 8) from the gear end head plate (figure 1, item 9).

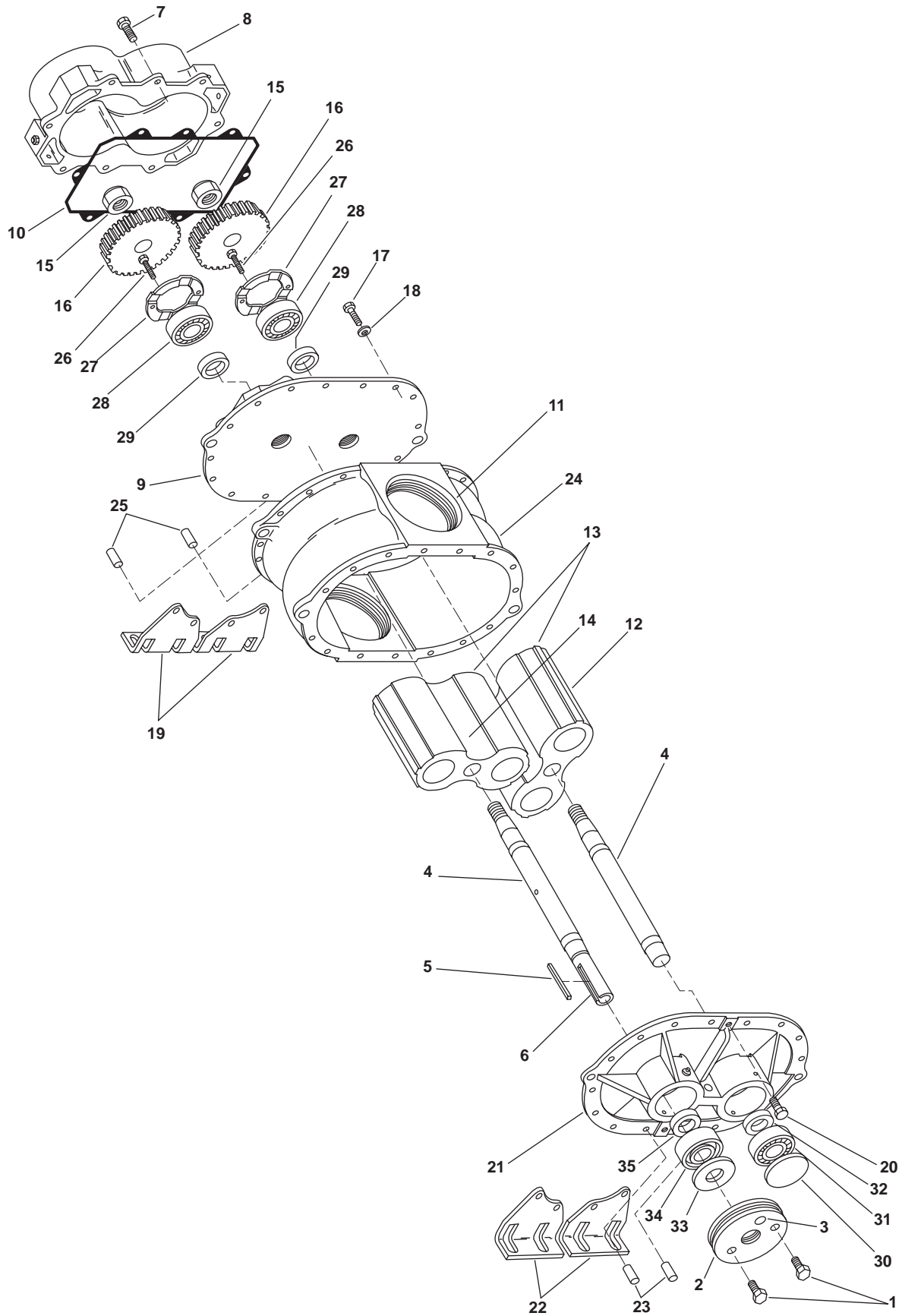

Figure 1. Blower Assembly

7. Remove the gasket (figure 1, item 10) from the gearbox cover (figure 1, item 8). Discard the gasket.
8. Through the blower pipe connection (figure 1, item 11), place an alignment mark on the strip (figure 1, item 12) of one impeller (figure 1, item 13) and on the mating waist (figure 1, item 14) of the other impeller using a piece of chalk or an indelible marker.
9. Wedge the impellers (figure 2, item 1) with blocks of hardwood (figure 2, item 2) to keep them from turning during disassembly.

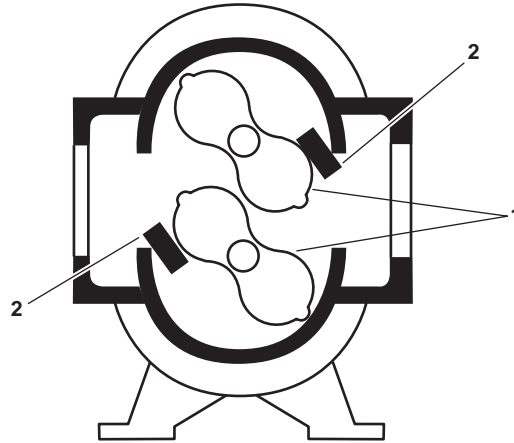

Figure 2. Impeller Removal

WARNING

Do not remove the gear nuts completely before the gears are unseated from the taper fits of the drive shafts. Failure to comply with this warning may result in severe injury or death.

10. Loosen, but do not remove, the gear nuts (figure 1, item 15) from the drive shafts (figure 1, item 4).

NOTE

As the mechanical puller setscrew is turned, the mechanical puller will have a tendency to spin, hitting the teeth of the other gear. To prevent this, hold the puller corner nut with a wrench while rotating the setscrew.

11. Using a mechanical puller, unseat the gears (figure 1, item 16) from the drive shafts (figure 1, item 4).

NOTE

Mark each gear to its drive shaft and make a note of each gear's location prior to removal from the drive shafts, so they can be returned to the same shaft during assembly.

12. Remove the gear nuts (figure 1, item 15) and the gears (figure 1, items 16) from the drive shafts (figure 1, item 4). Note the location of each gear for use during assembly.

NOTE

The two bolts that secure the gear end feet are longer than the other 12 bolts that secure the gear end head plate to the cylinder.

13. Remove the 14 bolts (figure 1, item 17) and two washers (figure 1, item 18) from the gear end head plate (figure 1, item 9). Remove the gear end feet (figure 1, item 19).
14. Remove the blocks of hardwood (figure 2, item 2) from the impellers (figure 2, item 1).

NOTE

The two bolts that secure the drive end feet to the drive end head plate and cylinder are longer than the other 12 bolts used to secure the drive end head plate to the cylinder.

15. Remove the 14 bolts (figure 1, item 20) from the drive end head plate (figure 1, item 21). Remove the drive end feet (figure 1, item 22).
16. Drive out the two dowel pins (figure 1, item 23) in the drive end head plate (figure 1, item 21).
17. Position the cylinder (figure 1, item 24) so the drive shafts (figure 1, item 4) are vertical on the gear end.
18. Using a brass hammer, tap the drive shafts (figure 1, item 4) through the gear end head plate (figure 1, item 9) and into the cylinder (figure 1, item 24).
19. Make single and double identifying punch marks on the mating edges of the gear end head plate (figure 1, item 9) and the cylinder (figure 1, item 24) to aid in proper orientation of the gear end head plate upon assembly.
20. Drive out the two dowel pins (figure 1, item 25) from the gear end head plate (figure 1, item 9).
21. Remove the four self locking cap screws (figure 1, item 26) from the two bearing clamp plates (figure 1, item 27). Remove the bearing clamp plates and discard the self locking cap screws.

NOTE

Make a note of the location of the keyed drive shaft. During assembly, the keyed drive shaft must be returned to the same location in the gear end head plate.

22. Remove the gear end head plate (figure 1, item 9) from the cylinder (figure 1, item 24).
23. Working from the inside of the gear end head plate (figure 1, item 9), tap the two bearings (figure 1, item 28) and the two bearing seals (figure 1, item 29) out of the gear end head plate. Discard the bearings and seals.
24. Make single and double identifying punch marks on the mating edges of the drive end head plate (figure 1, item 21) and the cylinder (figure 1, item 24) to aid in proper orientation of the drive end head plate upon reassembly.
25. Position the cylinder (figure 1, item 24) so the drive shafts (figure 1, item 4) are vertical on the drive end.
26. Using a brass drift, tap the drive shafts (figure 1, item 4) through the drive end head plate (figure 1, item 21) and into the cylinder (figure 1, item 24).
27. Remove the drive end head plate (figure 1, item 21) from the cylinder (figure 1, item 24).
28. Remove the impellers (figure 1, item 13) and the drive shafts (figure 1, item 4) from the cylinder (figure 1, item 24).

29. Remove the drive shafts (figure 1, item 4) from the impellers (figure 1, item 13).

NOTE

Observe the drive bearing location and the driven bearing location. These bearings cannot be used interchangeably. Make a note of their location and depth to use during assembly.

30. Working from the back of the drive end head plate (figure 1, item 21), tap the bearing cover (figure 1, item 30), the driven bearing (figure 1, item 31), and the bearing seal (figure 1, item 32) from the drive end head plate. Discard the bearing and seal.
31. Working from the back of the drive end head plate (figure 1, item 21), tap the lip drive seal (figure 1, item 33), the drive bearing (figure 1, item 34), and the bearing seal (figure 1, item 35) from the drive end head plate. Discard the bearing seal.

WARNING



Cleaning solvent is flammable and its vapor is potentially explosive. Do not use cleaning solvent in the vicinity of spark, open flame, or excessive heat. Do not use cleaning solvent in unventilated spaces. Failure to follow these precautions can result in death or serious injury.

32. Use dry cleaning solvent to clean all the removed metal parts.
33. Allow all parts to air dry prior to assembly.

ASSEMBLY

1. Apply a thin coat of sealing compound on the outer diameter of the two new bearing seals (figure 1, item 29).
2. Install the two new bearing seals (figure 1, item 29) in the gear end head plate (figure 1, item 9) with the seal lip facing towards the bearings (figure 1, item 28).
3. Position the cylinder (figure 1, item 24) on a flat surface.
4. Position the gear end head plate (figure 1, item 9) on the cylinder (figure 1, item 24) and verify that the punch marks made during Disassembly are in the proper location.
5. Install the two dowel pins (figure 1, item 25) in the gear end head plate (figure 1, item 9).

NOTE

The two bolts that secure the gear end feet to the gear end head plate and cylinder are longer than the other 12 bolts used to secure the gear end head plate to the cylinder.

6. Position the gear end feet (figure 1, item 19) on the gear end head plate (figure 1, item 9) and secure them and the gear end head plate to the cylinder (figure 1, item 24) with the 14 bolts (figure 1, item 17) and two washers (figure 1, item 18).

7. Position the cylinder (figure 1, item 24) so that it is vertical with the gear end head plate (figure 1, item 9) on the bottom. Ensure that there is enough clearance under the gear end head plate for the drive shafts (figure 1, item 4) to be installed properly.
8. Using the chalk match marks made during step 8 of Disassembly, install the impellers (figure 1, item 13) in the cylinder (figure 1, item 24).

NOTE

The keyed drive shaft must be returned to the same location it was removed from during Disassembly.

NOTE

Before starting the drive shafts through the gear end head plate's openings, make sure that the drive shaft ends have no sharp or rough edges that could damage the bearing seals.

9. Install the drive shafts (figure 1, item 4) in the impellers (figure 1, item 13) and the gear end head plate (figure 1, item 9), ensuring that the keyed drive shaft is installed in the same location it was removed from.
10. Apply a thin coat of sealing compound on the outer diameter of the two new bearing seals (figure 1, items 32 and 35).
11. Install the two new bearing seals (figure 1, items 32 and 35) in the drive end head plate (figure 1, item 21) with the seal lip facing towards the bearings (figure 1, items 31 and 34).
12. Position the drive end head plate (figure 1, item 21) on the cylinder (figure 1, item 24) and verify that the punch marks made during Disassembly are in the proper location.
13. Install the two dowel pins (figure 1, item 23) in the drive end head plate (figure 1, item 21).

NOTE

The two bolts that secure the drive end feet to the drive end head plate and cylinder are longer than the other 12 bolts used to secure the drive end head plate to the cylinder.

14. Position the drive end feet (figure 1, item 22) on the drive end head plate (figure 1, item 21) and secure them to the cylinder (figure 1, item 24) with the 14 bolts (figure 1, item 20).
15. Lubricate the two new bearings (figure 1, items 31 and 34) with a thin coat of lubricating oil.

NOTE

Cylindrical drive bearings should be installed with the inner race large shoulder facing outboard from the cylinder.

NOTE

Ensure that the drive bearing and the driven bearing are installed in the location they were removed from. These bearings cannot be used interchangeably. Use the note made during Disassembly to place these bearings in their proper location and depth.

16. Install the two new bearings (figure 1, items 31 and 34) in the drive end head plate (figure 1, item 21) using a tube with a flanged end that will contact both bearing faces simultaneously.

17. Position the cylinder (figure 1, item 24) so that it is vertical with the gear end head plate (figure 1, item 9) on the top. Ensure that there is enough clearance under the drive end head plate (figure 1, item 21) for the drive shafts (figure 1, item 4).
18. Lubricate the two new bearings (figure 1, item 28) with a thin coat of lubricating oil.

NOTE

The gear end head plate bearings are installed so that the bearings are flush with the gear end head plate shoulders.

19. Using an arbor press, install the bearings (figure 1, item 28) in the gear end head plate (figure 1, item 9).
20. Install the two bearing clamp plates (figure 1, item 27) on the gear end head plate (figure 1, item 9) and secure them with four new self locking cap screws (figure 1, item 26).
21. Position the cylinder (figure 1, item 24) on a flat surface on its gear end feet (figure 1, item 19) and drive end feet (figure 1, item 22).
22. Loosen, but do not remove, the two bolts (figure 1, items 17 and 20) that secure the gear end feet (figure 1, item 19) and the drive end feet (figure 1, item 22).
23. Level the gear end feet (figure 1, item 19) and the drive end feet (figure 1, item 22) and secure the two bolts (figure 1, items 17 and 20).
24. Wedge the impellers (figure 2, item 1) with blocks of hardwood (figure 2, item 2) to keep them from turning during assembly.

NOTE

Gears must be returned to their original drive shaft. Use the note made during Disassembly to place the gears on the proper drive shaft.

25. Install the drive gear (figure 1, item 16) and the gear nut (figure 1, item 15) on the drive shaft (figure 1, item 4) using notes from step 12 of Disassembly as a guide.
26. Torque the drive gear nut (figure 1, item 14) to 60 lb-ft (81.3 Nm).

NOTE

Gears must be returned to their original drive shaft. Use the note made during Disassembly to place the gears on the proper drive shaft.

27. Install the driven gear (figure 1, item 16) on the drive shaft (figure 1, item 4) using notes from step 12 of Disassembly as a guide.
28. Remove the hardwood (figure 2, item 2) from the impellers (figure 2, item 1).
29. Using a long set of feeler gauges, check the impeller (figure 1, item 13) fronts and backs clearances as indicated in table 1 and figure 3. The feeler gauge thickness should be a value in between the two values indicated in table 1.

Table 1. Normal Clearances for URA1 22 Blowers (Refer to Figure 3)

Frame Size	Impeller Ends			Cylinder		Impeller
	Total	Drive End Minimum	Gear End Minimum	Inlet and Discharge	Center Center	Fronts/Backs
22	.006/.010 in (.15-.25 mm)	.003 in (.08 mm)	.003 in (.08 mm)	.004/.005 in (.10-.13 mm)	.002/.003 in (.05-.08 mm)	.007/.01 in (.18-.25 mm)

30. Install the gear nut (figure 1, item 15) on the drive shaft (figure 1, item 4) and tighten slightly.
31. Check the impeller (figure 1, item 13) fronts and backs clearances at each 45 degree position as indicated in table 1 and figure 3.

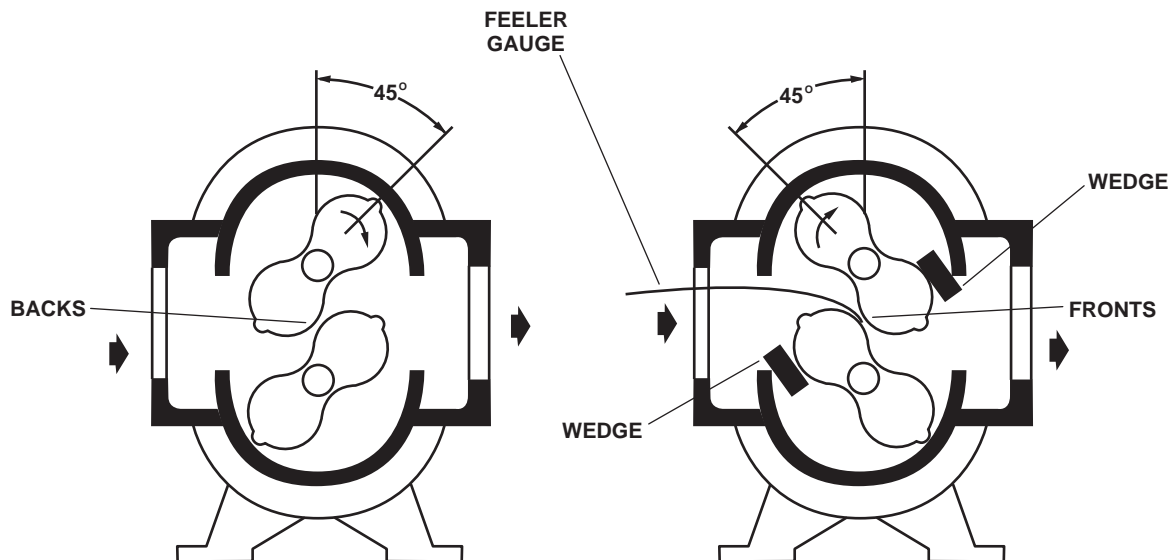

Figure 3. Impeller Fronts and Backs Clearances

32. The clearance for the impeller (figure 1, item 13) fronts and backs should be about the same and within the specified range of table 1. Adjust the gear (figure 1, item 16) as necessary to obtain the required clearances. Once the clearance is obtained, continue with the procedure. If the proper clearance cannot be obtained, a new blower is required.
33. Wedge the impellers (figure 2, item 1) with blocks of hardwood (figure 2, item 2) to keep them from turning during assembly.
34. Torque the drive gear nut (figure 1, item 15) to 60 lb-ft (81.3 Nm).
35. Remove the hardwood (figure 2, item 2) from the impellers (figure 2, item 1).

36. Rotate the drive shafts (figure 1, item 4) by hand to ensure that there are no gear (figure 1, item 16) tight spots or impeller (figure 1, item 13) contacts. If there are tight spots or impeller contact, loosen the gear nut (figure 1, item 15) and perform steps 27 through 36 until there are no tight spots or impeller contact. If there are no tight spots or impeller contact, continue with the procedure.
37. Adjust the thrust for the impeller (figure 1, item 13) by placing the flat side of the thrust adjuster saddle (figure 4, item 1) against the bearing's inner race (figure 4, item 2) and the flat side of the thrust adjuster fork (figure 4 item 3) against the back side of the gear (figure 4, item 4).

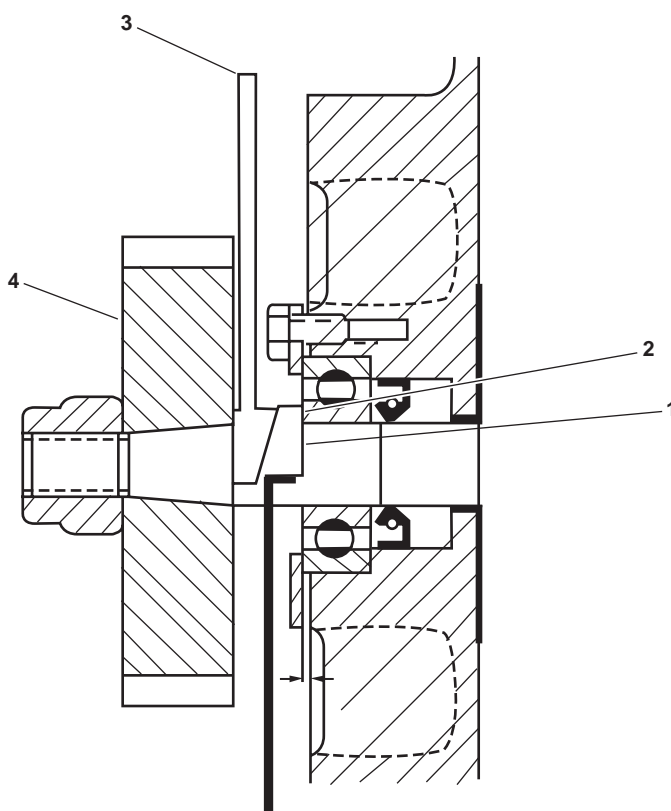

Figure 4. Impeller Thrust Adjustment

38. Install a 0.003 inch (0.8 mm) feeler gauge between the impeller (figure 1, item 13) and the gear end head plate (figure 1, item 9). Tap on the top of the thrust adjuster fork (figure 4, item 3) until the feeler gauge becomes snug.
39. Remove the feeler gauge and check end clearances. To increase the gear end clearance, tap the gear end of the drive shafts (figure 1, item 4) with a brass hammer.
40. Check the end clearances between the impellers (figure 1, item 13) and the drive end head plate (figure 1, item 21). If necessary, repeat steps 37 through 39 to adjust the drive end head plate clearance.
41. Pack the bearing cavities (figure 1, items 28, 31, and 34) with general purpose grease.
42. Install the new bearing cover (figure 1, item 30) in the drive end head plate (figure 1, item 21) using an arbor press. Drive the bearing cover into the bore until it is flush with surface of the drive end head plate.

 **CAUTION**

Exercise care not to damage the lip drive seal as it passes over the drive shaft's keyway. Failure to comply will result in damage to the equipment.

43. Carefully install the new lip drive seal (figure 1, item 33) over the drive shaft (figure 1, item 4) and into the drive end head plate (figure 1, item 21). Drive the new lip drive seal until it is flush with the drive end head plate.
44. Install a new gasket (figure 1, item 10) on the gearbox cover (figure 1, item 8) and install the gearbox cover on the gear end head plate (figure 1, item 9).
45. Install the eight bolts (figure 1, item 7) in the gearbox cover (figure 1, item 8). Tighten the eight bolts securely using a crisscross sequence pattern.
46. Carefully install the key (figure 1, item 5) into the keyway (figure 1, item 6).

NOTE

Ensure that the sheave has a slight slide fit on the shaft.

47. Install the taper lock sheave (figure 1, item 2) onto the drive shaft (figure 1, item 4) and secure it with the two bolts (figure 1, item 1).
48. Perform the Oil Change Assembly procedure (WP 0017 00).
49. Perform the Lubricate Bearings procedure (WP 0017 00).

END OF WORK PACKAGE

**DIRECT SUPPORT MAINTENANCE
MARINE SANITATION DEVICE FOR
INLAND AND COASTAL LARGE TUG (LT)
WET WELL, REPAIR**

INITIAL SETUP:**Tools and Special Tools:**

Tool Kit, General Mechanic's (Item 1, Table 2, WP 0035 00)
Multimeter (Item 4, Table 2, WP 0035 00)

Materials/Parts:

Gloves, Chemical and Oil Protective (Item 1, Table 3, WP 0038 00)
Goggles, Industrial (Item 2, Table 3, WP 0038 00)
Tag, Danger (Item 7, Table 1, WP 0039 00)
Tape, Antiseizing (Item 8, Table 1, WP 0039 00)
Switch, Float (Item 1, Figure 6, WP 0037 00)

Personnel Required:

Two Watercraft Engineers, 88L

References:

FM 55-502
WP 0005 00
WP 0035 00
WP 0037 00
WP 0038 00
WP 0039 00

Equipment Conditions:

Set to OFF the MSD DISCHARGE PUMP AND BLOWER circuit breaker (**LT 803 Only**), or the CONTROLLER FOR MSD DISCHARGE PUMP AND BLOWER circuit breaker (**All Other Vessels**) in 440V power panel No. 4. Lock out and tag out (FM 55-502).

CLOSE valves SD-1 SEWAGE INLET TO MSD and MSD-6 BLOWER DISCH TO AIR SCOURING SOV. Lock out and tag out (FM 55-502).

FLOAT SWITCH REPLACEMENT**DISASSEMBLY**

1. Remove the two screws (figure 1, item 1) securing the cover (figure 1, item 2) to the junction box (figure 1, item 3). Remove the cover.



Replace or repair components only after the affected circuit has been secured, locked out, and tagged out. Performing replacement with the circuit energized may result in injury.

2. Use a multimeter to check for available voltage at the wiring (figure 1, item 4). If voltage is present, verify that the proper circuit breaker is secured, locked out, and tagged out (FM 55-502). If no voltage is present, continue with the procedure.
3. Label, disconnect, and remove the wiring (figure 1, item 4) from the junction box (figure 1, item 3).

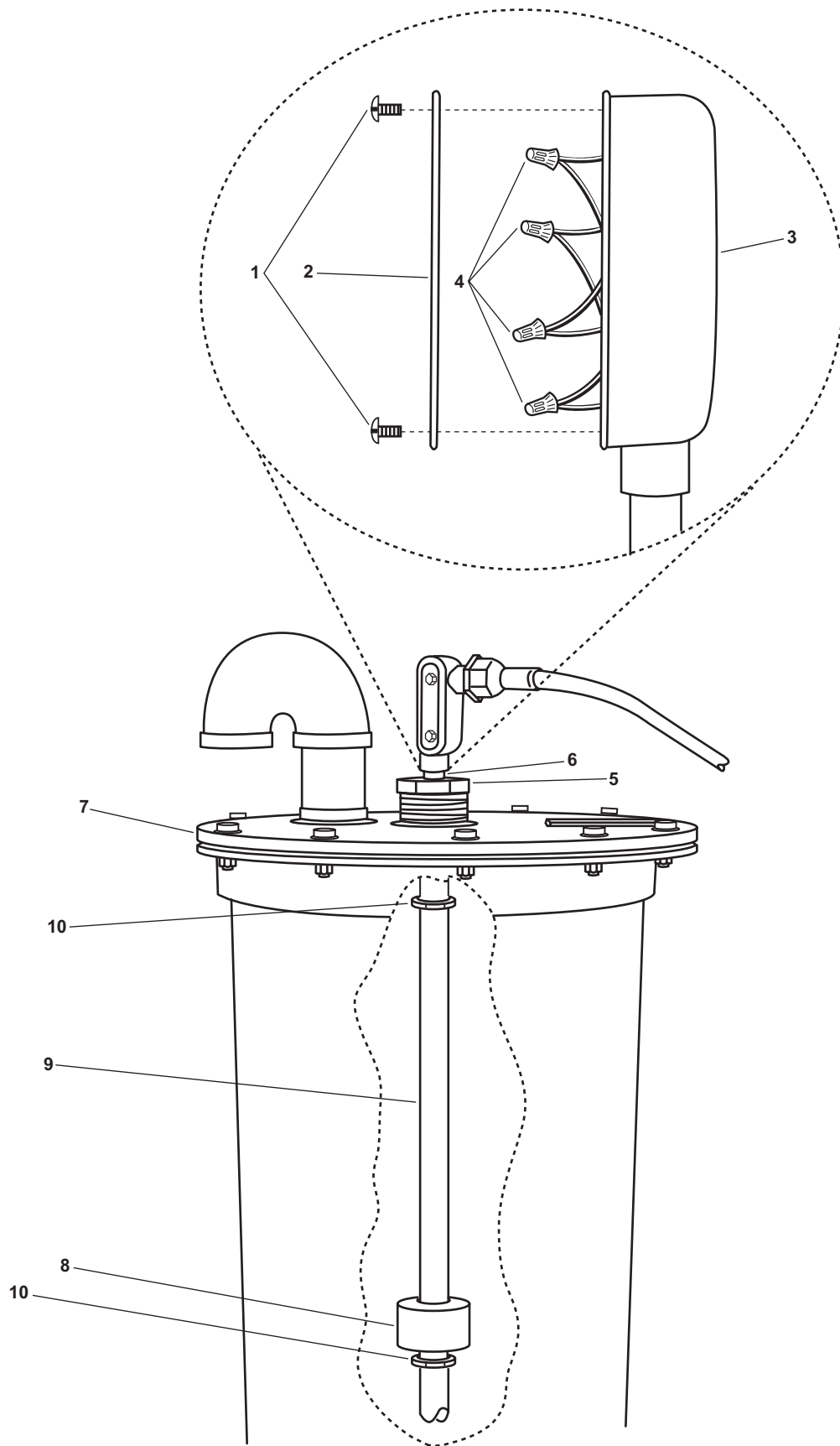

Figure 1. Float Level Switch



Sewage is a common mode of transmission for parasitic organisms that may have the capability of causing communicable diseases. After coming in contact with sewage or contaminated equipment, be sure to clean yourself with a disinfectant soap. Avoid sewage contact with skin abrasions, punctures, cuts, and other open wounds. Wipe up and clean any spills and/or contaminated equipment using a disinfectant soap.

4. Loosen the hex nut collar (figure 1, item 5), and remove the float level switch (figure 1, item 6) from the wet well tank lid (figure 1, item 7).
5. Remove the junction box (figure 1, item 3) from the float level switch (figure 1, item 6).
6. Remove the hex nut collar (figure 1, item 5) from the float level switch (figure 1, item 6).

ASSEMBLY



Removing components by means of wire brushing produces flying particles. These particles can cause serious injury to personnel. Protective goggles, gloves, and long sleeves must be worn at all times during wire brushing operations. Failure to comply with this warning can result in serious injury to personnel.

1. Clean the male threads on the hex nut collar (figure 1, item 4) with a wire brush.
2. Wrap the male threads on the hex nut collar (figure 1, item 4) with antiseizing tape and install it on the float level switch (figure 1, item 6).
3. Install the junction box (figure 1, item 3) on the float level switch (figure 1, item 6).
4. Install the float level switch (figure 1, item 6) into the wet well tank lid (figure 1, item 7) and secure it in place with the hex nut collar (figure 1, item 5).
5. Install and connect the wiring (figure 1, item 4) in the junction box (figure 1, item 3) using the labels from step 3 of Removal as a guide. Remove the labels.
6. Install the cover (figure 1, item 2) on the junction box (figure 1, item 3) and secure in place with the two screws (figure 1, item 1).

7. Remove the lockouts and tagouts (FM 55-502).
8. Return the Marine Sanitation Device to operation under usual conditions (WP 0005 00), checking for leaks and proper operation.
9. Return the equipment to the desired readiness condition.

END OF WORK PACKAGE

**DIRECT SUPPORT MAINTENANCE
MARINE SANITATION DEVICE FOR
INLAND AND COASTAL LARGE TUG (LT)
WET WELL, REPLACE**

INITIAL SETUP:**Tools and Special Tools:**

Tool Kit, General Mechanic's (Item 1, Table 2,
WP 0035 00)
Multimeter (Item 6, WP 0035 00)
Suitable Drain Pan

Materials/Parts:

Gloves, Chemical and Oil Protective (Item 1,
Table 3, WP 0038 00)
Goggles, Industrial (Item 2, Table 3,
WP 0038 00)
Tag, Danger (Item 7, Table 1, WP 0039 00)
Tape, Antiseizing (Item 8, Table 1, WP 0039 00)

Personnel Required:

Two Watercraft Engineers, 88L

References:

FM 55-502
TB 43-0218
TM 55-1925-273-10
WP 0005 00
WP 0030 00
WP 0035 00
WP 0038 00
WP 0039 00

Equipment Conditions:

Set to OFF the MSD DISCHARGE PUMP AND BLOWER circuit breaker (**LT 803 Only**), or the CONTROLLER FOR MSD DISCHARGE PUMP AND BLOWER circuit breaker (**All Other Vessels**) in 440V power panel No. 4. Lock out and tag out (FM 55-502).

All ventilation fans operating normally (TM 55-1925-273-10).

WARNING

Never reuse locking hardware. Reuse of locking hardware such as lockwashers, locking nuts, cotter pins, and lockwire can result in undetected loosening of fastening hardware causing catastrophic component failure resulting in death, injury, or damage to equipment. In accordance with TB 43-0218, ensure that all locking hardware is discarded upon removal and replaced with new.

REMOVAL

1. OPEN valve SD-3 SEWAGE DRAIN TO HOLDING TANK (figure 1, item 1).
2. CLOSE valve SD-1 SEWAGE INLET TO MSD (figure 1, item 2).
3. CLOSE valve MSD-10 WET WELL DISCHARGE (figure 1, item 3).
4. OPEN valve MSD-13 WET WELL DRAIN TO HOLDING TANK (figure 1, item 4) and drain the wet well (figure 1, item 5) into the sewage holding tank (figure 1, item 6).
5. Perform the Wet Well Repair Disassembly procedure (WP 0030 00).
6. Place a suitable drain pan under the chlorinator discharge coupling (figure 2, item 1).

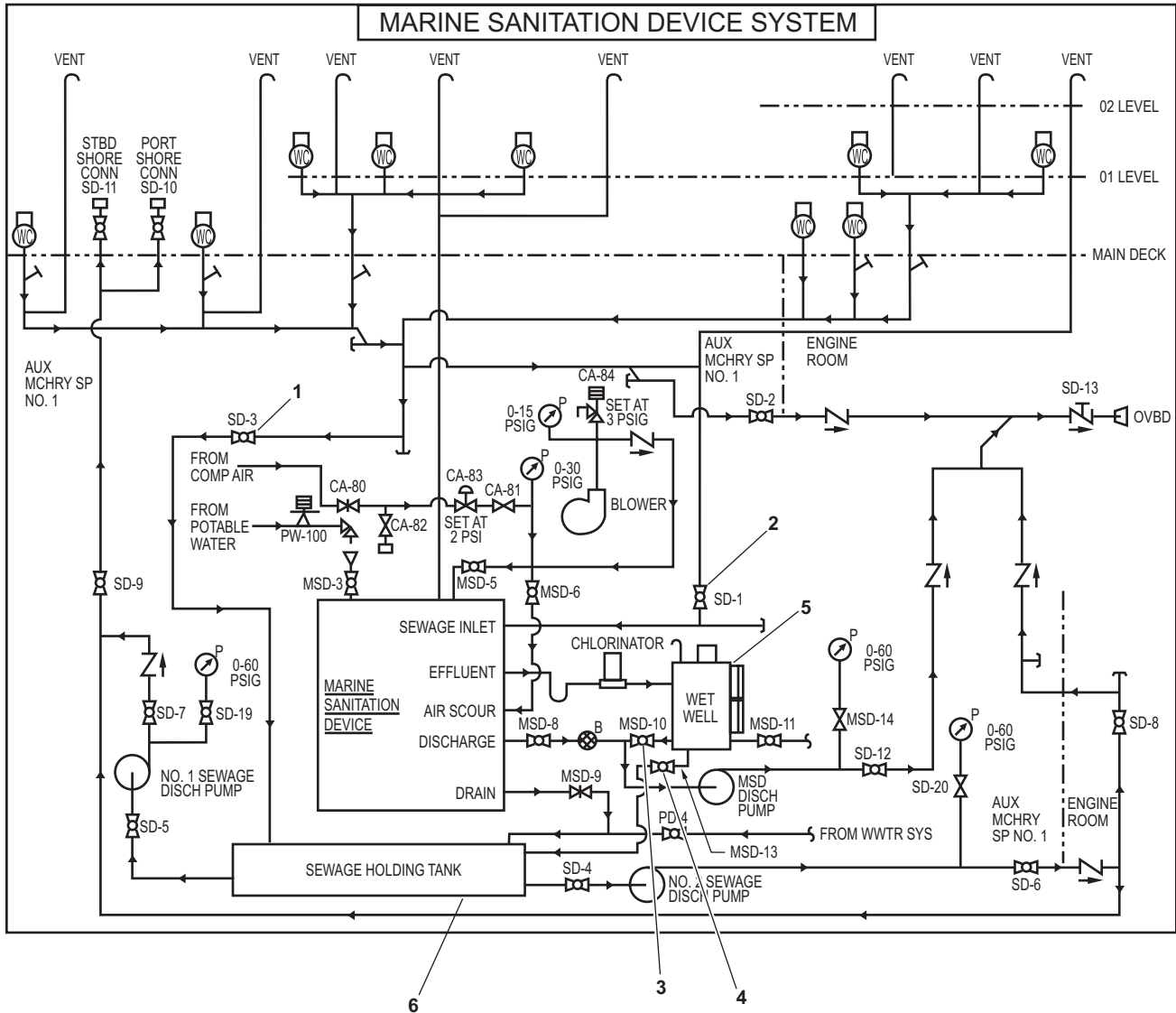
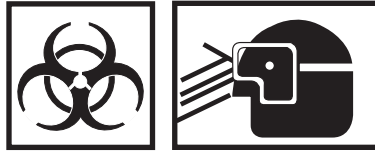

Figure 1. MSD Piping and Valve Schematic

WARNING

Sewage is a common mode of transmission for parasitic organisms that may have the capability of causing communicable diseases. After coming in contact with sewage or contaminated equipment, be sure to clean yourself with a disinfectant soap. Avoid sewage contact with skin abrasions, punctures, cuts, and other open wounds. Wipe up and clean any spills and/or contaminated equipment using a disinfectant soap.

7. Loosen the chlorinator discharge coupling (figure 2, item 1) and allow any effluent to drain into the suitable drain pan.
8. Place the suitable drain pan under the wet well inlet coupling (figure 2, item 2).
9. Loosen the wet well inlet coupling (figure 2, item 2) and allow any effluent to drain into the suitable drain pan.
10. Remove the pipe (figure 2, item 3) from the wet well inlet coupling (figure 2, item 2) and the chlorinator discharge coupling (figure 2, item 1).
11. Place the suitable drain pan under valve MSD-11 WET WELL SAMPLE (figure 2, item 4).
12. Remove the pipe plug (figure 2, item 5) from valve MSD-11 WET WELL SAMPLE (figure 2, item 4).

WARNING

Sewage is a common mode of transmission for parasitic organisms that may have the capability of causing communicable diseases. After coming in contact with sewage or contaminated equipment, be sure to clean yourself with a disinfectant soap. Avoid sewage contact with skin abrasions, punctures, cuts, and other open wounds. Wipe up and clean any spills and/or contaminated equipment using a disinfectant soap.

13. OPEN valve MSD-11 WET WELL SAMPLE (figure 2, item 4) and allow any effluent to drain into the suitable drain pan.
14. Remove valve MSD-11 WET WELL SAMPLE (figure 2, item 4) and the piping (figure 2, item 6) from the wet well (figure 2, item 7).
15. Place the suitable drain pan under the wet well discharge coupling (figure 2, item 8).
16. Verify that valve MSD-10 WET WELL DISCHARGE (figure 2, item 9) is CLOSED.

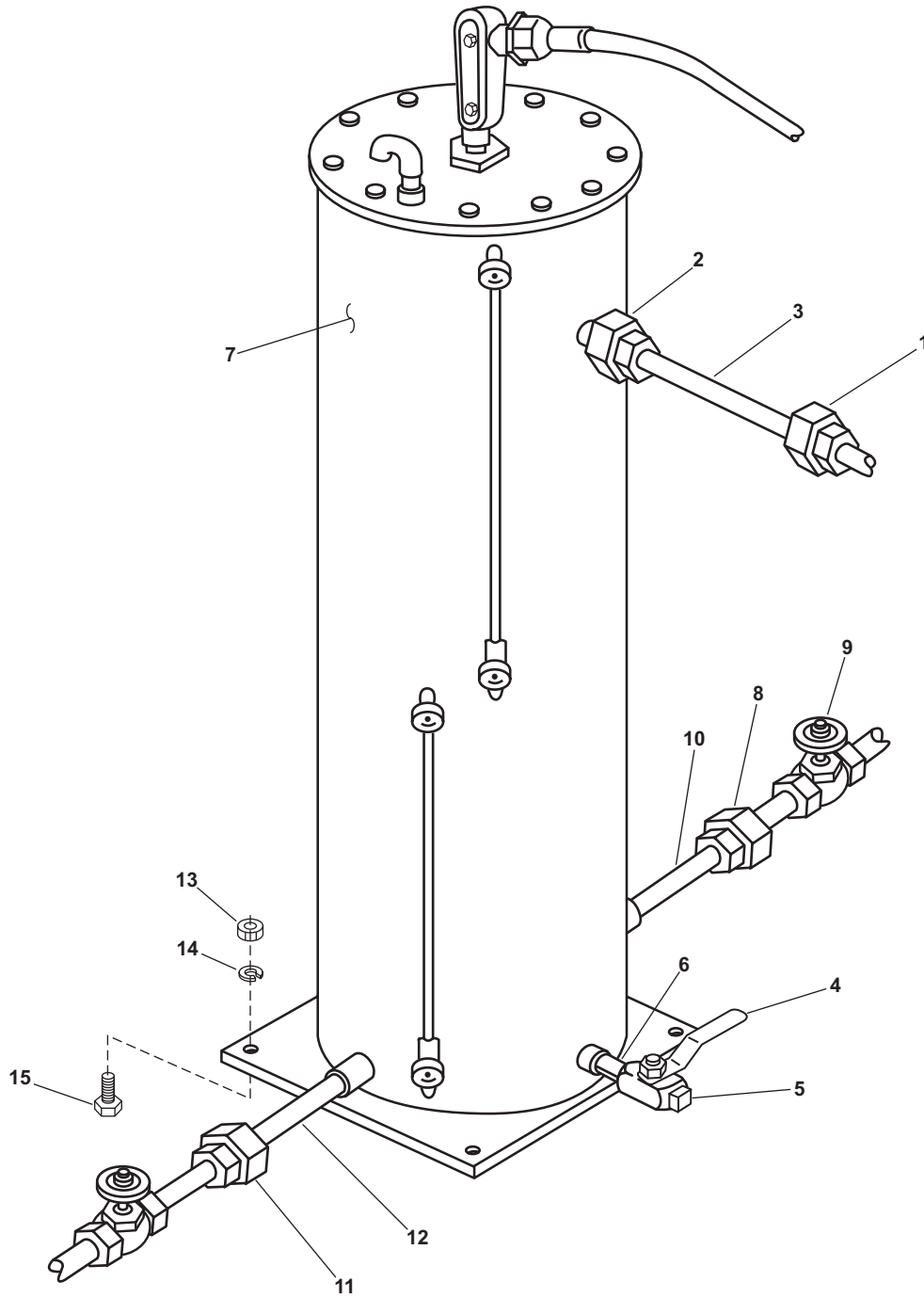
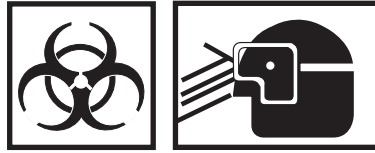

Figure 2. MSD Wet Well

WARNING

Sewage is a common mode of transmission for parasitic organisms that may have the capability of causing communicable diseases. After coming in contact with sewage or contaminated equipment, be sure to clean yourself with a disinfectant soap. Avoid sewage contact with skin abrasions, punctures, cuts, and other open wounds. Wipe up and clean any spills and/or contaminated equipment using a disinfectant soap.

17. Loosen the wet well discharge coupling (figure 2, item 8) and allow any effluent to drain into the suitable drain pan.
18. Remove the pipe (figure 2, item 10) from the wet well (figure 2, item 7) and the wet well discharge coupling (figure 2, item 8).
19. Place the suitable drain pan under the wet well drain to holding tank coupling (figure 2, item 11).

WARNING

Sewage is a common mode of transmission for parasitic organisms that may have the capability of causing communicable diseases. After coming in contact with sewage or contaminated equipment, be sure to clean yourself with a disinfectant soap. Avoid sewage contact with skin abrasions, punctures, cuts, and other open wounds. Wipe up and clean any spills and/or contaminated equipment using a disinfectant soap.

20. Loosen the wet well drain to holding tank coupling (figure 2, item 11) and allow any effluent to drain into the suitable drain pan.
21. Remove the pipe (figure 2, item 12) from wet well drain to holding tank coupling (figure 2, item 11) and the wet well (figure 2, item 7).
22. Remove the four nuts (figure 2, item 13), the four lockwashers (figure 1, item 14), and the four bolts (figure 2, item 15) from the wet well (figure 2, item 7). Discard the lockwashers.
23. Remove the wet well (figure 2, item 7) from its foundation.

INSTALLATION

1. Install the wet well (figure 2, item 7) on its foundation.
2. Install the four bolts (figure 2, item 15), the four nuts (figure 2, item 13) and the four new lockwashers (figure 2, item 14) that secure the wet well (figure 2, item 7).



Removing components by means of wire brushing produces flying particles. These particles can cause serious injury to personnel. Protective goggles, gloves, and long sleeves must be worn at all times during wire brushing operations. Failure to comply with this warning can result in serious injury to personnel.

3. Clean the male threads of the piping (figure 2, items 3, 6, 10, and 12) using a wire brush.
4. Apply antiseizing tape to the male threads of the piping (figure 2, items 3, 6, 10, and 12).
5. Install the pipe (figure 2, item 12) in the wet well drain to holding tank coupling (figure 2, item 11) and the wet well (figure 2, item 7).
6. Install the pipe (figure 2, item 10) in the wet well (figure 2, item 7) and the wet well discharge coupling (figure 2, item 8).
7. Install the pipe (figure 2, item 6) in the wet well (figure 2, item 7).
8. Install valve MSD-11 WET WELL SAMPLE (figure 2, item 4) on the pipe (figure 2, item 6).
9. Apply antiseizing tape to the male threads of the pipe plug (figure 2, item 5) and install it in valve MSD-11 WET WELL SAMPLE (figure 2, item 4).
10. Install the pipe (figure 2, item 3) in the wet well inlet coupling (figure 2, item 2) and the chlorinator discharge coupling (figure 2, item 1).
11. Perform the Wet Well Repair Assembly procedure (WP 0030 00).
12. Remove the lockouts and tagouts (FM 55-502).
13. Return all valves to the position indicated in operation under usual conditions (WP 0005 00).
14. Operate the Marine Sanitation Device (MSD) under usual conditions (WP 0005 00) and check for leaks.
15. Return the MSD to the desired readiness condition.

END OF WORK PACKAGE

Chapter 8

General Support Maintenance Instructions for Marine Sanitation Device

Inland and Coastal Large Tug (LT)

**GENERAL SUPPORT MAINTENANCE
MARINE SANITATION DEVICE FOR
INLAND AND COASTAL LARGE TUG (LT)
MARINE SANITATION DEVICE, REPAIR**

INITIAL SETUP:

Tools and Special Tools:

Tool Kit, General Mechanic's (Item 1, Table 2, WP 0035 00)
Suitable Drain Pan

References:

FM 55-502
TM 55-1925-273-10
WP 0005 00
WP 0035 00
WP 0037 00
WP 0038 00
WP 0039 00

Materials/Parts:

Gloves, Chemical and Oil Protective (Item 1, Table 3, WP 0038 00)
Goggles, Industrial (Item 2, Table 3, WP 0038 00)
Tag, Danger (Item 7, Table 1, WP 0039 00)
Tape, Antiseizing (Item 8, Table 1, WP 0039 00)
Strainer, Simplex (Item 1, Figure 1, WP 0037 00)

Equipment Conditions:

Set to OFF the MSD DISCHARGE PUMP AND BLOWER circuit breaker (**LT 803 Only**), or the CONTROLLER FOR MSD DISCHARGE PUMP AND BLOWER circuit breaker (**All Other Vessels**) in 440V power panel No. 4. Lock out and tag out (FM 55-502).

Personnel Required:

Two Watercraft Engineers, 88L

All ventilation fans operating normally (TM 55-1925-273-10).

STRAINER REPLACEMENT

DISASSEMBLY

1. OPEN valve SD-3 SEWAGE DRAIN TO HOLDING TANK (figure 1, item 1).

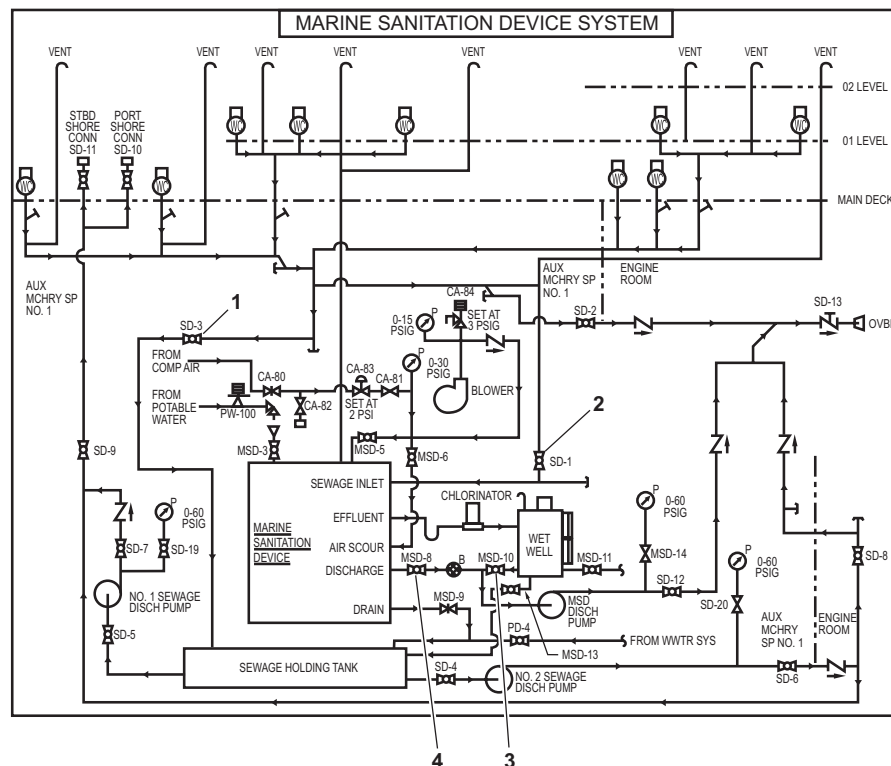

Figure 1. MSD Piping and Valve Schematic

2. CLOSE valve SD-1 SEWAGE INLET TO MSD (figure 1, item 2).
3. CLOSE valve MSD-10 WET WELL DISCHARGE (figure 1, item 3).
4. Verify that valve MSD-8 MEDIA TANK PUMP-OUT DR (figure 1, item 4) is CLOSED.
5. Place a suitable drain pan under the strainer (figure 2, item 1).

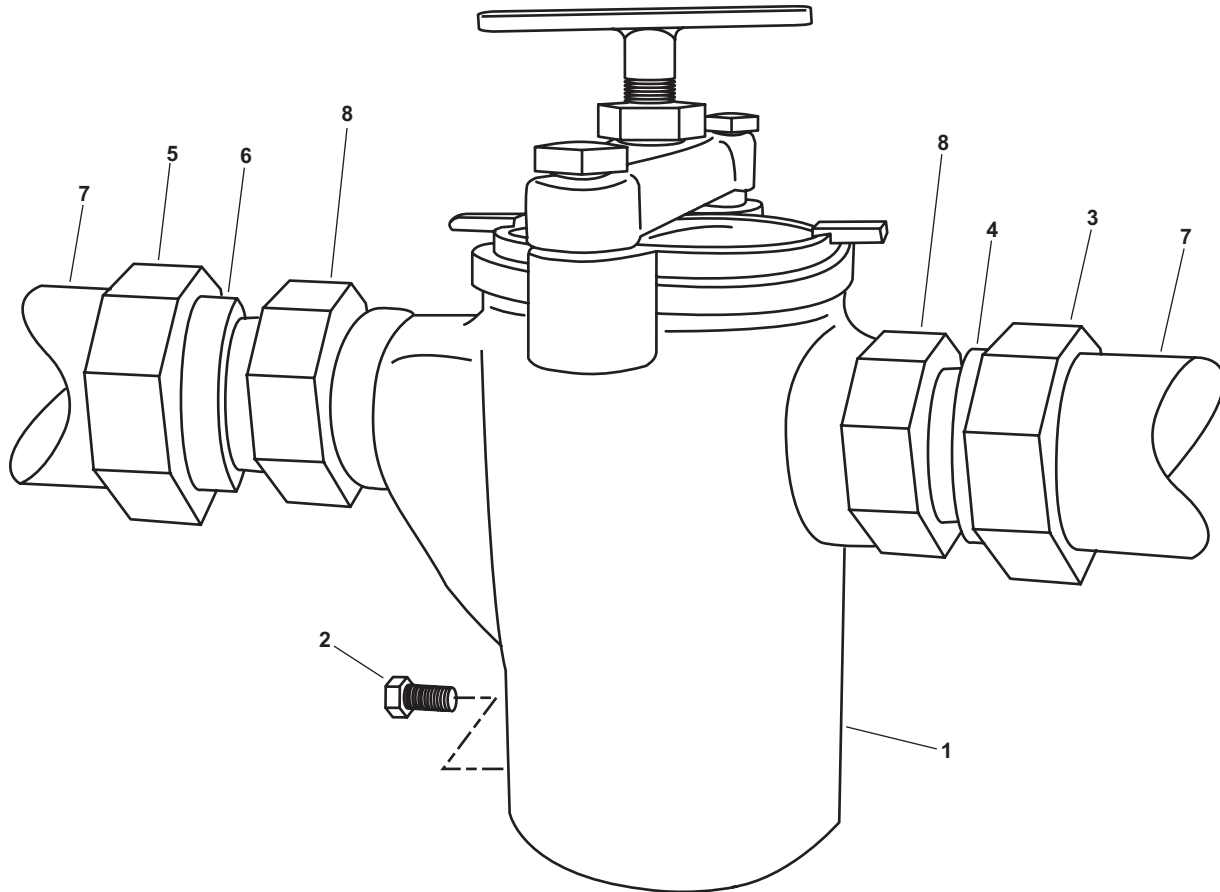
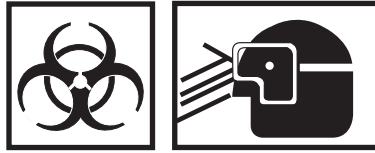

Figure 2. MSD Strainer

WARNING

Sewage is a common mode of transmission for parasitic organisms that may have the capability of causing communicable diseases. After coming in contact with sewage or contaminated equipment, be sure to clean yourself with a disinfectant soap. Avoid sewage contact with skin abrasions, punctures, cuts, and other open wounds. Wipe up and clean any spills and/or contaminated equipment using a disinfectant soap. Failure to comply can result in illness or death.

6. Loosen the drain plug (figure 2, item 2) in the strainer (figure 2, item 1) and allow any effluent to drain into the suitable drain pan.

⚠ CAUTION

Never attempt to disconnect union connections with only one wrench. Damage to the vessel's standing piping or to the valve's piping could occur. Always use two wrenches.

7. Using two wrenches, disconnect the inlet union (figure 2, item 3) from the strainer inlet fitting (figure 2, item 4) of the strainer (figure 2, item 1).
8. Using two wrenches, disconnect the outlet union (figure 2, item 5) from the strainer outlet fitting (figure 2, item 6) of the strainer (figure 2, item 1).
9. Remove the strainer (figure 2, item 1) from the piping (figure 2, item 7).
10. Remove the strainer inlet and outlet fittings (figure 2, items 4 and 6) from the strainer couplings (figure 2, item 8). Retain the strainer inlet and outlet fittings for later installation.

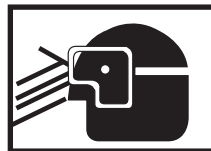
ASSEMBLY**WARNING**

Removing components by means of wire brushing produces flying particles. These particles can cause serious injury to personnel. Protective goggles, gloves, and long sleeves must be worn at all times during wire brushing operations. Failure to comply with this warning can result in serious injury or death to personnel.

1. Clean the male threads on the strainer inlet and outlet fittings (figure 2, items 4 and 6) using a wire brush.
2. Apply antiseizing tape to the male threads of the strainer inlet and outlet fittings (figure 2, items 4 and 6).

3. Install the strainer inlet and outlet fittings (figure 2, items 4 and 6) in the strainer couplings (figure 2, item 8).
4. Install the strainer (figure 2, item 1) between the piping (figure 2, item 7).

 **CAUTION**

Never attempt to connect union connections with only one wrench. Damage to the vessel's standing piping or to the valve's piping could occur. Always use two wrenches.

5. Connect the inlet union (figure 2, item 3) and outlet union (figure 2, item 5) to the strainer inlet and outlet fittings (figure 2, items 4 and 6). Tighten the inlet and outlet unions using two wrenches.
6. Verify that the drain plug (figure 2, item 2) is secured in the strainer (figure 2, item 1).
7. Remove the lockouts and tagouts (FM 55-502).
8. Perform the procedure to Operate the Marine Sanitation Device (MSD) Under Usual Conditions (WP 0005 00).
9. Check the MSD for leaks.
10. Return the equipment to the desired readiness condition.

END OF WORK PACKAGE

Chapter 9

Supporting Information for Marine Sanitation Device

Inland and Coastal Large Tug (LT)

**OPERATOR, UNIT, DIRECT SUPPORT, AND GENERAL SUPPORT MAINTENANCE
MARINE SANITATION DEVICE FOR
INLAND AND COASTAL LARGE TUG (LT)
REFERENCES**

This work package lists all field manuals, forms, technical manuals, and miscellaneous publications referenced in this manual.

ARMY REGULATIONS

AR 700-138 Army Logistics Readiness and Sustainability

FIELD MANUALS

FM 4-25.11 First Aid
FM 55-502 Watercraft Safety

TECHNICAL MANUALS

TM 38-470 Storage and Maintenance of Army Prepositioned Stock Materiel
TM 750-244-6 Procedures for Destruction of Tank-Automotive Equipment to Prevent Enemy Use
TM 55-1925-273-10 Operator's Manual for Inland and Coastal Large Tug (LT) NSN 1925-01-509-7013 (EIC XAG)

TECHNICAL BULLETINS

TB 43-0218 Inspection, Use and Tightening of Metal Fasteners Used on Tank-Automotive Equipment
TB 740-97-4 Preservation of Vessels for Storage

FORMS AND PAMPHLETS

DA Form 2028 Recommended Changes to Equipment Technical Publications
DA Form 2404 Equipment Inspection and Maintenance Worksheet
DA Form 2407 Maintenance Request
DA Form 2408-9 Equipment Control Record
DA Form 4640 Harbor Boat Deck Department Log for Class A&B Vessels
DA Form 4993 Harbor Boat Engine Department Log for Class A and C-1 Vessels
DA PAM 738-750 Functional Users Manual for The Army Maintenance Management System (TAMMS)
SF 368 Product Quality Deficiency Report

HANDBOOKS AND STANDARDS

MIL-HDBK-113 Guide for the Selection of Lubricants, Functional Fluids, Preservatives, and Specialty Products for Use in Ground Equipment Systems
MIL-HDBK-275 Guide for the Selection of Lubricant Fluids and Compounds for Use in Flight Vehicles and Components

END OF WORK PACKAGE

**OPERATOR, UNIT, DIRECT SUPPORT, AND GENERAL SUPPORT MAINTENANCE
MARINE SANITATION DEVICE FOR
INLAND AND COASTAL LARGE TUG (LT)
MAINTENANCE ALLOCATION CHART (MAC)
INTRODUCTION**

THE ARMY MAINTENANCE SYSTEM MAC

This introduction provides a general explanation of all maintenance and repair functions authorized at various maintenance levels under the standard Army Maintenance System concept.

The MAC (immediately following the introduction) designates overall authority and responsibility for the performance of maintenance functions on the identified end item or component. The application of the maintenance functions to the end item or component shall be consistent with the capacities and capabilities of the designated maintenance levels, which are shown on the MAC in column (4) as:

Unit — includes two subcolumns, C (operator/crew) and O (unit) maintenance.

Direct Support — includes an F subcolumn.

General Support — includes an H subcolumn.

Depot — includes a D subcolumn.

The tools and test equipment requirements (immediately following the MAC) list the tools and test equipment (both special tools and common tool sets) required for each maintenance function as referenced from the MAC.

The remarks (immediately following the tools and test equipment requirements) contain supplemental instructions and explanatory notes for a particular maintenance function.

MAINTENANCE FUNCTIONS

Maintenance functions are limited to and defined as follows:

1. **Inspect.** To determine the serviceability of an item by comparing its physical, mechanical, and/or electrical characteristics with established standards through examination (e.g., by sight, sound, or feel). This includes scheduled inspection and gagings and evaluation of cannon tubes.
2. **Test.** To verify serviceability by measuring the mechanical, pneumatic, hydraulic, or electrical characteristics of an item and comparing those characteristics with prescribed standards on a scheduled basis, i.e., load testing of lift devices and hydrostatic testing of pressure hoses.
3. **Service.** Operations required periodically to keep an item in proper operating condition; e.g., to clean (includes decontaminate, when required), to preserve, to drain, to paint, or to replenish fuel, lubricants, chemical fluids, or gases. This includes scheduled exercising and purging of recoil mechanisms.
4. **Adjust.** To maintain or regulate, within prescribed limits, by bringing into proper position, or by setting the operating characteristics to specified parameters.
5. **Align.** To adjust specified variable elements of an item to bring about optimum or desired performance.
6. **Calibrate.** To determine and cause corrections to be made or to be adjusted on instruments of test, measuring, and diagnostic equipment used in precision measurement. Consists of comparisons of two instruments, one of which is a certified standard of known accuracy, to detect and adjust any discrepancy in the accuracy of the instrument being compared.

7. Remove/Install. To remove and install the same item when required to perform service or other maintenance functions. Install may be the act of emplacing, seating, or fixing into position a spare, repair part, or module (component or assembly) in a manner to allow the proper functioning of an equipment or system.
8. Replace. To remove an unserviceable item and install a serviceable counterpart in its place. "Replace" is authorized by the MAC and assigned maintenance level is shown as the third position code of the Source, Maintenance and Recoverability (SMR) code.
9. Repair. The application of maintenance services, including fault location/troubleshooting, removal/installation, disassembly/assembly procedures, and maintenance actions to identify troubles and restore serviceability to an item by correcting specific damage, fault, malfunction, or failure in a part, subassembly, module (component or assembly), end item, or system.

NOTE

The following definitions are applicable to the "repair" maintenance function:

Services. Inspect, test, service, adjust, align, calibrate, and/or replace.

Fault location/troubleshooting. The process of investigating and detecting the cause of equipment malfunctioning; the act of isolating a fault within a system or Unit Under Test (UUT).

Disassembly/assembly. The step-by-step breakdown (taking apart) of a spare/functional group coded item to the level of its least component, that is assigned an SMR code for the level of maintenance under consideration (i.e., identified as maintenance significant).

Actions. Welding, grinding, riveting, straightening, facing, machining, and/or resurfacing.

10. Overhaul. That maintenance effort (service/action) prescribed to restore an item to a completely serviceable/operational condition as required by maintenance standards in appropriate technical publications. Overhaul is normally the highest degree of maintenance performed by the Army. Overhaul does not normally return an item to like new condition.
11. Rebuild. Consists of those services/actions necessary for the restoration of unserviceable equipment to a like new condition in accordance with original manufacturing standards. Rebuild is the highest degree of materiel maintenance applied to Army equipment. The rebuild operation includes the act of returning to zero those age measurements (e.g., hours/miles) considered in classifying Army equipment/components.

EXPLANATION OF COLUMNS IN THE MAC

Column (1) Group Number. Column (1) lists FGC numbers, the purpose of which is to identify maintenance significant components, assemblies, subassemblies, and modules with the Next Higher Assembly (NHA).

Column (2) Component/Assembly. Column (2) contains the item names of components, assemblies, subassemblies, and modules for which maintenance is authorized.

Column (3) Maintenance Function. Column (3) lists the functions to be performed on the item listed in column (2). (For a detailed explanation of these functions refer to "Maintenance Functions" outlined above.)

Column (4) Maintenance Level. Column (4) specifies each level of maintenance authorized to perform each function listed in column (3), by indicating work time required (expressed as manhours in whole hours or decimals) in the appropriate subcolumn. This work time figure represents the active time required to perform that maintenance function at the indicated level of maintenance. If the number or complexity of the tasks within the listed maintenance function varies at different maintenance levels, appropriate work time figures are to be shown

for each level. The work time figure represents the average time required to restore an item (assembly, subassembly, component, module, end item, or system) to a serviceable condition under typical field operating conditions. This time includes preparation time (including any necessary disassembly/assembly time), troubleshooting/fault location time, and quality assurance time in addition to the time required to perform the specific tasks identified for the maintenance functions authorized in the MAC. The symbol designations for the various maintenance levels are as follows:

- C Operator or crew maintenance
- O Unit maintenance
- F Direct support maintenance
- L Specialized repair activity (SRA)
- H General support maintenance
- D Depot maintenance

NOTE

The "L" maintenance level is not included in column (4) of the MAC. Functions to this level of maintenance are identified by a work time figure in the "H" column of column (4), and an associated reference code is used in the REMARKS column (6). This code is keyed to the remarks and the SRA complete repair application is explained there.

Column (5) Tools and Equipment Reference Code. Column (5) specifies, by code, those common tool sets (not individual tools), common Test, Measurement and Diagnostic Equipment (TMDE), and special tools, special TMDE and special support equipment required to perform the designated function. Codes are keyed to the entries in the tools and test equipment table.

Column (6) Remarks Code. When applicable, this column contains a letter code, in alphabetical order, which is keyed to the remarks table entries.

EXPLANATION OF COLUMNS IN THE TOOLS AND TEST EQUIPMENT REQUIREMENTS

Column (1) Tool or Test Equipment Reference Code. The tool or test equipment reference code correlates with a code used in column (5) of the MAC.

Column (2) Maintenance Level. The lowest level of maintenance authorized to use the tool or test equipment.

Column (3) Nomenclature. Name or identification of the tool or test equipment.

Column (4) National Stock Number (NSN). The NSN of the tool or test equipment.

Column (5) Tool Number. The manufacturer's part number, model number, or type number.

EXPLANATION OF COLUMNS IN THE REMARKS

Column (1) Remarks Code. The code recorded in column (6) of the MAC.

Column (2) Remarks. This column lists information pertinent to the maintenance function being performed as indicated in the MAC.

END OF WORK PACKAGE

**OPERATOR, UNIT, DIRECT SUPPORT, AND GENERAL SUPPORT MAINTENANCE
MARINE SANITATION DEVICE FOR
INLAND AND COASTAL LARGE TUG (LT)
MAINTENANCE ALLOCATION CHART**

Table 1. MAC for Marine Sanitation Device for Inland and Coastal Large Tug

(1) GROUP NUMBER	(2) COMPONENT/ ASSEMBLY	(3) MAINTENANCE FUNCTION	(4) MAINTENANCE LEVEL					(5) TOOLS AND EQUIP	(6) REMARKS
			FIELD			SUSTAINMENT			
			UNIT		DIRECT SUPPORT	GENERAL SUPPORT	DEPOT		
			C	O	F	H	D		
050304	Marine Sanitation Device	Inspect	0.5						A
		Adjust	0.5					1,6	
		Service	0.5					1,6	
		Replace		1.5	3.0	6.0	--	1,2	
		Repair					1,7		
05030401	Controller	Inspect	0.5						
		Repair	1.0		3.0			2	
05030402	Blower Assembly	Inspect	0.3						
		Adjust	0.5					1	
		Service	0.5					1,5	
		Repair	3.0					1	
0503040201	Blower	Inspect	0.3						B
		Service	0.5					1	
		Replace		1.5				1	
		Repair		3.0	6.0			1,3,8,9, 10,11,12	
0503040202	Motor	Inspect	0.3						
		Service	0.5					1	
		Replace		1.5				1,4	
05030403	Chlorinator	Inspect	0.3						
		Service	0.5					1	
		Replace		1.5				1	
05030404	Pump Assembly	Inspect	0.3						
		Service	0.5					1	
		Replace		1.5				1,2	
		Repair		3.0				1	
0503040401	Pump	Inspect	0.3						
		Service	0.5					1	
		Replace		1.5				1,2	

Table 1. MAC for Marine Sanitation Device for Inland and Coastal Large Tug (continued)

(1) GROUP NUMBER	(2) COMPONENT/ ASSEMBLY	(3) MAINTENANCE FUNCTION	(4) MAINTENANCE LEVEL					(5) TOOLS AND EQUIP	(6) REMARKS
			FIELD		SUSTAINMENT				
			UNIT		DIRECT SUPPORT	GENERAL SUPPORT	DEPOT		
			C	O	F	H	D		
0503040402	Motor	Inspect	0.3						
		Service	0.5						1
		Replace		1.5					1,2
05030405	Wet Well	Inspect	1.0						
		Repair	2.0		3.0				1,4
		Replace			8.0				1

Table 2. Tools and Test Equipment for Marine Sanitation Device for Inland and Coastal Large Tug

TOOL OR TEST EQUIPMENT REF CODE	MAINTENANCE LEVEL	NOMENCLATURE	NATIONAL STOCK NUMBER	TOOL NUMBER
1	C	Tool Kit, General Mechanic's	5180-00-629-9783	SC5180-90-CL-N55 (50980)
2	O	Tool Kit, Electrician's	5180-00-313-3045	SC5180-90-CL-N35 (50980)
3	F	Puller, Mechanical	5120-01-349-2706	812-977-001 (51729)
4	O	Multimeter	6625-01-265-6000	27 W/ACCE (89536)
5	C	Lubricating Gun, Hand	4930-00-223-3389	7584 (57733)
6	C	Test Kit, Sanitizer		ICQ-260 (93255)
7	F	Wrench, Pipe, Adj, Heavy Duty Aluminum Handle, 18 Long 1 to 2 Cap, Type 2, Class C	5120-00-277-1479	5120-00-277-1479 (80244)
8	F	Wrench, Torque, 0-250 FT-LB	5120-00-640-6365	B107.14M (05047)
9	F	Tool Kit, Machinist's	5280-00-511-1950	SC5280-95CLA02 (19204)
10	F	Press, Arbor	3444-00-223-8359	02001 (15746)
11	F	Fork, Thrust Adjuster		812-973-00X (3E174)
12	F	Saddle, Thrust Adjuster		812-974-00X (3E174)

Table 3. Remarks for Marine Sanitation Device for Inland and Coastal Large Tug

REFERENCE CODE	REMARKS
A	Air scour and drain media tank at 3 month intervals
B	Lubricate at weekly intervals and change oil quarterly

END OF WORK PACKAGE

**OPERATOR, UNIT, DIRECT SUPPORT, AND GENERAL SUPPORT MAINTENANCE
MARINE SANITATION DEVICE FOR
INLAND AND COASTAL LARGE TUG (LT)
REPAIR PARTS AND SPECIAL TOOLS LIST
INTRODUCTION**

SCOPE

This RPSTL lists and authorizes spares and repair parts; special tools; special test, measurement, and diagnostic equipment (TMDE); and other special support equipment required for performance of operator, unit, direct support, and general support maintenance of the Marine Sanitation Device (MSD) for Inland and Coastal Large Tug (LT). It authorizes the requisitioning, issue, and disposition of spares, repair parts, and special tools as indicated by the source, maintenance, and recoverability (SMR) codes.

GENERAL

In addition to the Introduction work package, this RPSTL is divided into the following work packages.

1. **Repair Parts List Work Packages.** Work packages containing lists of spares and repair parts authorized by this RPSTL for use in the performance of maintenance. These work packages also include parts which must be removed for replacement of the authorized parts. Parts lists are composed of functional groups in ascending alphanumeric sequence, with the parts in each group listed in ascending figure and item number sequence. Sending units, brackets, filters, and bolts are listed with the component they mount on. Bulk materials are listed by item name in FIG. BULK at the end of the work packages. Repair parts kits are listed separately in their own functional group and work package. Repair parts for reparable special tools are also listed in a separate work package. Items listed are shown on the associated illustrations.
2. **Special Tools List Work Packages.** Work packages containing lists of special tools, special TMDE, and special support equipment authorized by this RPSTL (as indicated by Basis of Issue (BOI) information in the DESCRIPTION AND USABLE ON CODE (UOC) column). Tools that are components of common tool sets and/or Class VII are not listed.
3. **Cross-Reference Indexes Work Packages.** There are two crossreference indexes work packages in this RPSTL: the National Stock Number (NSN) Index work package and the Part Number (P/N) Index work package. The National Stock Number Index work package refers you to the figure and item number. The Part Number Index work package refers you to the figure and item number.

EXPLANATION OF COLUMNS IN THE REPAIR PARTS LIST AND SPECIAL TOOLS LIST WORK PACKAGES

ITEM NO. (Column (1)). Indicates the number used to identify items called out in the illustration.

SMR CODE (Column (2)). The SMR code containing supply/requisitioning information, maintenance level authorization criteria, and disposition instruction, as shown in the following breakout:

<u>Source Code</u>	<u>Maintenance Code</u>	<u>Recoverability Code</u>
<p><u>XX</u> 1st two positions: How to get an item.</p>	<p><u>XX</u> 3rd position: Who can install, replace, or use the item.</p>	<p><u>X</u> 5th position: Who determines disposition action on unserviceable items.</p>

*Complete Repair: Maintenance capacity, capability, and authority to perform all corrective maintenance tasks of the "Repair" function in a use/user environment in order to restore serviceability to a failed item.

Source Code. The source code tells you how you get an item needed for maintenance, repair, or overhaul of an end item/equipment. Explanations of source codes follow:

<u>Source Code</u>	<u>Application/Explanation</u>
PA PB PC PD PE PF PG	Stock items; use the applicable NSN to requisition/request items with these source codes. They are authorized to the level indicated by the code entered in the 3rd position of the SMR code.
	NOTE Items coded PC are subject to deterioration.
KD KF KB	Items with these codes are not to be requested/requisitioned individually. They are part of a kit which is authorized to the maintenance level indicated in the 3rd position of the SMR code. The complete kit must be requisitioned and applied.
MO-Made at unit/AVUM level MF-Made at DS/AVIM level MH-Made at GS level ML-Made at SRA MD-Made at depot	Items with these codes are not to be requisitioned/requested individually. They must be made from bulk material which is identified by the P/N in the DESCRIPTION AND USABLE ON CODE (UOC) column and listed in the bulk material group work package of the RPSTL. If the item is authorized to you by the 3rd position code of the SMR code, but the source code indicates it is made at higher level, order the item from the higher level of maintenance.
AO-Assembled by unit/ AVUM level AF-Assembled by DS/AVIM level AH-Assembled by GS level AL-Assembled by SRA AD-Assembled by depot	Items with these codes are not to be requested/requisitioned individually. The parts that make up the assembled item must be requisitioned or fabricated and assembled at the level of maintenance indicated by the source code. If the 3rd position of the SMR code authorizes you to replace the item, but the source code indicates the item is assembled at a higher level, order the item from the higher level of maintenance.
XA	Do not requisition an "XA" coded item. Order the next higher assembly.(Refer to NOTE below.)
XB	If an item is not available from salvage, order it using the CAGEC and P/N.
XC	Installation drawings, diagrams, instruction sheets, field service drawings; identified by manufacturer's P/N.
XD	Item is not stocked. Order an XD-coded item through normal supply channels using the CAGEC and P/N given, if no NSN is available.

NOTE

Cannibalization or controlled exchange, when authorized, may be used as a source of supply for items with the above source codes except for those items source coded "XA" or those aircraft support items restricted by requirements of AR 750-1.

Maintenance Code. Maintenance codes tell you the level(s) of maintenance authorized to use and repair support items. The maintenance codes are entered in the third and fourth positions of the SMR code as follows:

Third Position. The maintenance code entered in the third position tells you the lowest maintenance level authorized to remove, replace, and use an item. The maintenance code entered in the third position will indicate authorization to the following levels of maintenance:

<u>Maintenance Code</u>	<u>Application/Explanation</u>
C -	Crew or operator maintenance done within unit/AVUM maintenance.
O -	Unit level/AVUM maintenance can remove, replace, and use the item.
F -	Direct support/AVIM maintenance can remove, replace, and use the item.
H -	General support maintenance can remove, replace, and use the item.
L -	Specialized repair activity can remove, replace, and use the item.
D -	Depot can remove, replace, and use the item.

Fourth Position. The maintenance code entered in the fourth position tells you whether or not the item is to be repaired and identifies the lowest maintenance level with the capability to do complete repair (perform all authorized repair functions).

NOTE

Some limited repair may be done on the item at a lower level of maintenance, if authorized by the Maintenance Allocation Chart (MAC) and SMR codes.

<u>Maintenance Code</u>	<u>Application/Explanation</u>
O -	Unit/AVUM is the lowest level that can do complete repair of the item.
F -	Direct support/AVIM is the lowest level that can do complete repair of the item.
H -	General support is the lowest level that can do complete repair of the item.
L -	Specialized repair activity (enter specialized repair activity designator) is the lowest level that can do complete repair of the item.
D -	Depot is the lowest level that can do complete repair of the item.
Z -	Nonrepairable. No repair is authorized.
B -	No repair is authorized. No parts or special tools are authorized for maintenance of "B" coded item. However, the item may be reconditioned by adjusting, lubricating, etc., at the user level.

Recoverability Code. Recoverability codes are assigned to items to indicate the disposition action on unserviceable items. The recoverability code is shown in the fifth position of the SMR code as follows:

<u>Recoverability Code</u>	<u>Application/Explanation</u>
Z -	Nonrepairable item. When unserviceable, condemn and dispose of the item at the level of maintenance shown in the third position of the SMR code.
O -	Reparable item. When uneconomically repairable, condemn and dispose of the item at the unit level.

<u>Recoverability Code</u>	<u>Application/Explanation</u>
F -	Reparable item. When uneconomically reparable, condemn and dispose of the item at the direct support level.
H -	Reparable item. When uneconomically reparable, condemn and dispose of the item at the general support level.
D -	Reparable item. When beyond lower level repair capability, return to depot. Condemnation and disposal of item are not authorized below depot level.
L -	Reparable item. Condemnation and disposal not authorized below Specialized Repair Activity (SRA).
A -	Item requires special handling or condemnation procedures because of specific reasons (such as precious metal content, high dollar value, critical material, or hazardous material). Refer to appropriate manuals/directives for specific instructions.

NSN (Column (3)). The NSN for the item is listed in this column.

CAGEC (Column (4)). The Commercial and Government Entity Code (CAGEC) is a five-digit code which is used to identify the manufacturer, distributor, or Government agency/activity that supplies the item.

PART NUMBER (Column (5)). Indicates the primary number used by the manufacturer (individual, company, firm, corporation, or Government activity), which controls the design and characteristics of the item by means of its engineering drawings, specifications, standards, and inspection requirements to identify an item or range of items.

NOTE

When you use an NSN to requisition an item, the item you receive may have a different P/N from the number listed.

DESCRIPTION AND USABLE ON CODE (UOC) (Column (6)). This column includes the following information:

1. The federal item name, and when required, a minimum description to identify the item.
2. P/Ns of bulk materials are referenced in this column in the line entry to be manufactured or fabricated.
3. Hardness Critical Item (HCI). A support item that provides the equipment with special protection from electromagnetic pulse (EMP) damage during a nuclear attack.
4. The statement END OF FIGURE appears just below the last item description in column (6) for a given figure in both the repair parts list and special tools list work packages.

QTY (Column (7)). The QTY (quantity per figure) column indicates the quantity of the item used in the breakout shown on the illustration/figure, which is prepared for a functional group, subfunctional group, or an assembly. A "V" appearing in this column instead of a quantity indicates that the quantity is variable and quantity may change from application to application.

EXPLANATION OF CROSS-REFERENCE INDEXES WORK PACKAGES FORMAT AND COLUMNS

1. National Stock Number (NSN) Index Work Package.

STOCK NUMBER Column. This column lists the NSN in National item identification number (NIIN) sequence. The NIIN consists of the last nine digits of the NSN.

NSN
 (e.g., 5385-01-574-1476)
 NIIN

When using this column to locate an item, ignore the first four digits of the NSN. However, the complete NSN should be used when ordering items by stock number.

FIG. Column. This column lists the number of the figure where the item is identified/located. The figures are in numerical order in the repair parts list and special tools list work packages.

ITEM Column. The item number identifies the item associated with the figure listed in the adjacent FIG. column. This item is also identified by the NSN listed on the same line.

2. **Part Number (P/N) Index Work Package.** P/Ns in this index are listed in ascending alphanumeric sequence (vertical arrangement of letter and number combinations which places the first letter or digit of each group in order A through Z, followed by the numbers 0 through 9 and each following letter or digit in like order).

PART NUMBER Column. Indicates the P/N assigned to the item.

FIG. Column. This column lists the number of the figure where the item is identified/located in the repair parts list and special tools list work packages.

ITEM Column. The item number is the number assigned to the item as it appears in the figure referenced in the adjacent figure number column.

Fabrication Instructions. Bulk materials required to manufacture items are listed in the bulk material functional group of this RPSTL. Part numbers for bulk material are also referenced in the Description Column of the line item entry for the item to be manufactured/fabricated. Detailed fabrication instructions for items source coded to be manufactured or fabricated are found in the applicable procedure.

Index Numbers. Items which have the word BULK in the figure column will have an index number shown in the item number column. This index number is a cross-reference between the NSN / P/N index work packages and the bulk material list in the repair parts list work package.

HOW TO LOCATE REPAIR PARTS

1. **When NSNs or P/Ns Are Not Known.**

First. Using the table of contents, determine the assembly group to which the item belongs. This is necessary since figures are prepared for assembly groups and subassembly groups, and lists are divided into the same groups.

Second. Find the figure covering the functional group or the subfunctional group to which the item belongs.

Third. Identify the item on the figure and note the number(s).

Fourth. Look in the repair parts list work packages for the figure and item numbers. The NSNs and part numbers are on the same line as the associated item numbers.

2. **When NSN Is Known.**

First. If you have the NSN, look in the STOCK NUMBER column of the NSN index work package. The NSN is arranged in NIIN sequence. Note the figure and item number next to the NSN.

Second. Turn to the figure and locate the item number. Verify that the item is the one you are looking for.

3. **When P/N Is Known.**

First. If you have the P/N and not the NSN, look in the PART NUMBER column of the P/N index work package. Identify the figure and item number.

Second. Look up the item on the figure in the applicable repair parts list work package.

END OF WORK PACKAGE

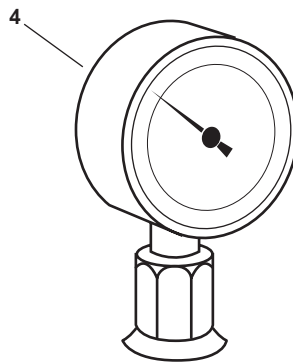
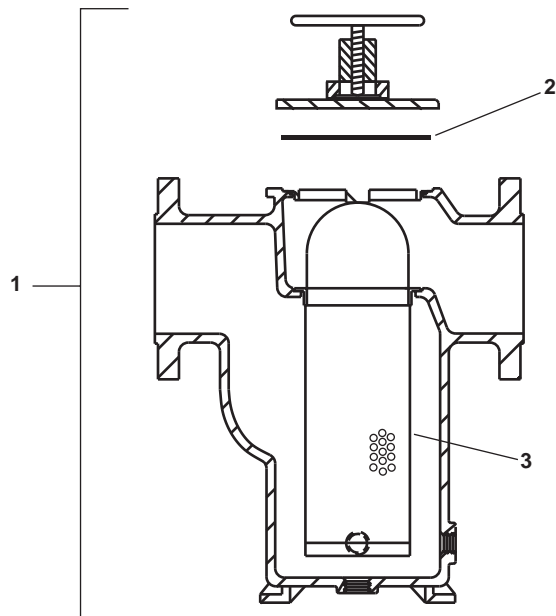

Figure 1. Marine Sanitation Device (Sheet 1 of 2)

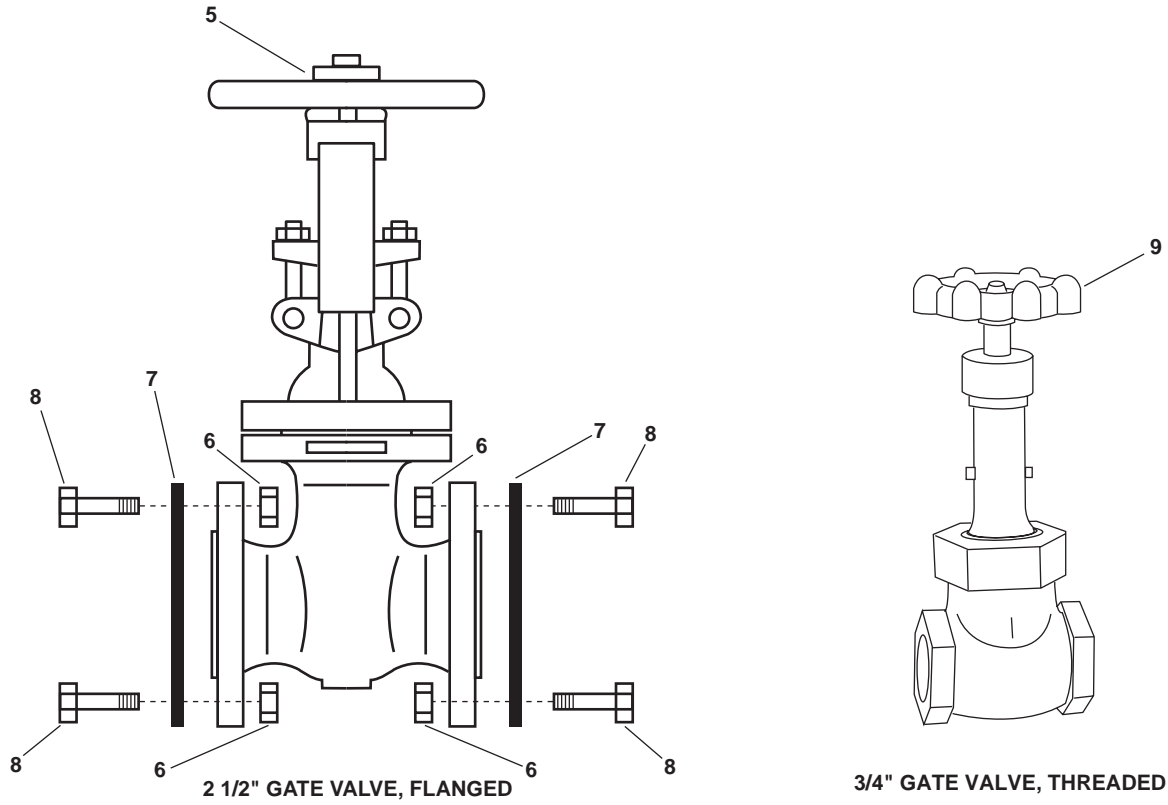

Figure 1. Marine Sanitation Device (Sheet 2 of 2)

(1)	(2)	(3)	(4)	(5)	(6)	(7)
ITEM NO.	SMR CODE	NSN	CAGEC	PART NUMBER	DESCRIPTION AND USABLE ON CODE (UOC)	QTY
					GROUP 050304	
					FIG. 1 MARINE SANITATION DEVICE	
1	XDOOO		73124	ST0720200T1C	STRAINER,SIMPLEX,2"	1
2	PAOZZ	5331-01-138-7111	73124	ST264-Z-5-B	.O-RING	1
3	XDOZZ	4730-01-325-4141	73124	ST264STXX	.STRAINER ELEMENT,SE	1
4	PAOZZ	6685-00-057-1404	61349	1469951	GAGE,PRESSURE	1
5	XDOZZ		OWLX8	052102.450	VALVE,GATE,2-1/2"	1
6	PAOZZ		39428	90810A035	NUT,HEXAGON	8
7	PAOZZ	5330-01-529-2546	0B6K6	761125-025	GASKET	2
8	PAOZZ		39428	90780A813	SCREW,CAP,HEXAGON H	8
9	XDOZZ		OWLX8	052202.150	VALVE,GATE,3/4"	1
					End of Figure	

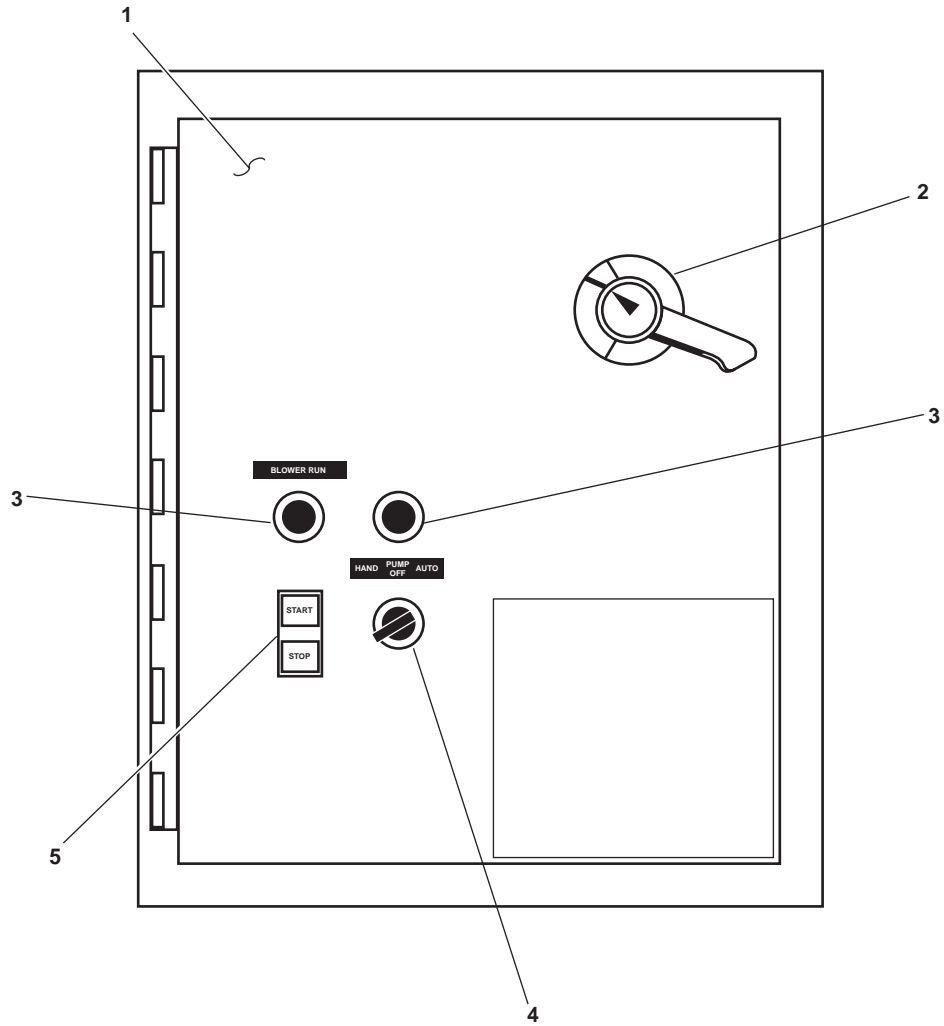

Figure 2. Controller (Sheet 1 of 2)

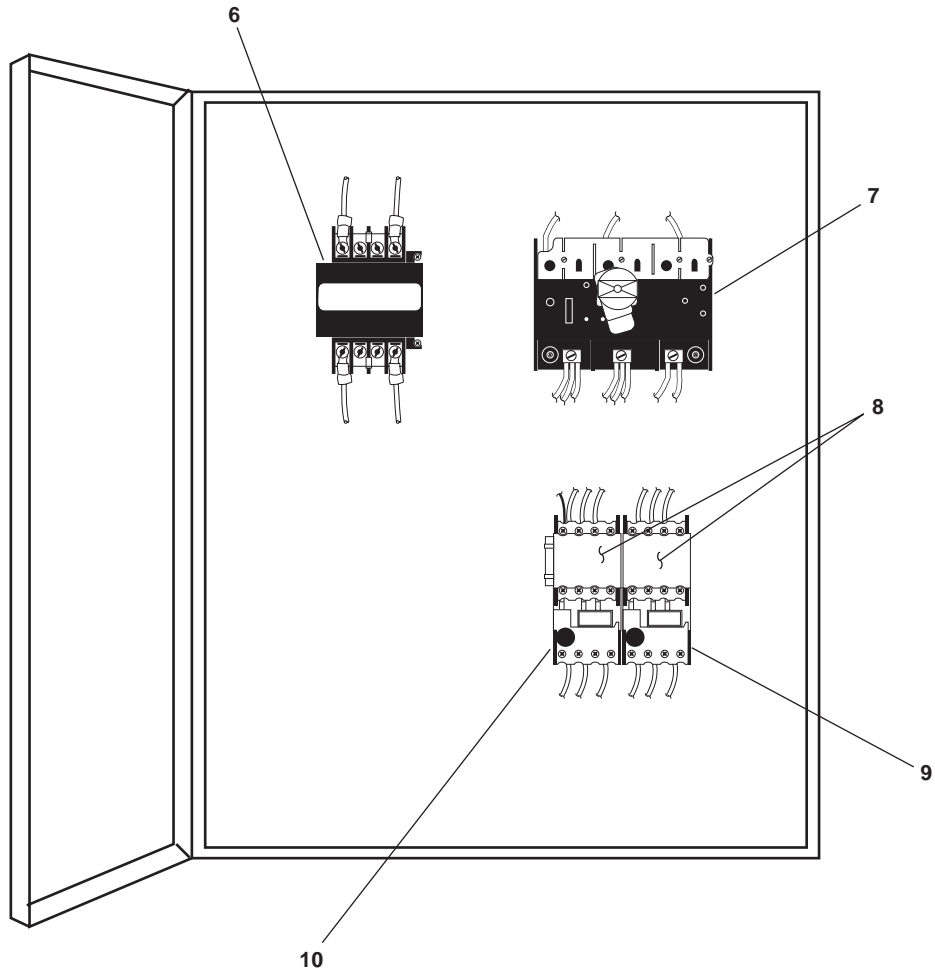

Figure 2. Controller (Sheet 2 of 2)

(1)	(2)	(3)	(4)	(5)	(6)	(7)
ITEM NO.	SMR CODE	NSN	CAGEC	PART NUMBER	DESCRIPTION AND USABLE ON CODE (UOC)	QTY
					GROUP 05030401	
					FIG. 2 CONTROLLER	
1	XCOFF		57715	3WD-78-734-732A	PANEL,CONTROL	1
2	XDFZZ	5965-01-314-7160	57715	H6-NA	.HANDLE,HANDSET	1
3	PAFZZ	6240-00-011-5273	96906	MS15573-1	.LAMP,INCANDESCENT	2
4	XDFZZ	5930-01-317-4082	57715	T0-1-15431/EZ-NA	.SWITCH,ROTARY	1
5	PAFZZ	5930-01-322-1896	57715	QDD-111/110/K11	.PUSH BUTTON	1
6	XDFZZ	6110-01-453-1223	81381	114D323-T20	.TRANSFORMER,POWER	1
7	XDFZZ	5999-01-438-3111	57715	22DILM	.CONTACTOR,INTERUPT	1
8	XDFZZ	6110-01-439-9284	57715	DILOOM-120V60HZ	.CONTACTOR,MAGNETIC	2
9	XDFZZ	5945-01-348-9585	57715	Z00-2.4	.RELAY,THERMAL	1
10	XDFZZ	5945-01-348-9586	57715	Z00-4	.RELAY,THERMAL	1
					End of Figure	

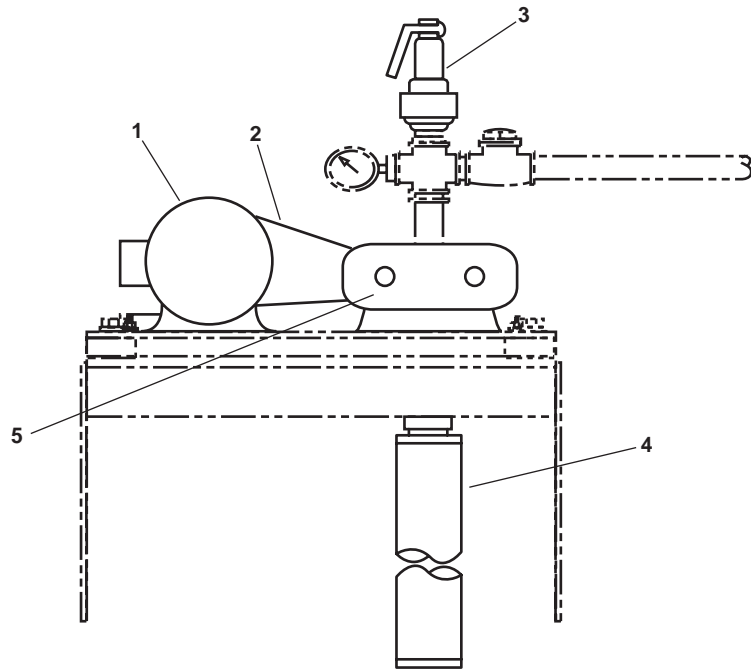

Figure 3. Blower Assembly (Sheet 1 of 2)

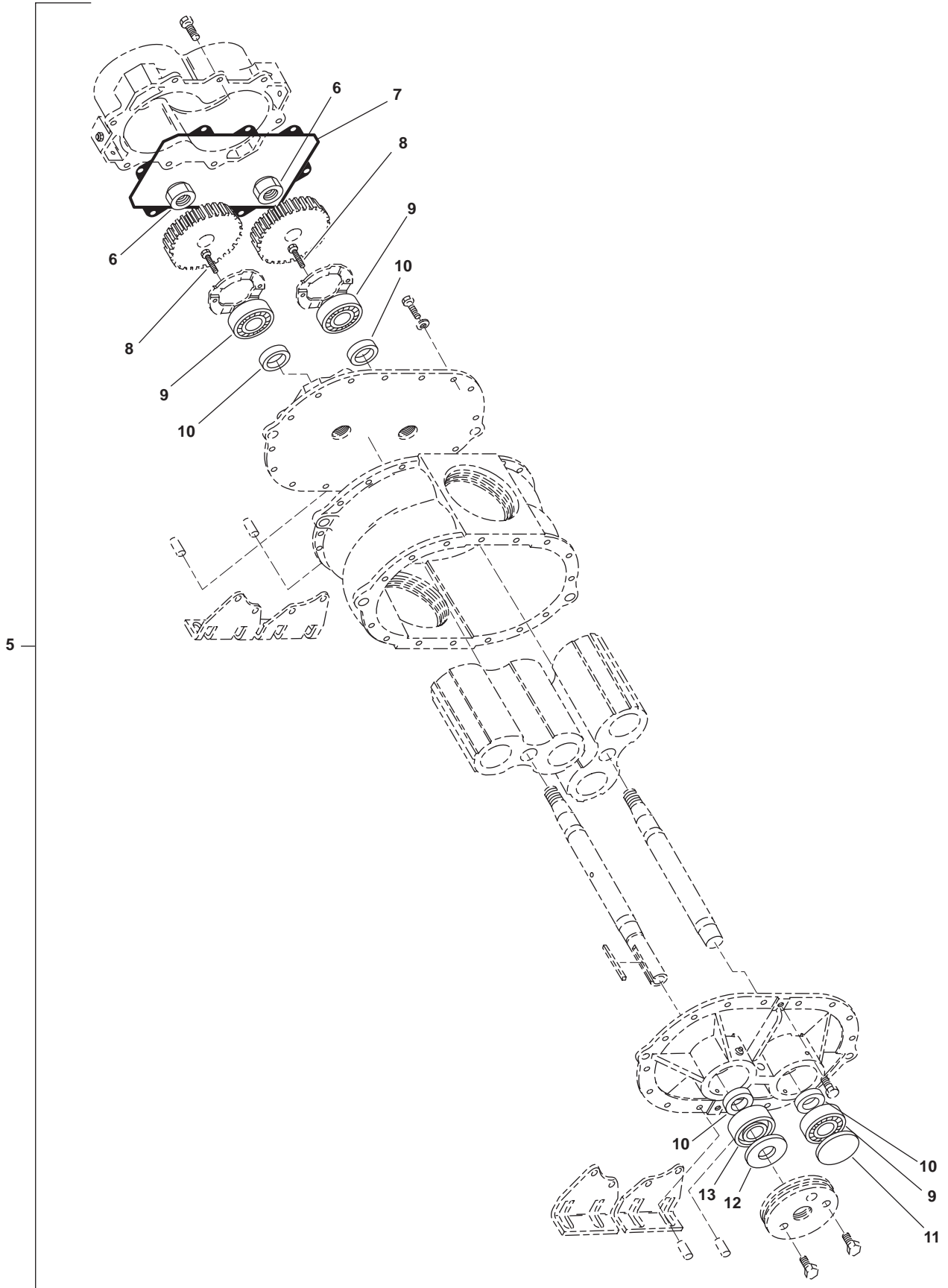

Figure 3. Blower Assembly (Sheet 2 of 2)

(1)	(2)	(3)	(4)	(5)	(6)	(7)
ITEM NO.	SMR CODE	NSN	CAGEC	PART NUMBER	DESCRIPTION AND USABLE ON CODE (UOC)	QTY
					GROUP 0503040201	
					FIG. 3 BLOWER ASSEMBLY	
1	XDOZZ		05472	ECP83580T-4	MOTOR,AC,1HP REPLACED BY P/N JM3545	1
2	PAOZZ	3030-00-529-0346	10855	A33	BELT,DRIVE,BLOWER	1
3	XDOZZ		1X5W8	6182FEM01	VALVE,RELIEF	1
4	XDOZZ		22313	55-115AA	SILENCER	1
5	XDOFF		3E174	URAI 22	BLOWER REPLACED P/N 22 RAI	1
6	KFFZZ		51729	10319022	.NUT,HEX,1/2-20 PART OF KIT P/N 65-102-ORK	2
7	KFFZZ		51729	62791021	.GASKET,GEARBOX PART OF KIT P/N 65-102-ORK	2
8	KFFZZ	5305-01-418-3126	66935	021-17055-000	.SCREW,CAP,HEXAGON H PART OF KIT P/N 65-102-ORK	4
9	KFFZZ	3110-00-516-5289	D2457	6203	.BEARING,BALL,ANNULA PART OF KIT P/N 65-102-ORK	3
10	KFFZZ		51729	10005171	.SEAL,LIP PART OF KIT P/N 65-102-ORK	4
11	KFOZZ		51729	12957001	.PLUG,OPENING PART OF KIT P/N 65-102-ORK	1
12	KFFZZ		51729	12091008	.SEAL,LIP PART OF KIT P/N 65-102-ORK	1
13	KFFZZ		51729	10222032	.BEARING,ROLLER PART OF KIT P/N 65-102-ORK	1
KIT	PAFZZ		3E174	65-102-ORK	.REPAIR KIT,BLOWER	1
					BEARING,BALL,ANNULA (3)	3 - 9
					BEARING,ROLLER (1)	3 - 13
					GASKET,GEARBOX (2)	3 - 7
					NUT,HEX,1/2-20 (2)	3 - 6
					PLUG,OPENING (1)	3 - 11
					SCREW,CAP,HEXAGON H (4)	3 - 8
					SEAL,LIP (1)	3 - 12
					SEAL,LIP (4)	3 - 10
					End of Figure	

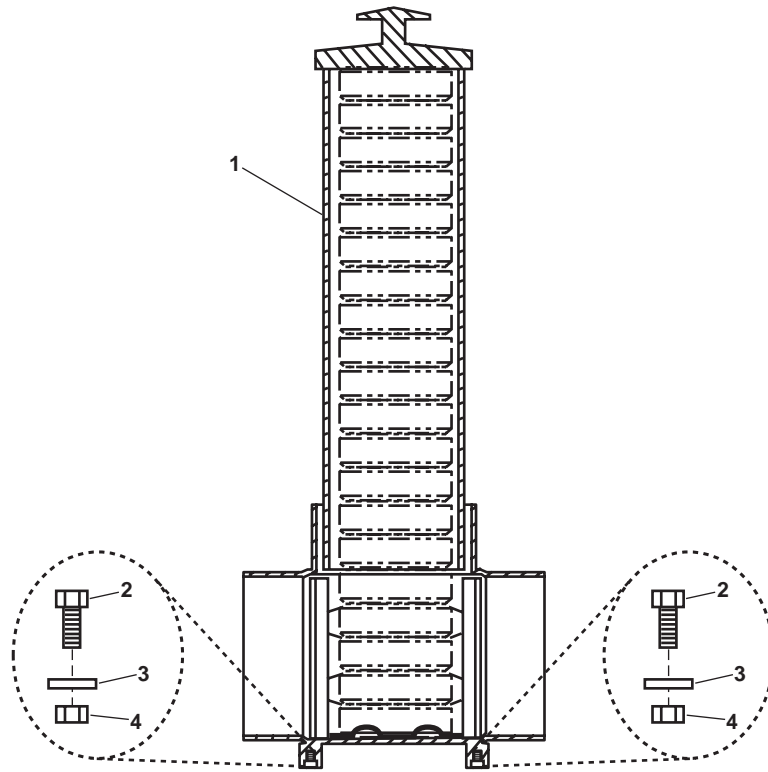

Figure 4. Chlorinator

(1)	(2)	(3)	(4)	(5)	(6)	(7)
ITEM NO.	SMR CODE	NSN	CAGEC	PART NUMBER	DESCRIPTION AND USABLE ON CODE (UOC)	QTY
					GROUP 05030403	
					FIG. 4 CHLORINATOR	
1	XDOZZ		1HG95	LF 500	FEEDER, TABLET REPLACED BY P/N LF-500	1
2	PAOZZ	5305-01-508-6037	39428	93190A583	SCREW, CAP, HEXAGON H	4
3	PAOZZ		39428	90107A030	WASHER, FLAT	4
4	PAOZZ		39428	91850A185	NUT, HEXAGON	4
					End of Figure	

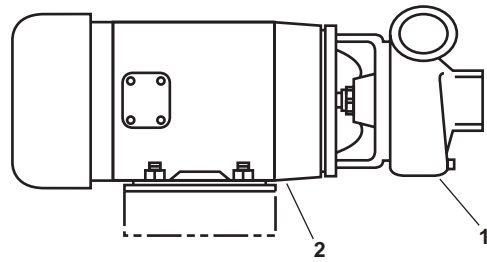

Figure 5. Pump Assembly

(1)	(2)	(3)	(4)	(5)	(6)	(7)
ITEM NO.	SMR CODE	NSN	CAGEC	PART NUMBER	DESCRIPTION AND USABLE ON CODE (UOC)	QTY
					GROUP 0503040401	
					FIG. 5 PUMP ASSEMBLY	
1	XDOFF	4320-01-336-1422	76122	MP-110	PUMP,CENTRIFUGAL	1
2	XDOZZ		05472	CP3583T-4	MOTOR,AC,1.5HP	1
					End of Figure	

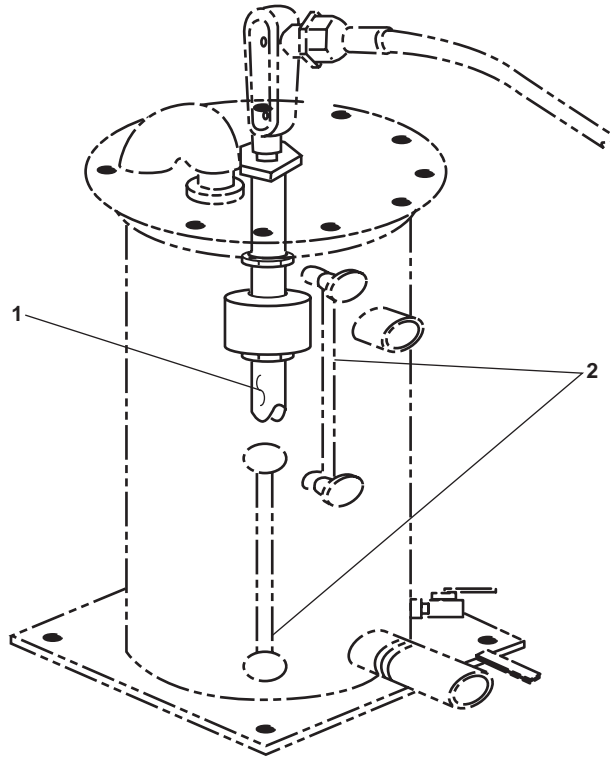

Figure 6. Wet Well

(1)	(2)	(3)	(4)	(5)	(6)	(7)
ITEM NO.	SMR CODE	NSN	CAGEC	PART NUMBER	DESCRIPTION AND USABLE ON CODE (UOC)	QTY
					GROUP 05030405	
					FIG. 6 WET WELL	
1	XDOZZ		78482	901-801-320	SWITCH,FLOAT	1
2	PAOZZ	6680-01-345-3371	72219	20-250	INDICATOR,SIGHT,LIQ SEWAGE TREATMENT SYSTEM	2
					End of Figure	

NATIONAL STOCK NUMBER INDEX

STOCK NUMBER	FIG.	ITEM	STOCK NUMBER	FIG.	ITEM
6240-00-011-5273	2	3	6680-01-345-3371	6	2
6685-00-057-1404	1	4	5945-01-348-9585	2	9
3110-00-516-5289	3	9	5945-01-348-9586	2	10
3030-00-529-0346	3	2	5305-01-418-3126	3	8
5331-01-138-7111	1	2	5999-01-438-3111	2	7
5965-01-314-7160	2	2	6110-01-439-9284	2	8
5930-01-317-4082	2	4	6110-01-453-1223	2	6
5930-01-322-1896	2	5	5305-01-508-6037	4	2
4730-01-325-4141	1	3	5330-01-529-2546	1	7
4320-01-336-1422	5	1			

PART NUMBER INDEX

PART NUMBER	FIG.	ITEM	PART NUMBER	FIG.	ITEM
021-17055-000	3	8	90780A813	1	8
052102.450	1	5	90810A035	1	6
052202.150	1	9	91850A185	4	4
10005171	3	10	93190A583	4	2
10222032	3	13	A33	3	2
10319022	3	6	CP3583T-4	5	2
114D323-T20	2	6	DILOOM-120V60HZ	2	8
12091008	3	12	ECP83580T-4	3	1
12957001	3	11	H6-NA	2	2
146995	1	4	LF 500	4	1
20-250	6	2	MP-110	5	1
22DILM	2	7	MS15573-1	2	3
3WD-78-734-732A	2	1	QDD-111/110/K11	2	5
55-115AA	3	4	ST0720200T1C	1	1
6182FEM01	3	3	ST264-Z-5-B	1	2
6203	3	9	ST264STXX	1	3
62791021	3	7	T0-1-15431/EZ-NA	2	4
65-102-ORK	3	KIT	URAI 22	3	5
761125-025	1	7	Z00-2.4	2	9
901-801-320	6	1	Z00-4	2	10
90107A030	4	3			

END OF WORK PACKAGE

**OPERATOR, UNIT, DIRECT SUPPORT, AND GENERAL SUPPORT MAINTENANCE
MARINE SANITATION DEVICE FOR
INLAND AND COASTAL LARGE TUG (LT)
COMPONENTS OF END ITEM (COEI) AND BASIC ISSUE ITEMS (BII) LISTS**

INTRODUCTION

SCOPE

This work package lists COEI and BII for the marine sanitation device for the Inland and Coastal Large Tug (LT) to help you inventory items for safe and efficient operation of the equipment.

GENERAL

The COEI and BII information is divided into the following lists:

Components of End Item (COEI). This list is for information purposes only and is not authority to requisition replacements. These items are part of the marine sanitation device for the Inland and Coastal Large Tug (LT). As part of the end item, these items must be with the end item whenever it is issued or transferred between property accounts. Items of COEI are removed and separately packaged for transportation or shipment only when necessary. Illustrations are furnished to help you find and identify the items.

Basic Issue Items (BII). These essential items are required to place the marine sanitation device for the Inland and Coastal Large Tug (LT) in operation, operate it, and to do emergency repairs. Although shipped separately packaged, BII must be with the marine sanitation device for the Inland and Coastal Large Tug (LT) during operation and when it is transferred between property accounts. Listing these items is your authority to request/requisition them for replacement based on authorization of the end item by the TOE/MTOE. Illustrations are furnished to help you find and identify the items.

EXPLANATION OF COLUMNS IN THE COEI LIST AND BII LIST

Column (1) Illus Number. Gives you the number of the item illustrated.

Column (2) National Stock Number (NSN). Identifies the stock number of the item to be used for requisitioning purposes.

Column (3) Description, CAGEC, and Part Number. Identifies the Federal item name (in all capital letters) followed by a minimum description when needed. The stowage location of COEI and BII is also included in this column. The last line below the description is the CAGEC (Commercial and Government Entity Code) (in parentheses) and the part number.

Column (4) Usable On Code. When applicable, gives you a code if the item you need is not the same for different models of equipment.

Column (5) Unit of Issue (U/I). Indicates the physical measurement or count of the item as issued per the National Stock Number shown in column (2).

Column (6) Qty Rqr. Indicates the quantity required.

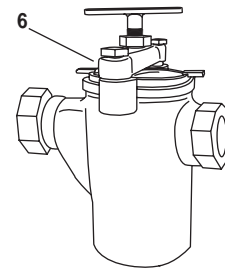
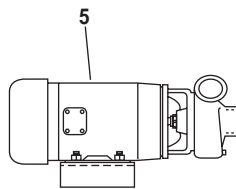
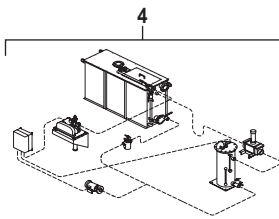
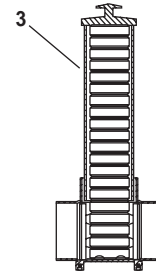
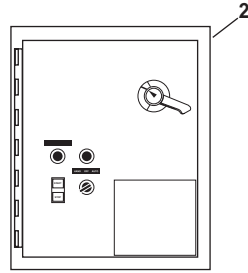
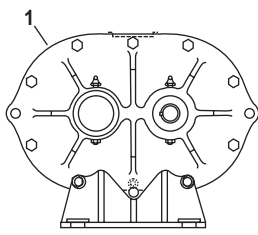

Table 1. Components of End Item List

(1) ILLUS NUMBER	(2) NATIONAL STOCK NUMBER	(3) DESCRIPTION CAGEC, AND PART NUMBER	(4) USABLE ON CODE	(5) U/I	(6) QTY RQR
1	4320-01-336-1422	BLOWER ASSEMBLY (AMS-1) (3E174) URAI-22	128	EA	1
2		CONTROL PANEL (AMS-1) (57715) 3WD-78-734-732A	128	EA	1
3		FEEDER, TABLET (AMS-1) (1HG95) A-200	128	EA	1
4		MARINE SANITATION DEVICE (AMS-1) (78482) M-3	128	EA	1
5		PUMP ASSEMBLY (AMS-1) (76122) MP-110	128	EA	1
6		STRAINER, SIMPLEX (AMS-1) (73124) ST0720200T1C	128	EA	1

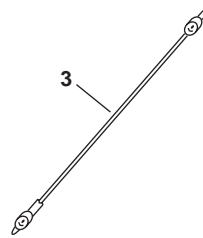
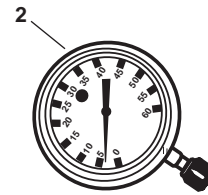
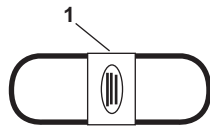

Table 2. On Board Spares List

(1) ILLUS NUMBER	(2) NATIONAL STOCK NUMBER	(3) DESCRIPTION CAGEC, AND PART NUMBER	(4) USABLE ON CODE	(5) U/I	(6) QTY RQR
1	3030-00-529-0346	BELT, DRIVE, BLOWER (bosun's locker) (10855) A33	128	EA	1
2	6685-00-057-1404	GAGE, PRESSURE (vestibule VIDMAR) (61349) 146995	128	EA	1
3	6680-01-345-3371	INDICATOR, SIGHT, LIQUID (bow thruster room) (72219) 20-250	128	EA	1

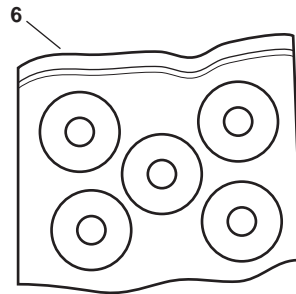
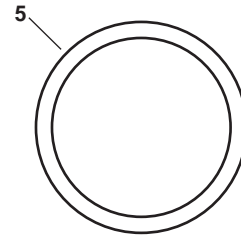
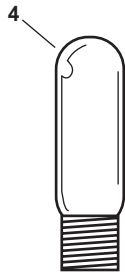

Table 2. On Board Spares List (continued)

(1) ILLUS NUMBER	(2) NATIONAL STOCK NUMBER	(3) DESCRIPTION CAGEC, AND PART NUMBER	(4) USABLE ON CODE	(5) U/I	(6) QTY RQR
4	6240-00-011-5273	LAMP, INCANDESCENT (vestibule VIDMAR) (18876) 10300882	128	EA	2
5	5331-01-138-7111	O RING (vestibule VIDMAR) (73124) ST264-Z-5-B	128	EA	1
6		REPAIR KIT, BLOWER (bow thruster room) (3E174) 65-102-ORK	128	EA	1

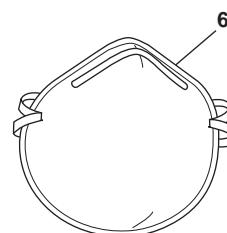
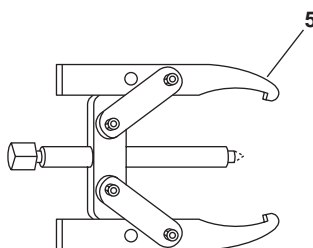
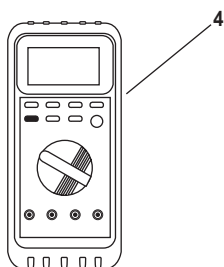
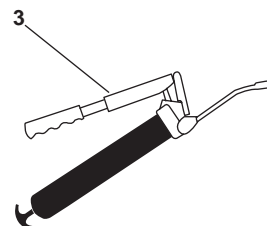
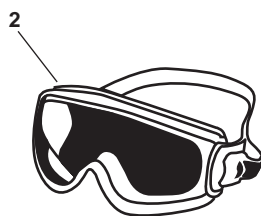

Table 3. Basic Issue Items List

(1) ILLUS NUMBER	(2) NATIONAL STOCK NUMBER	(3) DESCRIPTION CAGEC, AND PART NUMBER	(4) USABLE ON CODE	(5) U/I	(6) QTY RQR
1	8415-01-013-7384	GLOVES, CHEMICAL AND OIL PROTECTIVE (bosun's locker) (81349) MIL-G-87066	128	PR	2
2	4240-00-190-6432	GOGGLES, INDUSTRIAL (machine shop) (80204) ANSI Z87.1-1989	128	PR	2
3	4930-00-223-3389	LUBRICATING GUN, HAND (machine shop) (OFKM1) 7584	128	EA	1
4	6625-01-265-6000	MULTIMETER, AN/PSM45A (DC locker) (89536) 27 W/ACCE	128	EA	1
5	5120-01-349-2706	PULLER, MECHANICAL (machine shop) (51729) 812-977-001	128	EA	1
6	4240-00-868-0203	RESPIRATOR (machine shop) (56434) 122115S	128	EA	1

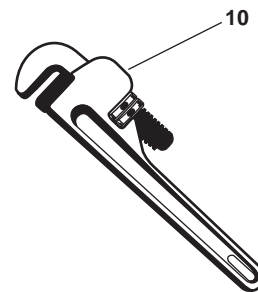
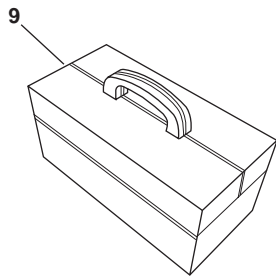
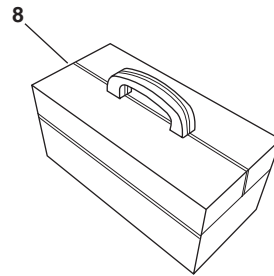
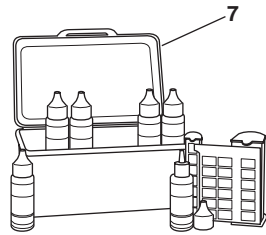

Table 3. Basic Issue Items List (continued)

(1) ILLUS NUMBER	(2) NATIONAL STOCK NUMBER	(3) DESCRIPTION CAGEC, AND PART NUMBER	(4) USABLE ON CODE	(5) U/I	(6) QTY RQR
7	6630-01-531-7670	TEST KIT, SANITIZER (DC locker) (93255) ICQ-260	128	SE	2
8	5180-00-313-3045	TOOL KIT, ELECTRICIAN'S (AMS 2) (50980) SC5180-90-CL-N35	128	EA	1
9	5180-00-629-9783	TOOL KIT, GENERAL MECHANIC'S (machine shop) (50980) SC 5180-90-CL-N55	128	KT	1
10	5120-00-277-1479	WRENCH, PIPE, ADJ, HEAVY DUTY ALUMINUM HANDLE, 18" LONG 1 TO 2" CAP, TYPE 2, CLASS C (tool cage EOS) (80244) 5120-00-277-1479	128	EA	1

END OF WORK PACKAGE

**OPERATOR, UNIT, DIRECT SUPPORT, AND GENERAL SUPPORT MAINTENANCE
MARINE SANITATION DEVICE FOR
INLAND AND COASTAL LARGE TUG (LT)
EXPENDABLE AND DURABLE ITEMS LIST**

INTRODUCTION

SCOPE

This work package lists expendable and durable items that you will need to operate and maintain the marine sanitation device for the Inland and Coastal Large Tug (LT). This list is for information only and is not authority to requisition the listed items. These items are authorized to you by CTA 50-970, Expendable/Durable Items (Except Medical, Class V Repair Parts, and Heraldic Items), or CTA 8-100, Army Medical Department Expendable/Durable Items.

EXPLANATION OF COLUMNS IN THE EXPENDABLE/DURABLE ITEMS LIST

Column (1) Item Number. This number is assigned to the entry in the list and is referenced in the narrative instructions to identify the item (e.g., "Use brake fluid (item 5, WP 0098 00).").

Column (2) Level. This column identifies the lowest level of maintenance that requires the listed item (include as applicable: C = Operator/Crew, O = Unit, F = Direct Support, H = General Support, D = Depot).

Column (3) National Stock Number (NSN). This is the NSN assigned to the item, which you can use to requisition it.

Column (4) Item Name, Description, Commercial and Government Entity Code (CAGEC), and Part Number (P/N). This column provides the other information you need to identify the item.

Column (5) Unit of Issue (U/I). Indicates the physical measurement or count of the item as issued per the National Stock Number shown in column (3).

Table 1. Expendable and Durable Items List

(1) ITEM NUMBER	(2) LEVEL	(3) NATIONAL STOCK NUMBER (NSN)	(4) ITEM NAME, DESCRIPTION, CAGEC, AND PART NUMBER	(5) U/I
1	C	6850-00-281-1985	DRY CLEANING SOLVENT (02978) PS661	GL
2	O	9150-00-180-6381	GREASE, GENERAL PURPOSE (81349) MIL-PRF-24139	CN
3	F	9150-00-186-6699	LUBRICATING OIL, ENGINE (81349) MIL-L-46152	QT
4	C	7920-00-205-1711	RAG, WIPING, 50LB BALE (80244) 7920-00-205-1711	BE
5	F	8030-01-025-1692	SEALING COMPOUND, LOCTITE 242 (81349) MIL-S-46163	BT
6	C	6850-00-177-5094	SILICONE COMPOUND, 2 OZ PER TUBE (71984) DC4-2OZ	TU
7	O		TAG, DANGER (USED FOR LOCKOUT/TAGOUT) (3HPE6) 0116-LF-115-4300	BX
8	C	8030-00-889-3535	TAPE, ANTISEIZING, 1/2 IN X 260 IN (96214) 417043-2	EA

END OF WORK PACKAGE

**OPERATOR, UNIT, DIRECT SUPPORT, AND GENERAL SUPPORT MAINTENANCE
MARINE SANITATION DEVICE FOR
INLAND AND COASTAL LARGE TUG (LT)
GLOSSARY**

Aeration	The act of charging a liquid with a gas, making it bubble.
AMS	Auxiliary Machinery Space.
Baffle	A device used to deflect, check, or regulate flow. In the MSD, baffles direct the flow of water through the tank.
Corrosion	A substance, such as rust, resulting from the act or process of dissolving or wearing away materials.
Effluent	A flow-through or overboard discharge of water mixed with sewage. In the MSD, the effluent is the fluid flowing from the media tank.
Impeller	The blade of a rotor. In the MSD, the impellers of the blower create air flow, aerating the media tank.
Lobe	A rounded projection that is part of the impeller.
Media	Microorganisms present in sewage growing on the surface area of the Marine Sanitation Device.
Sheave	A wheel or disk with a grooved rim, especially one used as a pulley. In the MSD the sheaves hold the blower belt transferring mechanical motion from the motor to the blower.
Wedge	A block of wood used to prevent the sliding, rolling, or spinning of an object.
Wet Well	A retention tank sized to provide adequate contact time for chlorine to disinfect water during peak flow periods.

END OF WORK PACKAGE

<u>Subject</u>	<u>WP Sequence No.-Page No.</u>
Chlorinator	
Feed Tube	
Adjust	0013 00-2
Clean	0014 00-3
Replace	0024 00-1
Tablets, Replenish	0014 00-4
Clean	
Chlorinator Feed Tube	0014 00-3
Media Tank	0014 00-7
Wet Well Inlet Strainer	0014 00-10
COEI List	0038 00-2
Components of End Item List	0038 00-2
Contactors	
Interrupt, Replace	0028 00-9
Magnetic, Replace	0028 00-7
Control Panel, MSD, Controls and Indicators	0004 00-1
Controller, Repair	0015 00-1
	0028 00-1
Controls and Indicators, Operator, Description and Use	0004 00-1
Corrosion Prevention and Control	0001 00-1
CPC	0001 00-1
D	
Description and Use of Operator Controls and Indicators	0004 00-1
Destruction of Army Materiel to Prevent Enemy Use	0001 00-2
Differences Between Models	0002 00-2
Discharge Sampling	0013 00-1
Discharge to Overboard, Water Closet	0006 00-4
E	
EDIL	0039 00-1
EIR	0001 00-1
Emergency Procedures	0006 00-1
Equipment	
Capabilities	0002 00-1
Characteristics	0002 00-1
Data	0002 00-2
Description and Data	0002 00-1
Features	0002 00-1
Expendable and Durable Items List	0039 00-1
F	
Failure, Blower	0006 00-4
Features, Equipment	0002 00-1
Flanged Gate Valve, Replace	0027 00-3
Float Switch Replacement	0030 00-1
Forms, Maintenance	0001 00-1
G	
General Information	0001 00-1
Glossary	Glossary-1

<u>Subject</u>	<u>WP Sequence No.-Page No.</u>
H	
Handle Replacement	0028 00-4
How to Use This Manual	iii
I	
Interrupt Contactor Replacement	0028 00-9
L	
Lamp Replacement	0015 00-1
List of Abbreviations/Acronyms	0001 00-2
Location and Description of Major Components	0002 00-1
Low Pressure Air Pressure Gauge Replacement	0020 00-1
Lubricate Blower Bearings	0017 00-1
M	
MAC	0035 00-1
MAC Introduction	0034 00-1
Magnetic Contactor Replacement	0028 00-7
Maintenance Allocation Chart	0035 00-1
Maintenance Allocation Chart Introduction	0034 00-1
Maintenance	
Forms	0001 00-1
Records	0001 00-1
Reports	0001 00-1
Major Components, Location and Description	0002 00-1
Marine Sanitation Device	
Adjust	0013 00-1
Control Panel, Controls and Indicators	0004 00-1
Repair	0020 00-1
	0027 00-1
	0032 00-1
Service	0014 00-1
Media Tank	
Air Scour	0014 00-5
Clean	0014 00-7
Pump Out	0014 00-5
Motor, Blower Assembly, Replace	0023 00-1
MSD	
Adjust	0013 00-1
Control Panel, Controls and Indicators	0004 00-1
Service	0014 00-1
Valves AMS 1, Controls and Indicators	0004 00-5
Valves Engine Room Forward, Controls and Indicators	0004 00-7
O	
OBSL	0038 00-3
ODS	0001 00-1
Oil, Blower, Change	0017 00-3
On Board Spares List	0038 00-3

<u>Subject</u>	<u>WP Sequence No.-Page No.</u>
Operation	
Theory	0003 00-1
Under Unusual Conditions	0006 00-1
Under Usual Conditions	0005 00-1
Operator	
Controls and Indicators, Description and Use	0004 00-1
PMCS	0012 00-1
Troubleshooting Procedures	0008 00-1
Overboard Discharge, Water Closet	0006 00-4
Ozone Depleting Substances	0001 00-1

P

Parallel Sheave Alignment	0016 00-4
PMCS	
Introduction	0011 00-1
Operator	0012 00-1
Preliminary	
Adjustments	0010 00-1
Checks	0010 00-1
Servicing of Equipment	0010 00-1
Preparation for	
Shipment	0001 00-2
Storage	0010 00-1
Storage	0001 00-2
Storage	0010 00-1
Preventive Maintenance Checks and Services Introduction	0011 00-1
Procedures	
Emergency	0006 00-1
Operator Troubleshooting	0008 00-1
Troubleshooting, Use of	0007 00-1
Unit Troubleshooting	0009 00-1
Pump Assembly	
Repair	0026 00-1
Replace	0025 00-1
Pump Out Media Tank	0014 00-5
Pushbutton Switch Replacement	0028 00-5

Q

Quality of Material	0001 00-4
---------------------------	-----------

R

Records, Maintenance	0001 00-1
References	0033 00-1
Relay, Thermal, Replace	0028 00-6
Relief Valve, Blower Discharge Pressure, Replace	0022 00-1
Repair	
Blower	0022 00-1
Blower Assembly	0018 00-1
Blower Assembly, Blower	0029 00-1
Controller	0015 00-1
Controller	0028 00-1
Marine Sanitation Device	0020 00-1
Marine Sanitation Device	0027 00-1
Pump Assembly	0026 00-1
Wet Well	0019 00-1
Wet Well	0030 00-1

<u>Subject</u>	<u>WP Sequence No.-Page No.</u>
Repair Parts and Special Tools List.....	0037 00-1
Introduction	0036 00-1
Replace	
Belt	0016 00-1
Blower Assembly Motor	0023 00-1
Blower Discharge Pressure Relief Valve	0022 00-1
Chlorinator	0024 00-1
Float Switch	0030 00-1
Handle	0028 00-4
Interrupt Contactor	0028 00-9
Lamp	0015 00-1
Low Pressure Air Pressure Gauge	0020 00-1
Magnetic Contactor	0028 00-7
Pump Assembly	0025 00-1
Pushbutton Switch	0028 00-5
Rotary Switch	0028 00-3
Sight Glass	0019 00-1
Silencer	0018 00-1
Strainer	0032 00-1
Thermal Relay	0028 00-6
Threaded Gate Valve	0027 00-1
Transformer	0028 00-7
Wet Well	0031 00-1
Replenish Chlorinator Tablets	0014 00-4
Reporting Equipment Improvement Recommendations	0001 00-1
Reports, Maintenance	0001 00-1
Requirements, Shelter	0010 00-1
Residual Chlorine Test	0014 00-1
Rotary Switch Replacement.....	0028 00-3
RPSTL	0037 00-1
RPSTL Introduction	0036 00-1
S	
Sampling, Discharge	0013 00-1
Scope	0001 00-1
Security Measures for Electronic Data	0005 00-1
	0006 00-1
Service	
Blower Assembly	0017 00-1
Marine Sanitation Device	0014 00-1
Preliminary	0010 00-1
Upon Receipt	0010 00-1
Sewage Discharge Pump Controller, Controls and Indicators	0004 00-3
Sewage Holding Tank	
to Shore Connection	0005 00-6
From Water Closet	0006 00-2
Shelter Requirements	0010 00-1
Shipment, Preparation	0001 00-2
	0010 00-1
Shore Connection, Sewage Holding Tank	0005 00-6
Shutdown, System	0005 00-10
Sight Glass Replacement	0019 00-1
Silencer Replacement	0018 00-1

<u>Subject</u>	<u>WP Sequence No.-Page No.</u>
Startup, System	0005 00-1
Storage, Preparation	0001 00-2
.....	0010 00-1
Strainer	
Replace	0032 00-1
Wet Well Inlet, Clean	0014 00-10
Switch	
Float, Replace	0030 00-1
Pushbutton, Replace	0028 00-5
System	
Shutdown	0005 00-10
Startup	0005 00-1
T	
Table of Contents	i
Test, Residual Chlorine	0014 00-1
Theory of Operation	0003 00-1
Thermal Relay Replacement	0028 00-6
Threaded Gate Valve Replacement	0027 00-1
Transformer Replacement	0028 00-7
Troubleshooting	
Index	0007 00-1
How to Use	0007 00-1
Procedures	
Operator	0008 00-1
Unit	0009 00-1
Use of	0007 00-1
U	
Unit Troubleshooting Procedures	0009 00-1
Unusual Environment/Weather	0006 00-1
Use of	
Troubleshooting Index	0007 00-1
Troubleshooting Procedures	0007 00-1
V	
Valve, Flanged Gate, Replace	0027 00-3
Valve, Threaded Gate, Replace	0027 00-1
W	
Warning Summary	a
Warranty Information	0001 00-2
Water Closet	
Discharge to Overboard	0006 00-4
to Sewage Holding Tank	0006 00-2
Wet Well	
Inlet Strainer, Clean	0014 00-10
Repair	0019 00-1
.....	0030 00-1
Replace	0031 00-1

By Order of the Secretary of the Army:

Official:

SANDRA R. RILEY
*Administrative Assistant to the
Secretary of the Army*

0529217

PETER J. SCHOOMAKER
*General, United States Army
Chief of Staff*

DISTRIBUTION: To be distributed in accordance with the initial distribution requirements for IDN: 255634, requirements for TM 55-1925-284-14&P.

RECOMMENDED CHANGES TO PUBLICATIONS AND BLANK FORMS For use of this form, see AR 25-30; the proponent agency is OAASA	Use Part II (<i>reverse</i>) for Repair Parts and Special Tool Lists (RPSTL) and Supply Catalogs/Supply Manuals (SC/SM).	DATE
---	--	------

TO: (<i>Forward to proponent of publication or form</i>) (<i>Include ZIP Code</i>) AMSTA-LC-LMPP / TECH PUBS 1 Rock Island Arsenal Rock Island, IL 61299-7630	FROM: (<i>Activity and location</i>) (<i>Include ZIP Code</i>)
---	---

PART I - ALL PUBLICATIONS (EXCEPT RPSTL AND SC/SM) AND BLANK FORMS

PUBLICATION/FORM NUMBER TM 55-1925-284-14&P	DATE 30 November 2005	TITLE Operator, Unit, Direct Support, and General Support Maintenance Manual Including Repair Parts and Special Tools List for Marine Sanitation Device Inland and Coastal Large Tug (LT) NSN 1925-01-509-7013 (EIC XAG)
--	--------------------------	---

ITEM	PAGE	PARA- GRAPH	LINE	FIGURE NO.	TABLE	RECOMMENDED CHANGES AND REASON
------	------	----------------	------	---------------	-------	--------------------------------

SAMPLE

<i>* Reference to line numbers within the paragraph or subparagraph.</i>		
TYPED NAME, GRADE OR TITLE	TELEPHONE EXCHANGE/AUTOVON, PLUS EXTENSION	SIGNATURE

TO: <i>(Forward direct to addressee listed in publication)</i> AMSTA-LC-LMPP / TECH PUBS 1 Rock Island Arsenal Rock Island, IL 61299-7630	FROM: <i>(Activity and location) (Include ZIP Code)</i>	DATE
---	--	-------------

PART II - REPAIR PARTS AND SPECIAL TOOL LISTS AND SUPPLY CATALOGS/SUPPLY MANUALS

PUBLICATION NUMBER TM 55-1925-284-14&P	DATE 30 November 2005	TITLE Operator, Unit, Direct Support, and General Support Maintenance Manual Including Repair Parts and Special Tools List for Marine Sanitation Device Inland and Coastal Large Tug (LT) NSN 1925-01-509-7013 (EIC XAG)
--	---------------------------------	--

PAGE NO.	COLM NO.	LINE NO.	NATIONAL STOCK NUMBER	REFERENCE NO.	FIGURE NO.	ITEM NO.	TOTAL NO. OF MAJOR ITEMS SUPPORTED	RECOMMENDED ACTION
<h1>SAMPLE</h1>								

PART III - REMARKS *(Any general remarks or recommendations, or suggestions for improvement of publications and blank forms. Additional blank sheets may be used if more space is needed.)*

TYPED NAME, GRADE OR TITLE	TELEPHONE EXCHANGE/AUTOVON, PLUS EXTENSION	SIGNATURE
-----------------------------------	---	------------------

RECOMMENDED CHANGES TO PUBLICATIONS AND BLANK FORMS For use of this form, see AR 25-30; the proponent agency is OAASA	Use Part II (<i>reverse</i>) for Repair Parts and Special Tool Lists (RPSTL) and Supply Catalogs/Supply Manuals (SC/SM).	DATE
---	--	------

TO: (<i>Forward to proponent of publication or form</i>) (<i>Include ZIP Code</i>) AMSTA-LC-LMPP / TECH PUBS, TACOM-RI 1 Rock Island Arsenal Rock Island, IL 61299-7630	FROM: (<i>Activity and location</i>) (<i>Include ZIP Code</i>)
---	---

PART I - ALL PUBLICATIONS (EXCEPT RPSTL AND SC/SM) AND BLANK FORMS

PUBLICATION/FORM NUMBER TM 55-1925-284-14&P	DATE 30 November 2005	TITLE Operator, Unit, Direct Support, and General Support Maintenance Manual Including Repair Parts and Special Tools List for Marine Sanitation Device Inland and Coastal Large Tug (LT) NSN 1925-01-509-7013 (EIC XAG)
--	--------------------------	---

ITEM	PAGE	PARA- GRAPH	LINE	FIGURE NO.	TABLE	RECOMMENDED CHANGES AND REASON

** Reference to line numbers within the paragraph or subparagraph.*

TYPED NAME, GRADE OR TITLE	TELEPHONE EXCHANGE/AUTOVON, PLUS EXTENSION	SIGNATURE
----------------------------	---	-----------

TO: <i>(Forward direct to addressee listed in publication)</i> AMSTA-LC-LMPP / TECH PUBS, TACOM-RI 1 Rock Island Arsenal Rock Island, IL 61299-7630	FROM: <i>(Activity and location) (Include ZIP Code)</i>	DATE
---	--	-------------

PART II - REPAIR PARTS AND SPECIAL TOOL LISTS AND SUPPLY CATALOGS/SUPPLY MANUALS

PUBLICATION NUMBER TM 55-1925-284-14&P	DATE 30 November 2005	TITLE Operator, Unit, Direct Support, and General Support Maintenance Manual Including Repair Parts and Special Tools List for Marine Sanitation Device Inland and Coastal Large Tug (LT) NSN 1925-01-509-7013 (EIC XAG)
--	---------------------------------	--

PAGE NO.	COLM NO.	LINE NO.	NATIONAL STOCK NUMBER	REFERENCE NO.	FIGURE NO.	ITEM NO.	TOTAL NO. OF MAJOR ITEMS SUPPORTED	RECOMMENDED ACTION

PART III - REMARKS *(Any general remarks or recommendations, or suggestions for improvement of publications and blank forms. Additional blank sheets may be used if more space is needed.)*

--

TYPED NAME, GRADE OR TITLE	TELEPHONE EXCHANGE/AUTOVON, PLUS EXTENSION	SIGNATURE

TO: <i>(Forward direct to addressee listed in publication)</i> AMSTA-LC-LMPP / TECH PUBS, TACOM-RI 1 Rock Island Arsenal Rock Island, IL 61299-7630	FROM: <i>(Activity and location) (Include ZIP Code)</i>	DATE
---	--	-------------

PART II - REPAIR PARTS AND SPECIAL TOOL LISTS AND SUPPLY CATALOGS/SUPPLY MANUALS

PUBLICATION NUMBER TM 55-1925-284-14&P	DATE 30 November 2005	TITLE Operator, Unit, Direct Support, and General Support Maintenance Manual Including Repair Parts and Special Tools List for Marine Sanitation Device Inland and Coastal Large Tug (LT) NSN 1925-01-509-7013 (EIC XAG)
--	---------------------------------	--

PAGE NO.	COLM NO.	LINE NO.	NATIONAL STOCK NUMBER	REFERENCE NO.	FIGURE NO.	ITEM NO.	TOTAL NO. OF MAJOR ITEMS SUPPORTED	RECOMMENDED ACTION

PART III - REMARKS *(Any general remarks or recommendations, or suggestions for improvement of publications and blank forms. Additional blank sheets may be used if more space is needed.)*

TYPED NAME, GRADE OR TITLE	TELEPHONE EXCHANGE/AUTOVON, PLUS EXTENSION	SIGNATURE
----------------------------	--	-----------

TO: <i>(Forward direct to addressee listed in publication)</i> AMSTA-LC-LMPP / TECH PUBS, TACOM-RI 1 Rock Island Arsenal Rock Island, IL 61299-7630	FROM: <i>(Activity and location) (Include ZIP Code)</i>	DATE
---	--	-------------

PART II - REPAIR PARTS AND SPECIAL TOOL LISTS AND SUPPLY CATALOGS/SUPPLY MANUALS

PUBLICATION NUMBER TM 55-1925-284-14&P	DATE 30 November 2005	TITLE Operator, Unit, Direct Support, and General Support Maintenance Manual Including Repair Parts and Special Tools List for Marine Sanitation Device Inland and Coastal Large Tug (LT) NSN 1925-01-509-7013 (EIC XAG)
--	---------------------------------	--

PAGE NO.	COLM NO.	LINE NO.	NATIONAL STOCK NUMBER	REFERENCE NO.	FIGURE NO.	ITEM NO.	TOTAL NO. OF MAJOR ITEMS SUPPORTED	RECOMMENDED ACTION

PART III - REMARKS *(Any general remarks or recommendations, or suggestions for improvement of publications and blank forms. Additional blank sheets may be used if more space is needed.)*

TYPED NAME, GRADE OR TITLE	TELEPHONE EXCHANGE/AUTOVON, PLUS EXTENSION	SIGNATURE

Metric Conversion Factors

Mc x F = Cf		
Measurement to be Converted (Mc)	Factor (F)	Converted Measurement (Cf)
Meters (m)	x 39.37	= Inches (in.)
Meters (m)	x 3.281	= Feet (ft)
Meters (m)	x 1.094	= Yards (yd)
Inches (in.)	x 25.40	= Millimeters (mm)
Inches (in.)	x 2.54	= Centimeters (cm)
Inches (in.)	x 0.0254	= Meters (m)
Inches (in.)	x 25400	= Micrometers (μm)
Feet (ft)	x 0.305	= Meters (m)
Square feet (ft ²)	x 0.093	= Square meters (m ²)
Foot-Pounds	x 1.35582	= Newton meters (N m)
Newton meters (N m)	x 0.73756	= Foot Pounds
Yards (yd)	x 0.914	= Meters (m)
Square yards (yd ²)	x 0.836	= Square meters (m ²)
Square Inches (in ²)	x 6.452	= Square Centimeters (cm ²)
Cubic Inches (in ³)	x 16.39	= Cubic Centimeters (cm ³)
Cubic Centimeters (cm ³)	x 0.061	= Cubic Inches (in ³)
Cubic Feet (ft ³)	x 0.028	= Cubic Meters (cm ³)
Gallons (gal)	x 3.785	= Liters (L)
Liters (L)	x 0.2642	= Gallons (gal)
Kilometers (km)	x 0.5397	= Nautical miles (nmi)
Meters (m)	x 0.0005397	= Nautical miles (nmi)
Nautical miles (nmi)	x 1.853	= Kilometers (km)
Fluid Ounces (oz)	x 29.574	= Milliliters (mL)
Pounds (lb)	x 0.4536	= Kilograms (kg)
Kilograms (kg)	x 2.2046	= Pounds (lb)
Kilopascals (kPa)	x 0.145	= Pounds (lb) per Square Inch (psi)
Pounds per Square Inch (psi)	x 6.895	= Kilopascals (kPa)
Degrees Centigrade (°C)	(°C x 1.8) + 32	= Degrees Fahrenheit (°F)
Degrees Fahrenheit (°F)	(°F-32) ÷ 1.8	= Degrees Centigrade (°C)
Bar	x 14.5	= Pounds per Square Inch (psi)
Pounds per Square Inch (psi)	x 0.06894	= Bar
Horsepower (hp)	x 0.746	= Kilowatt (kW)
Kilowatt (kW)	x 1.341	= Horsepower (hp)

